

# Reinforcement 1

**Jake Jyrkama, P.E.**  
*Rinker Materials*



**REINFORCEMENT**  
**HOW IT'S MADE**



## QUALITY SCHOOL



### Purpose of Reinforcement

- Concrete properties
  - Strong in compression
  - Weak in tension
- Reinforcement supplies strength to withstand tensile and shear forces experienced by concrete





# QUALITY SCHOOL



## Compressive Forces on Concrete

COMPRESSIVE

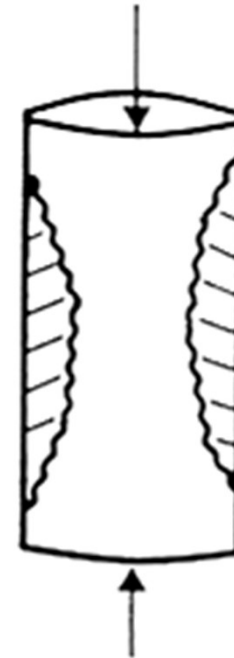

Concrete can withstand compression





# QUALITY SCHOOL



## Concrete Under Compression

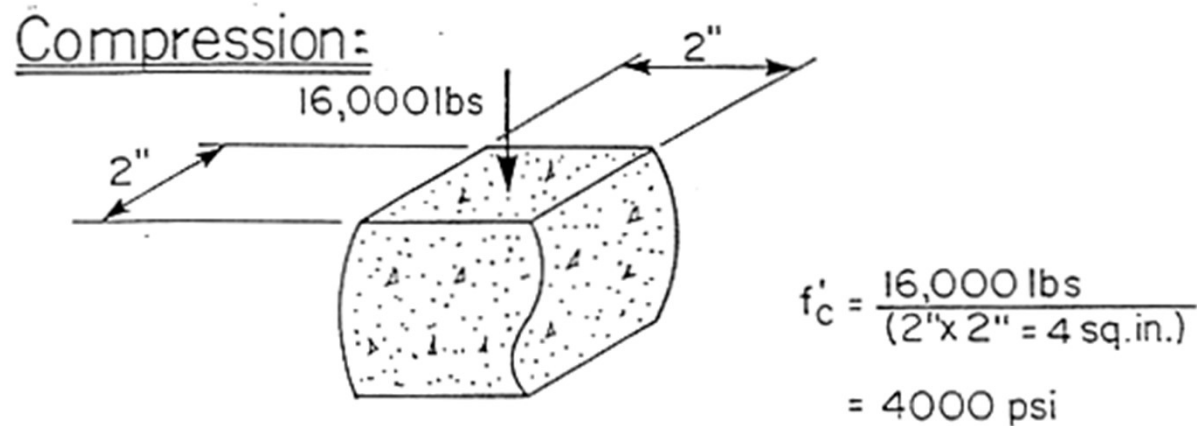

This 2" X 2" cube of concrete withstands a 4000 psi compressive force





# QUALITY SCHOOL



## Tensile Forces on Concrete

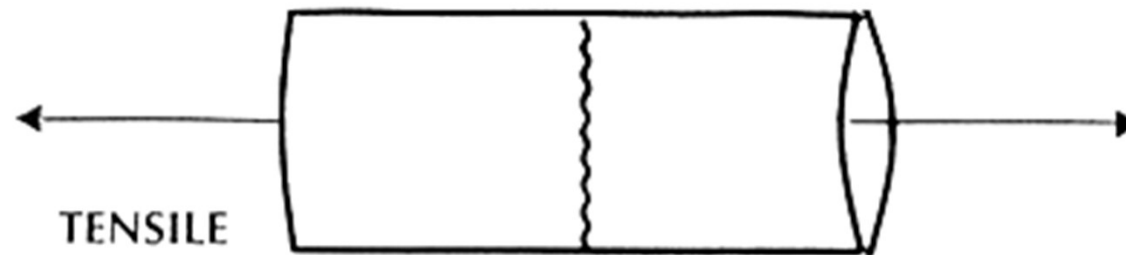

Without reinforcement, concrete will fail in tension





## Concrete Under Tension

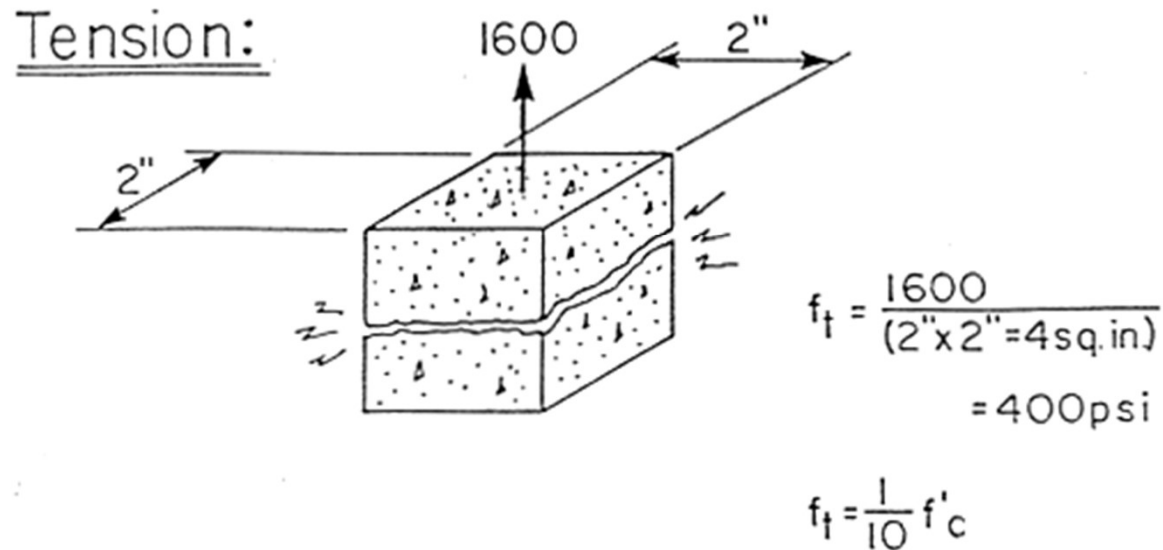

The same 2" X 2" cube of concrete fails under a 400 psi *tensile* force





# QUALITY SCHOOL



## Non-reinforced Concrete Behavior

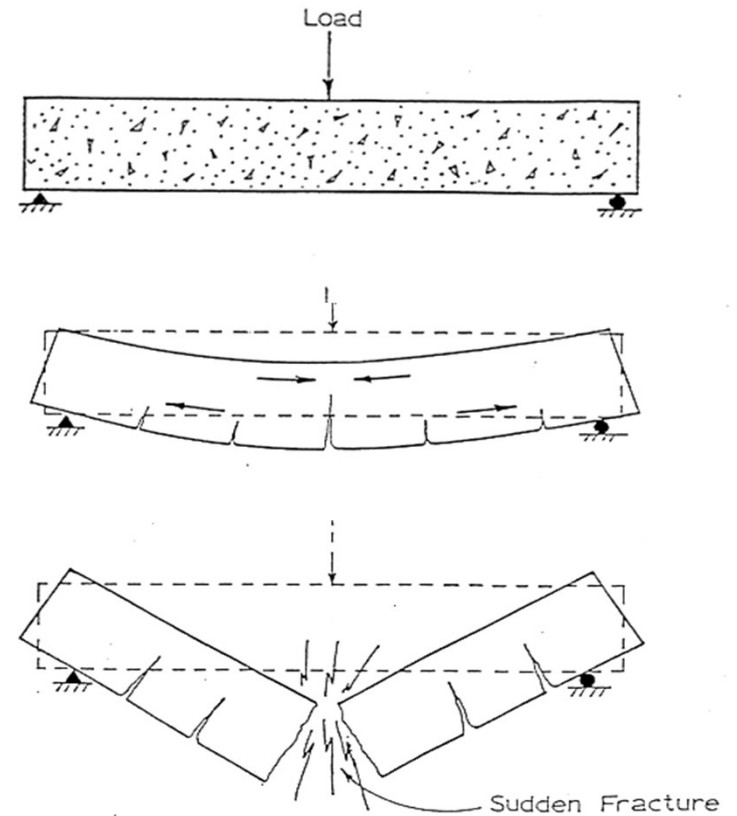



## Flexural Forces on Concrete

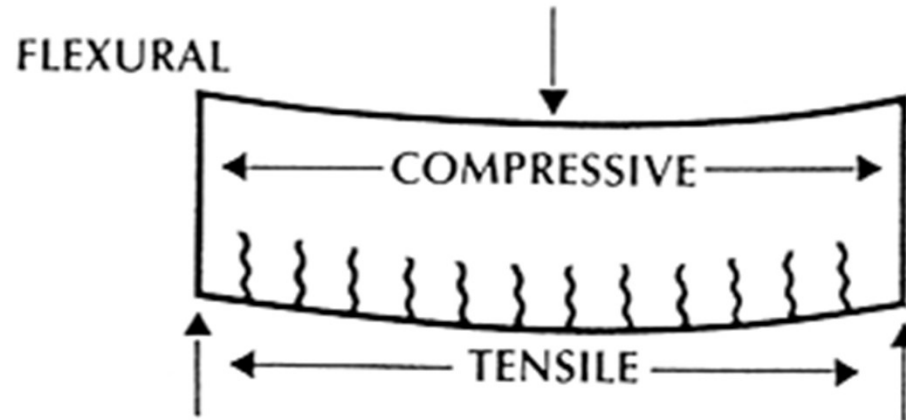

Without reinforcement, the bottom side will fail in tension



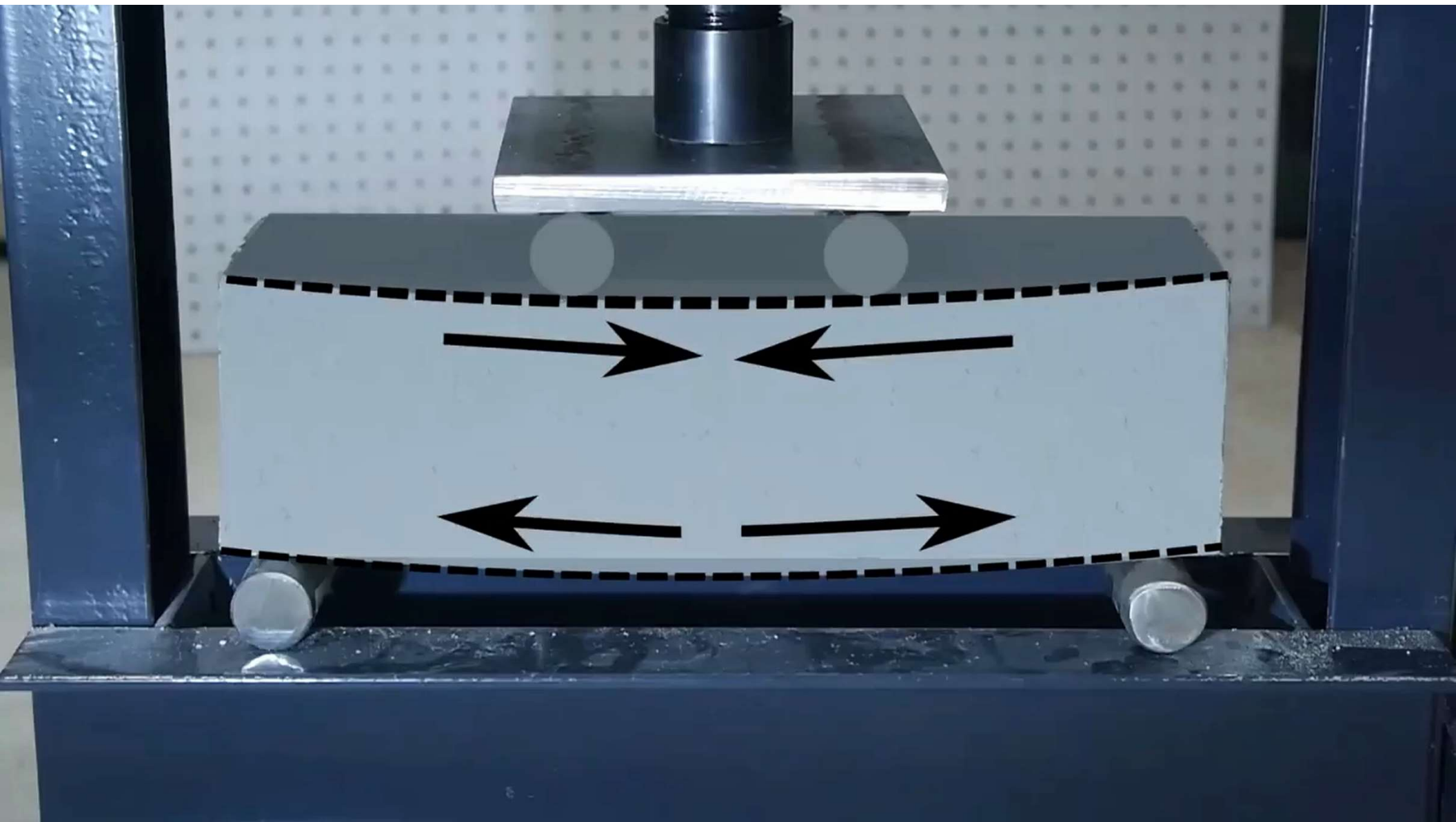



# QUALITY SCHOOL



## Reinforced Concrete Behavior

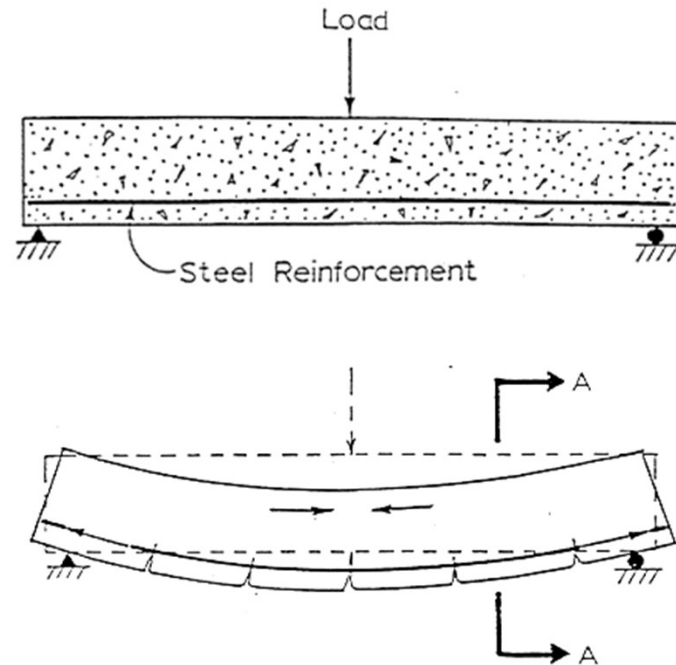





# QUALITY SCHOOL



## Concrete Behavior Under Shear

Vertical Shear

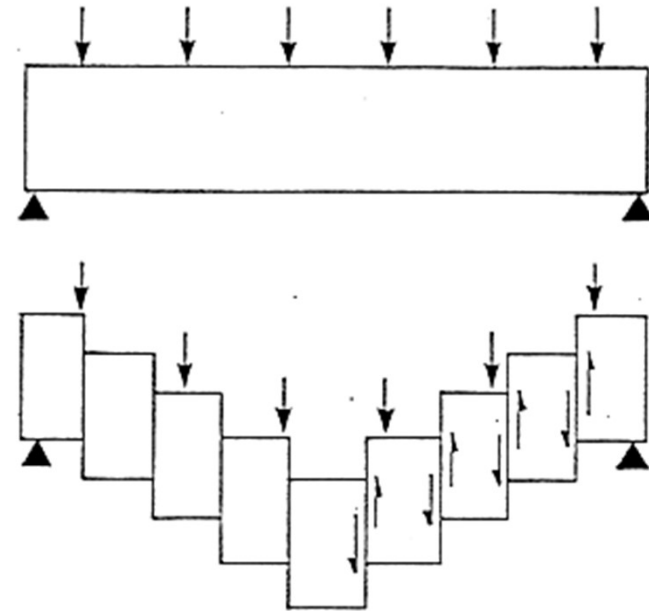



## Concrete Behavior Under Shear

Horizontal shear

shear reinforcement

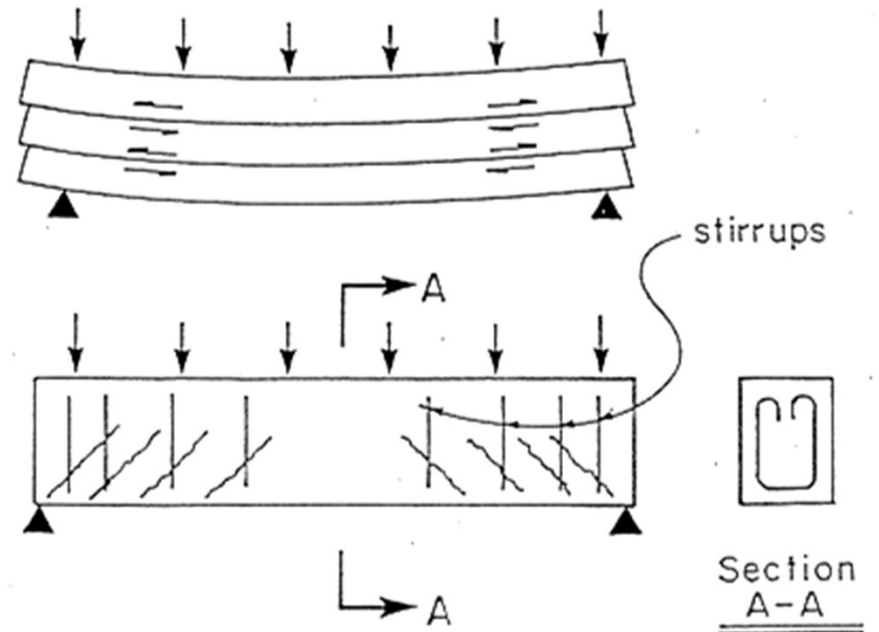



## Effectiveness of Placement

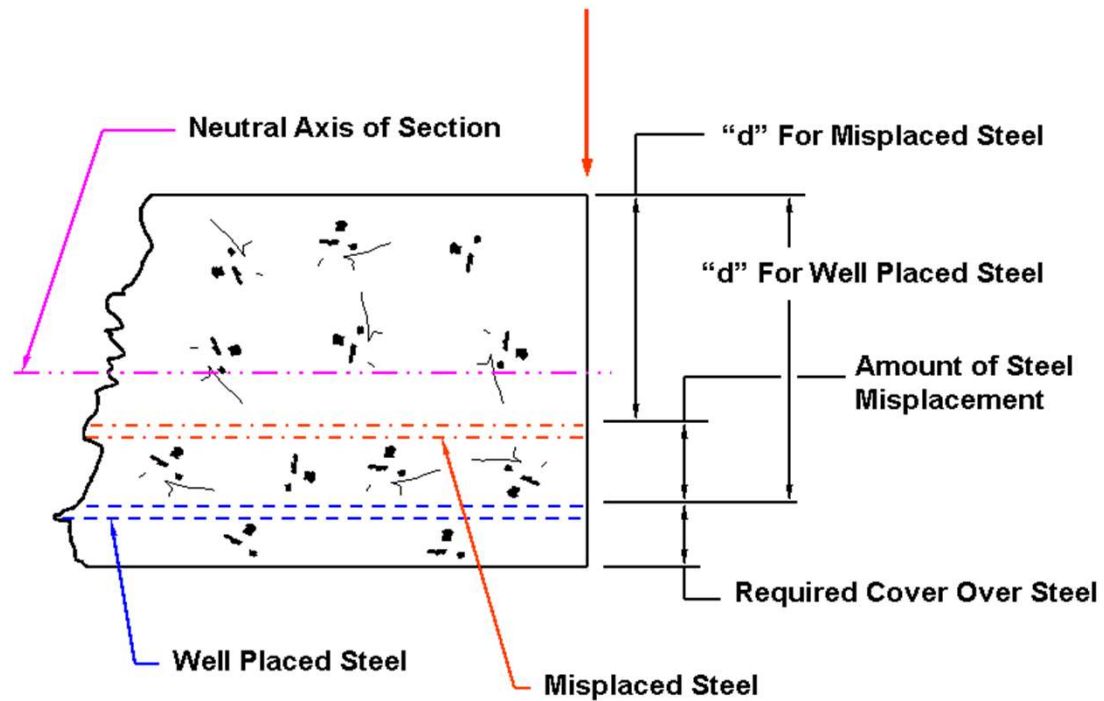



# QUALITY SCHOOL



## 0.01" Crack in Pipe

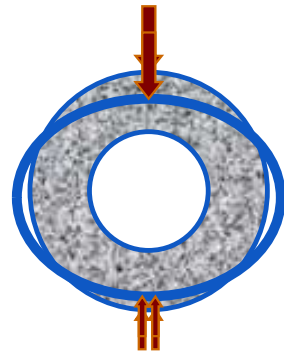

DEFLECTION UNDER TEST CONDITION

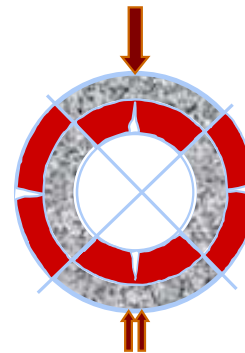

STRESS ZONES UNDER TEST CONDITION



TENSION



COMPRESSION





# QUALITY SCHOOL

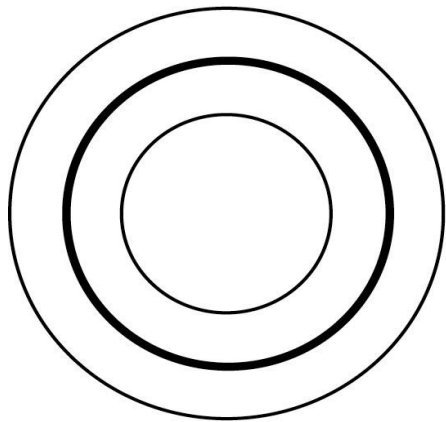

Single Circular Cage

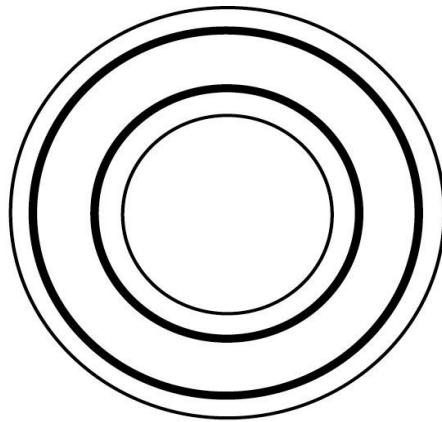

Double Circular Cages

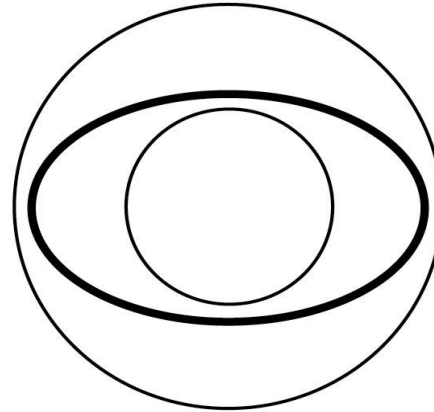

Single Elliptical Cage

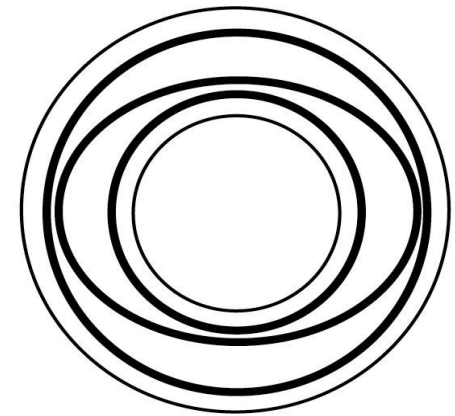

Combination Elliptical and Circular Cages

**Figure 2.1.** Four Cage Configurations Commonly Employed in the Manufacture of Reinforced Concrete Pipe.





# QUALITY SCHOOL



## EXAMPLE: Ø36" X 4" WALL

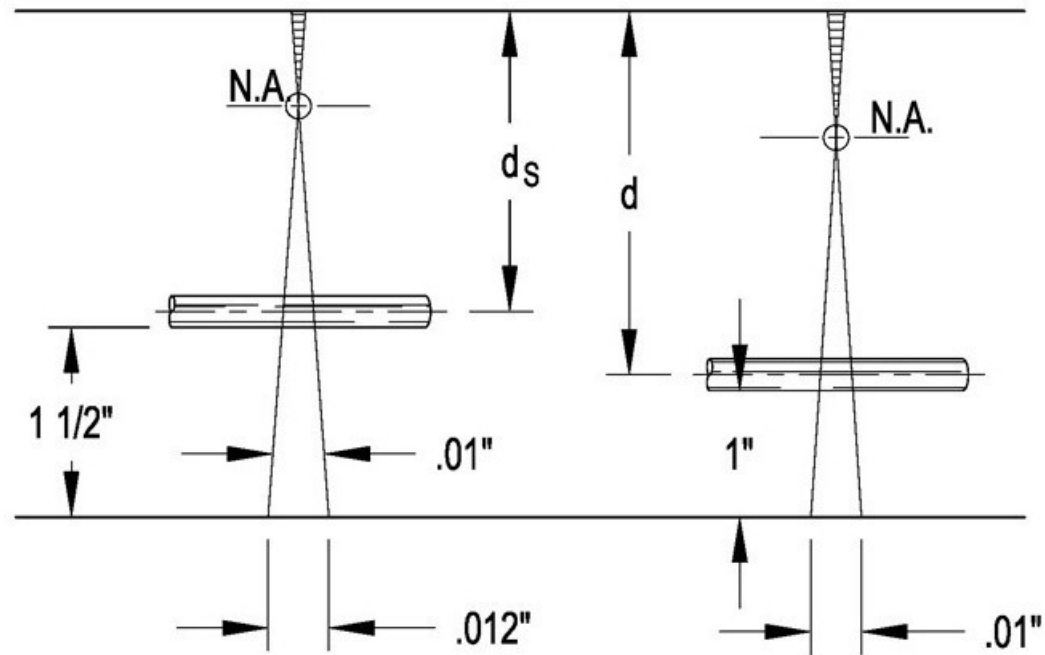

MOVING STEEL INTO WALL TO 1 1/2" VS 1" COVER **INCREASED STEEL BY 47%** DUE TO SHORTER  $d$  AND DUE TO CRACKING GEOMETRY





# QUALITY SCHOOL



## Ø36" X 4" WALL

AS d = RESISTANCE TO CRACK WIDTH

d. MIN. = 147 %

d. NOM. = 100%

d. MAX. = 77%

**D- LOAD WOULD VARY BY 34% IF WE USED THE ALLOWED CAGE POSITION TOLERANCE FROM C76**

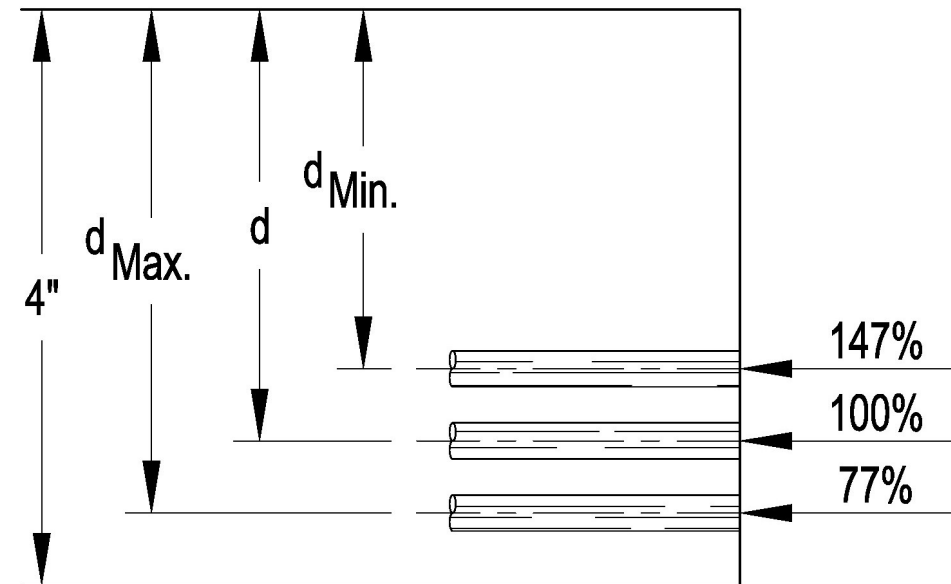



# QUALITY SCHOOL



# Box Culvert





## Steel Nomenclature

As<sub>1</sub> = Sidewall outside face

As<sub>2</sub> = Top slab inside face

As<sub>3</sub> = Bottom slab inside face

As<sub>4</sub> = Sidewall inside face

As<sub>5</sub> = Top slab inside distribution steel

As<sub>6</sub> = Top slab outside distribution steel

As<sub>7</sub> = Top slab outside face

As<sub>8</sub> = Bottom slab outside face

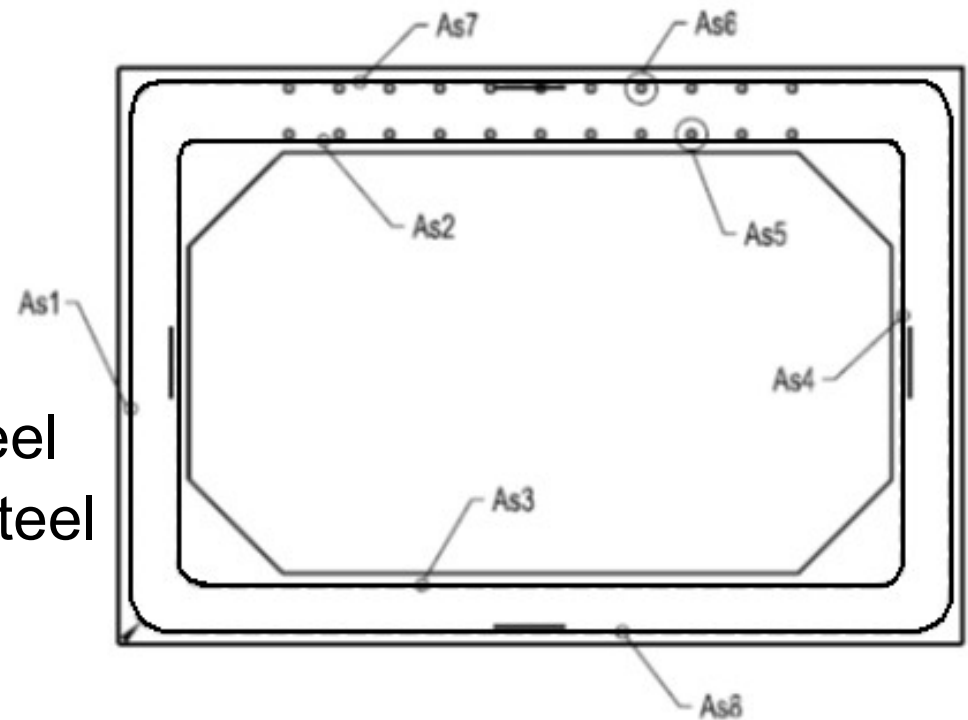





## QUALITY SCHOOL



### Effects of Increased Steel Cover

- Reduced 0.01” strength
- Reduced shear strength
- Reduced radial tension strength
- Increased cost
- Waste of steel





## QUALITY SCHOOL



### Effectiveness of Placement

- It is critical to have correct steel placement for both pipe and box culverts





# QUALITY SCHOOL



## Reinforcement Type and Identification





## QUALITY SCHOOL



### Reinforcement Types

- Reinforcing bars
- Reinforcing wire
- Bar mats and welded wire reinforcement
- Zinc or epoxy coated reinforcement
- Prestressing and post tensioning
- ❖ All types must meet “Buy America” Requirements for federally funded projects





## QUALITY SCHOOL



### Reinforcing Bars

- Conform to specifications
  - ASTM A615 (New Billet)
  - ASTM A616 (Rail)
  - ASTM A617 (Axle)
  - ASTM A706 (Weldable)
- Other bars may be used if permitted by design
- Mill certificates required for each shipment





# QUALITY SCHOOL



## Grade 40 & 50 Rebar

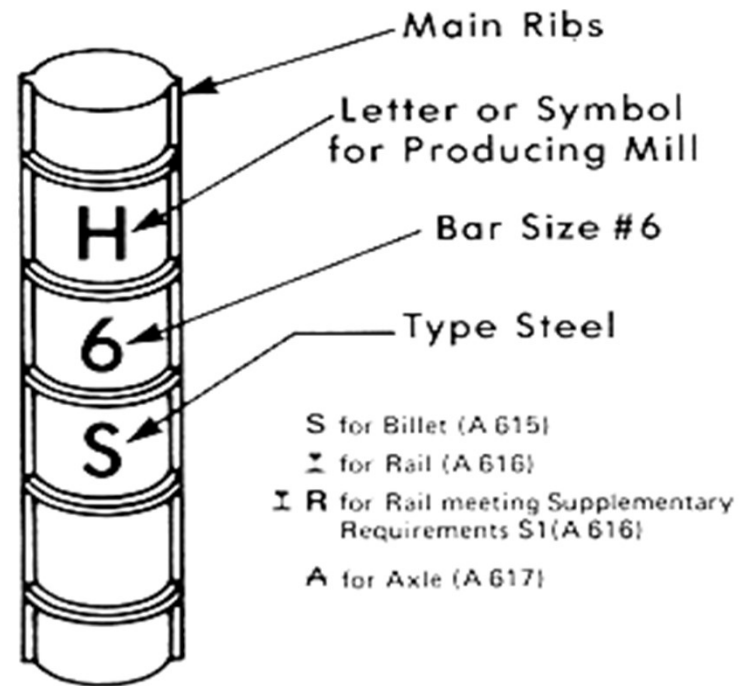



# QUALITY SCHOOL



## Grade 60 & A706 Rebar

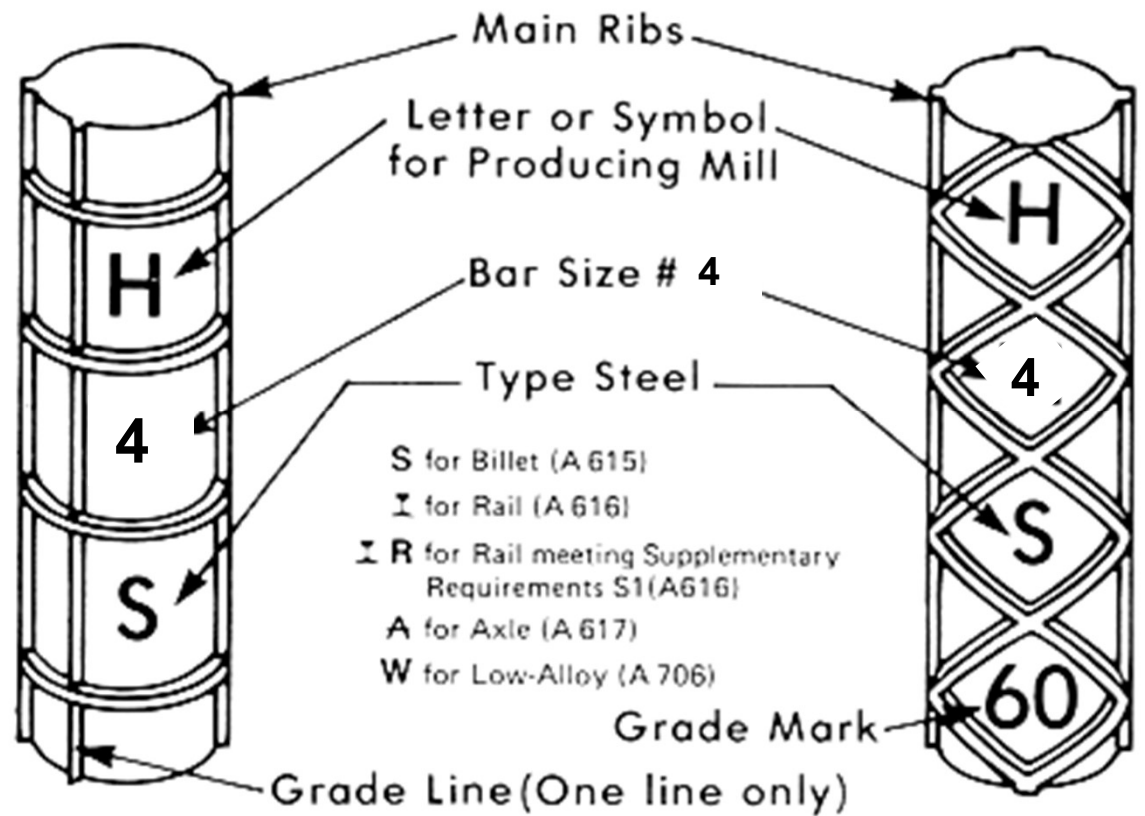



# QUALITY SCHOOL



## Steel Area Using Different Combinations of Bar Sizes and Spacing

<u>Spacing</u>	<u>#4</u>	<u>#5</u>	<u>#6</u>	<u>#7</u>	<u>#8</u>	<u>#9</u>	<u>#10</u>	<u>#11</u>
2 in.	1.20	1.86	2.64					
3 in.	0.80	1.24	1.76	2.40	3.16	4.00		
4 in.	0.60	0.93	1.32	1.80	2.37	3.00	3.81	4.68
5 in.	0.48	0.74	1.06	1.44	1.90	2.40	3.05	3.74
6 in.	0.40	0.62	0.88	1.20	1.58	2.00	2.54	3.12
7 in.	0.34	0.53	0.75	1.03	1.35	1.71	2.18	2.67
8 in.	0.30	0.47	0.66	0.90	1.19	1.50	1.91	2.34
9 in.	0.27	0.41	0.59	0.80	1.05	1.33	1.69	2.08
10 in.	0.24	0.37	0.53	0.72	0.95	1.20	1.52	1.87
11 in.	0.22	0.34	0.48	0.65	0.86	1.09	1.39	1.70
12 in.	0.20	0.31	0.44	0.60	0.79	1.00	1.27	1.56
13 in.	0.18	0.29	0.41	0.55	0.73	0.92	1.17	1.44
14 in.	0.17	0.27	0.38	0.51	0.68	0.86	1.09	1.34
15 in.	0.16	0.25	0.35	0.48	0.63	0.80	1.02	1.25
16 in.	0.15	0.23	0.33	0.45	0.59	0.75	0.95	1.17
17 in.	0.14	0.22	0.31	0.42	0.56	0.71	0.90	1.10
18 in.	0.13	0.21	0.29	0.40	0.53	0.67	0.85	1.04





## QUALITY SCHOOL



### Reinforcing Wire (Plain and Deformed)

- Conform to (except prestressing wire)
  - ASTM A1064
- Other wire may be used if permitted by design
- Mill certificates for each shipment





## QUALITY SCHOOL



### Bar Mats and WWR (Plain and deformed)

- Conform to
  - ASTM A1064
- Mill certificates for each shipment
- Applications of rolled vs. straight



# How Welded Wire Reinforcement is Made



# QUALITY SCHOOL



## Welded Wire Reinforcement

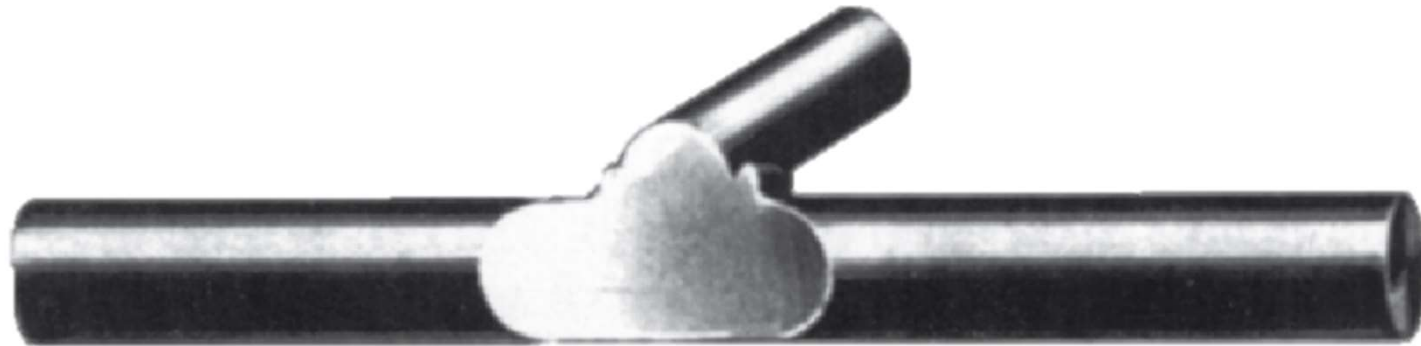



# QUALITY SCHOOL



## Welded Wire Reinforcement

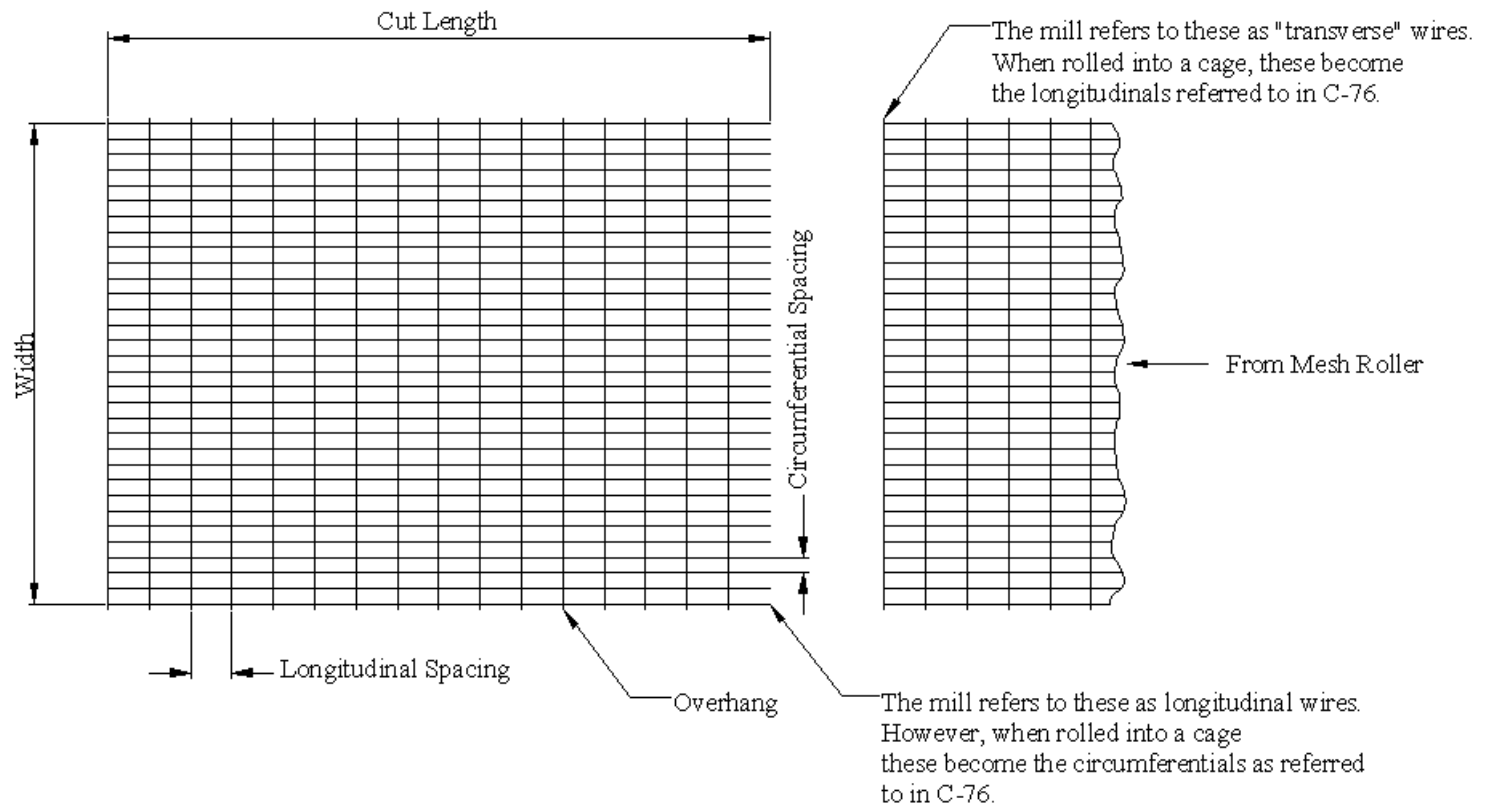



# QUALITY SCHOOL



## Cage Basics

Spacing between pipe longitudinals

Area of one circumferential wire (.025 sq. in.)

Length of roll

3x8 W2.5xW2.0 93"x600' 1/2x1/2

Overhangs

Spacing between pipe circumferentials

Area of one longitudinal wire (.02 sq. in.)

Width of mesh – from top to bottom circumferential

W = Plain/Smooth, D = Deformed





Concrete Reinforcements, Inc.  
Houston, TX

Order #:

[REDACTED] - [REDACTED] - [REDACTED]

[REDACTED] - [REDACTED]

[REDACTED]

**2XV - D6.5/D4.5 X D6**

**7X5X8- AS2/3- C1577 - 2'-15'FILL  
AS2/=0.330, AS4=0.195**

[REDACTED]

Sheets Per Bundle: **32**

Sheet Weight (lbs): **138.40**

Welder Operator:

Quality Review:

ASTM-A1064-18A



## QUALITY SCHOOL



### Wire Size and Designation

- No. = Cross sectional Area in Hundredths of Sq. In.
- Thus
  - W5 = 0.05 Sq. In.
  - W5.5 = 0.055 Sq. In.
  - D10 = 0.10 Sq. In.





## QUALITY SCHOOL



### Cage Basics

- Given 3x8 W2.5xW2.0
- **What is the steel area per foot of pipe?**

$$A = 0.025 \times \frac{12}{3} = 0.10 \text{ in}^2/\text{ft}$$





## QUALITY SCHOOL



### Structural Integrity Depends on

- **Grade** of the reinforcing steel
- **Size** of the reinforcing steel
- **Spacing** of the reinforcing steel
- **Positioning** of the reinforcing steel



# Thank You

Jake Jyrkama, P.E.

[Jaakko.Jyrkama@RinkerPipe.com](mailto:Jaakko.Jyrkama@RinkerPipe.com)

