



Box Culvert Reinforcement Production Practices

Packerhead Manufactured Pipe Reinforcement

ACPA 2026 Pipe School



Bill Washabaugh

www.concrete-pipe.org



Northern Concrete Pipe, Inc. Quality Training

Reinforcing Cage Production

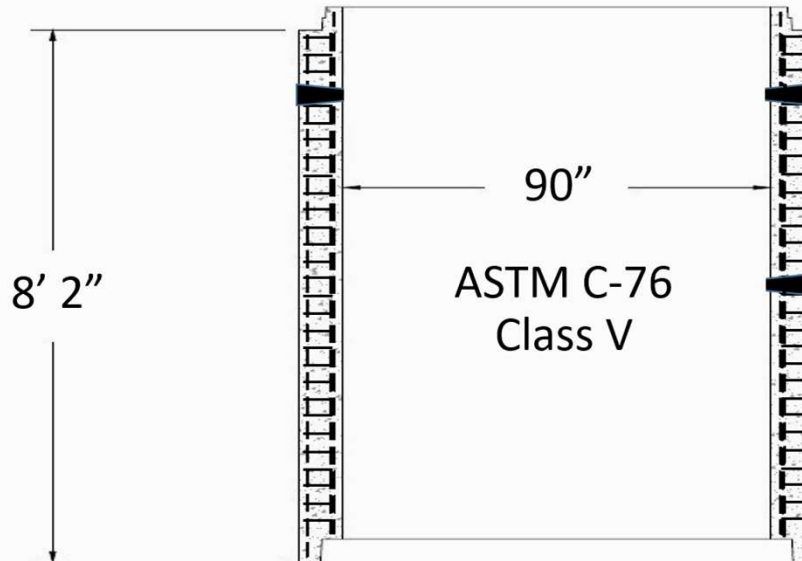



- Blue Star in Right Top Corner:
- It is intended that this Power Point Presentation can be used as a Handbook in your Precast Plant. Due the combining of both a Pipe Type and a Box Culvert Class, there are some obvious duplications of common points. Most of these have been starred so we don't spend much time reviewing them twice, but we need them there when you go back to reference just one of the product types.
- The first section will talk about Common Basics of BOTH Products.



Introduction

- All of the products that the ACPA represents that have reinforcing in them, have minimum standards of some type like those we are about to review. These are too numerous to list here. All are listed in the ACPA's **SELECTED ASTM STANDARDS BOOK**. Please be certain that you maintain the current manuals as they are revised annually.
- All ASTM specification notes are in BLUE. We will not have time to go through all of them but this will provide you with good future reference information when you need it.
- These BLUE Specifications; Jake covered many of them in Session 1.
- **Note: All ASTM references are to the 2020 Versions**



Disclaimers:

- The information presented in this class is based on theory, research and ASTM Specifications as practiced by Northern Concrete Pipe, and a few other ACPA member Companies who were willing to share their cage making experiences.
- Please, DO NOT modify your company's current practices without evaluating and evaluating by testing, these conclusions with the proper person who has the authority to modify those practices in your Plant or Company.
- If you are not a PE, please do not practice that expertise and please do not make assumptions on changes.



- There are many charts and tables included in this presentation for your consideration that there will not be time to spend reviewing the whole content of.
- Feel free to call me anytime for clarification.
- Please Visit the ACPA website to be able to review these and all previous product reinforcing classes.



- Questions; as you think of them, please feel free to stop me at any time to get your questions answered as we go.
- It is more important to cover what you want to talk about than getting through this presentation.
- There is a great deal of experience in this room today that we can all learn from by your asking questions **or making suggestions**.
- There are certainly more ways than those shown in this presentation to accomplish our consistent quality goals and requirements.



- This class will be focused on making quality reinforcing cages. Regardless of the product type or shape, most of the general reinforcement **ASTM** requirements are typical for all shapes of products represented by the ACPA.
- We want you to have a good understanding of the general requirements for reinforcing our products and to then know when you need to reference the ASTM Specifications.



- We will follow the **ASTM C76, ASTM C1433 and C1577** requirements in this evaluation. Most of the requirements in C1786 for non-monolithic box production are the same as we are going to review today.
- It is my opinion; that understanding the **specifications for cage making** is more important than knowing how to make the cage....you need to know **what is not right!**



- Today, we are not going to just focus on the **ASTM** specifications; we are going to focus on what we in production have to do to make certain the reinforcing designed for our products, **functions as it was designed to do.**
- We will include the **ASTM** specs enough to show how they fit. That study must further be done on your own.... **Continuously** as these specifications are modified and updated Annually.



- Additionally, we will talk about how **ASTM PERMISSIBLE VARIATIONS** are incorporated in these standards.
- Then, we will try to indicate how these standards are verified by the ACPA QCast Certification program.
- We also intend to squeeze in some of the Safety Practices while making cages. **Safety is most important.** The Pipe School Safety classes will help maintain that focus for us.



Handouts and Education Aids:

- There is a list of **ACPA Associate Member Preferred Suppliers in the Appendix** of this presentation. Please support those suppliers who support our industry! They have plenty of contacts to get you further information on the products they have available to help us all accomplish what we are reviewing today.
- There may also be **Handouts in the back** of the room from those Associates who chose to supply us with them.
- Thank you to those Associates who helped us assemble this class information!



Plant Practices; **Training Your Crew:**

In the Appendix of this Power Point Presentation is a very useful SHORT VERSION about many of the topics we will discuss today. I included it because I think it is a very good training tool for educating **your** Box Culvert Wire Cage Production Crew. It was shared with us by the good people at what used to be **Cretex**.....Thanks.



- Why do we continue to have classes on **REINFORCEMENT** at virtually every Pipe School?



- There is nothing more important to the performance of the precast products that we all make, than **the structure that we build** with the correct reinforcing that we build into our products.
- Reinforcement needs to be properly **configured**, properly **fabricated**, properly **installed** and properly **positioned** to insure the best quality production of Precast Concrete Box Culverts!
- Virtually all sewer systems are now being video or visually inspected after installation. Doing the reinforcing right, improves the **performance, looks** and **profitability** from YOUR PRIDE in doing the best you can.
- With today's inspection methods, YOUR product is representing the **entire reinforced concrete precast industry** against the alternative pipe, box culvert and bridge products.



- I did a class on reinforcing a few years ago at the Pipe School and on the class evaluation form, one student wrote that what I said **was too technical for his responsibilities.**
- I have to tell you that person would not last in our Plants.
- This process is too important to the success of **your Company,** and **our industry,** for it to be considered as being left to be anyone else's responsibility!



What Makes A Good Cage?

- Right Steel Areas (Circumferential & Longitudinal)
- Correct Cage Dimensions
- Proper Laps &/or Good Welds
- Proper Spacers & Chairs
- Meet required ASTM/DOT Specifications
- Spacers fit & Cover is Correct
- Provides for Safe Handling of the Product
- Product Casting Operator can fill the form at the maximum speed as it minimizes bridging



- All of the Pipe and Box Culvert Products we make that are represented by the ACPA are also able to be certified by the **ACPA Q Cast Plant Certification** program.
- **QCast Certification requires:**
 - Detailed design information, including **cage dimensional tolerances and minimum laps**, shall be available in the reinforcing fabrication area for cages/reinforcement being fabricated.
 - Steel reinforcing shall comply with the requirements of the **project specifications**.



- Per **QCast**; Plants shall maintain, on file, the following **reinforcing** design information:
 - Typical Pre-Pour Visual Inspections of:
 - Reinforcing Placement
 - Handling Holes or Devices
 - Reinforcing Cover
 - Reinforcing Style
 - Reinforcing Dimensions
 - Steel Area - Specified
 - Reinforcing Location in the Product Wall
 - Reinforcing Lap Length (welded or tied)
 - Fiber Reinforcing - if used
 - Embedded steel location and connections
 - Shear Steel
 - Haunch Reinforcement



- Per **QCast**; Plants shall maintain, on file, the following **reinforcing** design information:

Dimensional Inspection that must be measured and recorded:

- Cage Dimensions
- Horizontal Wire Spacing
- Horizontal Wire Diameter
- Horizontal Area of the Wire
- Vertical Wire Spacing
- Vertical Wire Diameter
- Vertical Area of the Wire
- Length of the Cage
- Reinforcing Lap Length (welded or tied)
- Fiber Reinforcement - if used
- Shear Steel



Additionally per **QCast**; Plants shall maintain, on file, the following reinforcing design information:

Pre-Pour Visual Inspection:

- Reinforcing Placement
- Handling Holes/Lifting Devices
- Tie-Pin Holes
- Spacer Size and Location
- Check the Welds
- Reinforcing Location in the Form (Especially Quadrant Mats and Elliptical Steel)



Q Cast also states:

- Maintain reports documenting the inspection of the **reinforcing used** for each specific design produced. At a minimum, measure and document **one cage per size and class** at the start of each production run, one cage at the start of each new shift after that, and one cage if any component or setting is changed.
- Please refer to the Q Cast Reinforcing Inspection Tables towards the back of this presentation.

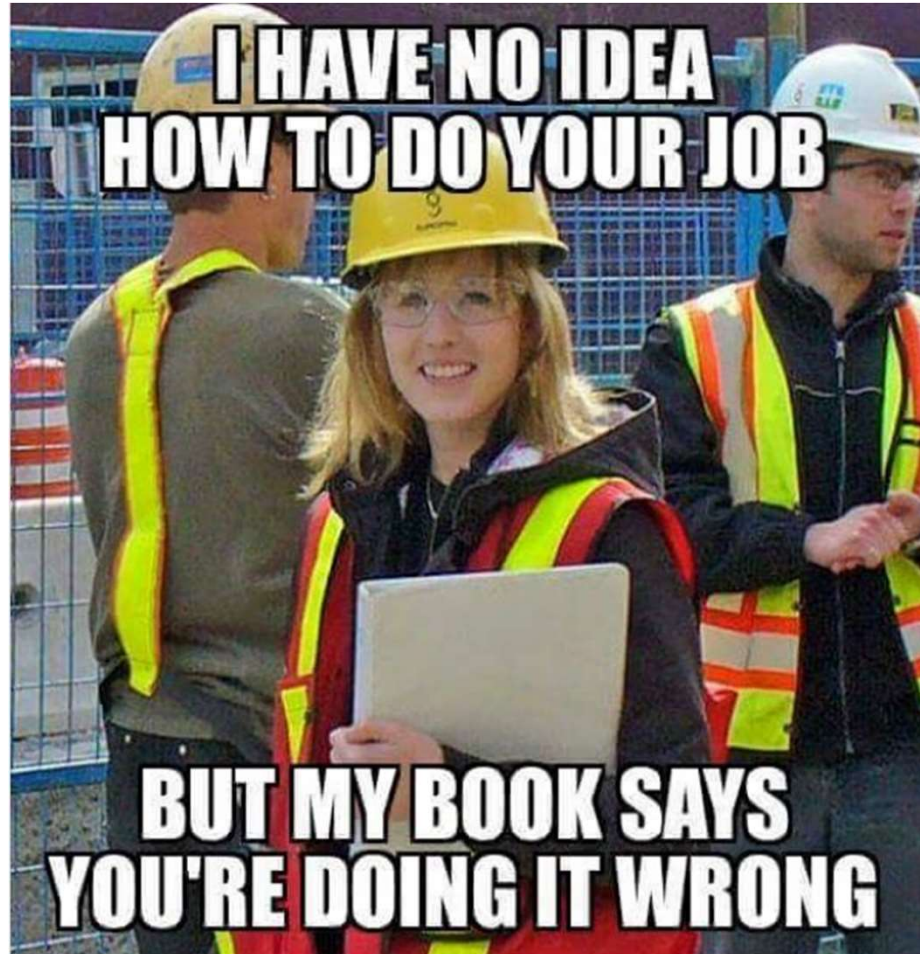

**I HAVE NO IDEA
HOW TO DO YOUR JOB**

**BUT MY BOOK SAYS
YOU'RE DOING IT WRONG**



- We will be talking about the cage, not so much the method we make it by.....like a cage machine or welded wire reinforcement.
- Now we are going to talk about how the plant production staff interprets the information they have been given to manufacture and assure that their practices result in Specification meeting, consistently **HIGH QUALITY CAGES** and why they are important to the finished quality of our products.



- We want to make cages correctly but **we all have different equipment**, some have vintage machinery that still performs as we need it to.
- Some have state of the art computer controlled.
- All Plant employees and supervisors need to understand the set-up and proficient operation of this equipment.
- We don't have the time required to get into those operation specifics today.



- **ASTM C822 Terminology**, states:
- “Cage”: an **assembled** unit of steel reinforcement consisting of circumferential and longitudinal bars or wires.
- Key word is **ASSEMBLED**; that’s what we do, and that’s why we are here today.



- First we will start with the specifications that we are all bound by.
- How many of you have **actually read the ASTM standards for the products you make?**
- Too often, that means you are counting on someone else to give you the right information.
- At the same time, **they are counting on you** to follow those directions accurately.
- **ALWAYS make sure that you are not interpreting that information to fit only what you or your equipment is capable of.**
- Virtually all the Specification specific points we will review today are exactly the same in C76, C1433 and C1577 so we will not be differentiating in the two specs types as we go.



ASTM Similarities Between Box & Pipe Specifications

- ASTM Standard: **C-76 Pipe**

1. Scope
2. Referenced Documents
3. Terminology
4. Classification
5. Basis of Acceptance
6. Materials
7. Design
8. Reinforcement
9. Joints
10. Manufacture
11. Physical Requirements
12. Permissible Variations
13. Repairs
14. Inspection
15. Rejection
16. Marking
17. Keywords

- ASTM Standard: **C-1577 Boxes**

1. Scope
2. Referenced Documents
3. Terminology
4. Designation
5. Basis of Acceptance
6. Material
7. Design
8. Installation
9. Joints
10. Manufacture
11. Physical Requirements
12. Permissible Variations
13. Repairs
14. Inspection
15. Rejection
16. Marking
17. Appendix X1: Design Criteria



SAFETY FIRST!





SAFETY FIRST!





SAFETY FIRST!





SAFETY FIRST!





SAFETY FIRST!





SAFETY FIRST!

- Always wear the proper PERSONAL PROTECTIVE EQUIPMENT for welding; leather gloves, welding sleeves or welding coat and safety glasses behind a welding helmet if that is the eye protection used

No Rings!.....Lost finger story.

Must Wear Gloves....LEATHER.

No Necklaces.

Others.....?



Packerhead Manufactured Concrete Pipe



BASIS of ACCEPTANCE

- C76 Section 5 states:
- Independent of the method of acceptance, the pipe shall be designed to meet both the .01 inch-crack and the ultimate strength requirements specified in the Tables for Class 1 through 5.



- Section 5.1 goes on to say:
- Acceptability of the pipe in all diameters and classes.....shall be determined by the results of the **THREE-EDGE BEARING TESTS**...
- Our efforts pass or fail as a result of a **PROOF TEST**...before the customer gets to typically try to take them to their limits.



Three Edge Bearing Test For Concrete Pipe





Three Edge Bearing Test





- Most importantly for this class;
Section 5.1.2 states:
- Acceptance on the **Basis of Materials Tests and Inspections....**
- Shall be determined by **the results...**
- By **inspection** of the **FINISHED** pipe
- INCLUDING **amount and placement** of REINFORCEMENT to determine its conformance with the accepted design and **its freedom from defects.**
- **Precisely what we are here for today!**



- Our job is to make certain our machinery **and our people** do what is required by these specifications.
- **If we fail** to make certain this happens consistently in our Plants, it is **certain our product will fail** these required proof tests and could fail were installed in the field.



ASCE C76 - 12a

TABLE 3 Design Requirements for Class III Reinforced Concrete Pipe^A

NOTE 1—See Section 5 for basis of acceptance specified by the owner.
 The strength test requirements in pounds-force per linear foot of pipe under the three-edge-bearing method shall be either the D-load (test load expressed in pounds-force per linear foot per foot of diameter) to produce a 0.01-in. crack, or the D-loads to produce the 0.01-in. crack and the ultimate load as specified below, multiplied by the internal diameter of the pipe in feet.

D-load to produce a 0.01-in. crack	1350
D-load to produce the ultimate load	2000

Internal Designated	Reinforcement, in. ² /linear ft of pipe wall											
	Wall A				Wall B				Wall C			
	Concrete Strength, 4000 psi				Concrete Strength, 4000 psi				Concrete Strength, 4000 psi			
	Wall Thick-	Circular		Elliptical	Wall	Circular		Elliptical	Wall Thick-	Circular		Elliptical
in.	Inner Cage	Outer Cage		in.	Inner Cage	Outer Cage		in.	Inner Cage	Outer Cage		
12	1 3/4	0.07 ^D	2	0.07 ^D	2 3/4	0.07 ^D
15	1 7/8	0.07 ^D	2 1/4	0.07 ^D	3	0.07 ^D
18	2	0.07 ^D	...	0.07 ^D	2 1/2	0.07 ^D	...	0.07 ^D	3 1/4	0.07 ^D	...	0.07 ^D
21	2 1/4	0.14	2 3/4	0.11	...	0.07 ^D	3 1/2	0.07 ^D	...	0.07 ^D
24	2 1/2	0.17	...	0.14	3	0.07 ^D	...	0.07 ^D	3 3/4	0.07	...	0.07 ^D
27	2 5/8	0.18	...	0.16	3 1/4	0.16	...	0.14	4	0.08	...	0.07 ^D
30	2 3/4	0.19	...	0.18	3 1/2	0.18	...	0.15	4 1/2	0.10	...	0.08
33	2 7/8	0.21	...	0.20	3 3/4	0.20	...	0.17	4 3/4	0.12	...	0.10
36	3	0.21	0.12	0.23	4 ^E	0.17	0.10	0.19	4 3/4 ^E	0.08	0.07	0.09
42	3 1/2	0.24	0.15	0.27	4 1/2	0.21	0.12	0.23	5 1/4	0.12	0.07	0.12
48	4	0.32	0.19	0.35	5	0.24	0.14	0.27	5 3/4	0.16	0.10	0.18
54	4 1/2	0.38	0.23	0.42	5 1/2	0.29	0.17	0.32	6 1/4	0.21	0.12	0.23
60	5	0.44	0.26	0.49	6	0.34	0.20	0.38	6 3/4	0.24	0.15	0.27
66	5 1/2	0.50	0.30	0.55	6 1/2	0.41	0.24	0.45	7 1/4	0.31	0.19	0.34
72	6	0.57	0.34	0.63	7	0.49	0.29	0.54	7 3/4	0.36	0.21	0.40
Concrete Strength, 5000 psi												
78	6 1/2	0.64	0.38	0.71	7 1/2	0.57	0.34	0.63	8 1/4	0.42	0.24	0.47
84	7	0.72	0.43	0.80	8	0.64	0.38	0.71	8 3/4	0.50	0.30	0.56
Concrete Strength, 5000 psi												
90	7 1/2	0.81	0.49	0.90	8 1/2	0.69	0.41	0.77	9 1/4	0.59	0.35	0.66
96	8	0.93	0.56	1.03	9	0.76	0.45	0.84	9 3/4	0.70	0.42	0.71
102	8 1/2	1.03	0.62	Inner Circular Plus Elliptical 0.41	9 1/2	0.90	0.54	Inner Circular Plus Elliptical 0.36	10 1/4	0.83	0.50	Inner Circular Plus Elliptical 0.33
108	9	1.22	0.73	Inner Circular Plus Elliptical 0.62	10	1.08	0.65	Inner Circular Plus Elliptical 0.54	10 3/4	0.99	0.59	Inner Circular Plus Elliptical 0.50
114	A	Inner Circular Plus Elliptical 0.73	10 1/2	1.17	0.76	Inner Circular Plus Elliptical 0.65	11 1/4	1.10	0.68	Inner Circular Plus Elliptical 0.59
120	A	A	A
126	A	A	A
132	A	A	A
138	A	A	A
144	A	A	A

^A For modified or special designs see 7.2 or with the permission of the owner utilize the provisions of Specification C655. Steel areas may be interpolated between those shown for variations in diameter, loading, or wall thickness. Pipe over 96 in. in diameter shall have two circular cages or an inner circular plus one elliptical cage.
^B As an alternative to designs requiring both inner and outer circular cages the reinforcement may be positioned and proportioned in either of the following manners:
 An inner circular cage plus an elliptical cage such that the area of the elliptical cage shall not be less than that specified for the outer cage in the table and the total area of the inner circular cage plus the elliptical cage shall not be less than that specified for the inner cage in the table,
 An inner and outer cage plus quadrant mats in accordance with Fig. 1, or
 An inner and outer cage plus an elliptical cage in accordance with Fig. 2.
^C Elliptical and quadrant steel must be held in place by means of holding rods, chairs, or other positive means throughout the entire casting operation.
^D For these classes and sizes, the minimum practical steel reinforcement is specified. The specified ultimate strength of non-reinforced pipe is greater than the minimum specified strength for the equivalent diameters.
^E As an alternative, single cage reinforcement may be used. The reinforcement area in square in. per linear foot shall be 0.30 for wall B and 0.20 for wall C.



- These **Tables**, **regardless of the shape** of the pipe indicate:
- **Pipe Diameter**
- **Wall Thickness**
- **Concrete Strength**
- **Cage Combinations allowed, using the specified Table areas or the options allowed by the footnotes.**
- 3 of these 4 are important to our cage making practices.



Cage Shape

- The “footnotes” from under **class 3 Table** are on the next page.
- We have choices; use **Table** designs or these “footnote” options for cage configuration. **Who decides that in your Plant...every job may have different requirements.**
- Remember; these options are very typical to all our different pipe shapes.
- We can spend more time on these if time permits at the end of the class. There is a huge amount of experience we can share **here in this room.**



Reference ASTM C76,
Table 3 Footnotes

A For modified or special designs see 7.2 or with the permission of the owner utilize the provisions of Specification C655. Steel areas may be interpolated between those shown for variations in diameter, loading, or wall thickness. **Pipe over 96 in. in diameter shall have two circular cages or an inner circular plus one elliptical cage.**

B As an alternative to designs requiring both inner and outer circular cages the reinforcement may be positioned and proportioned in either of the following manners:
An inner circular cage plus an elliptical cage such that the area of the elliptical cage shall not be less than that specified for the outer cage in the table and the total area of the inner circular cage plus the elliptical cage shall not be less than that specified for the inner cage in the table,

An inner and outer cage plus quadrant mats in accordance with Fig. 1, or

An inner and outer cage plus an elliptical cage in accordance with Fig. 2.

C Elliptical and quadrant steel must be held in place by means of holding rods, chairs, or other positive means throughout the entire casting operation.

D For these classes and sizes, the minimum practical steel reinforcement is specified. The specified ultimate strength of non-reinforced pipe is greater than the minimum specified strength for the equivalent diameters.

E As an alternative, single cage reinforcement may be used. The reinforcement area in square in. per linear foot shall be 0.30 for wall B and 0.20 for wall C.

Are you making the most cost effective cage design for your process?

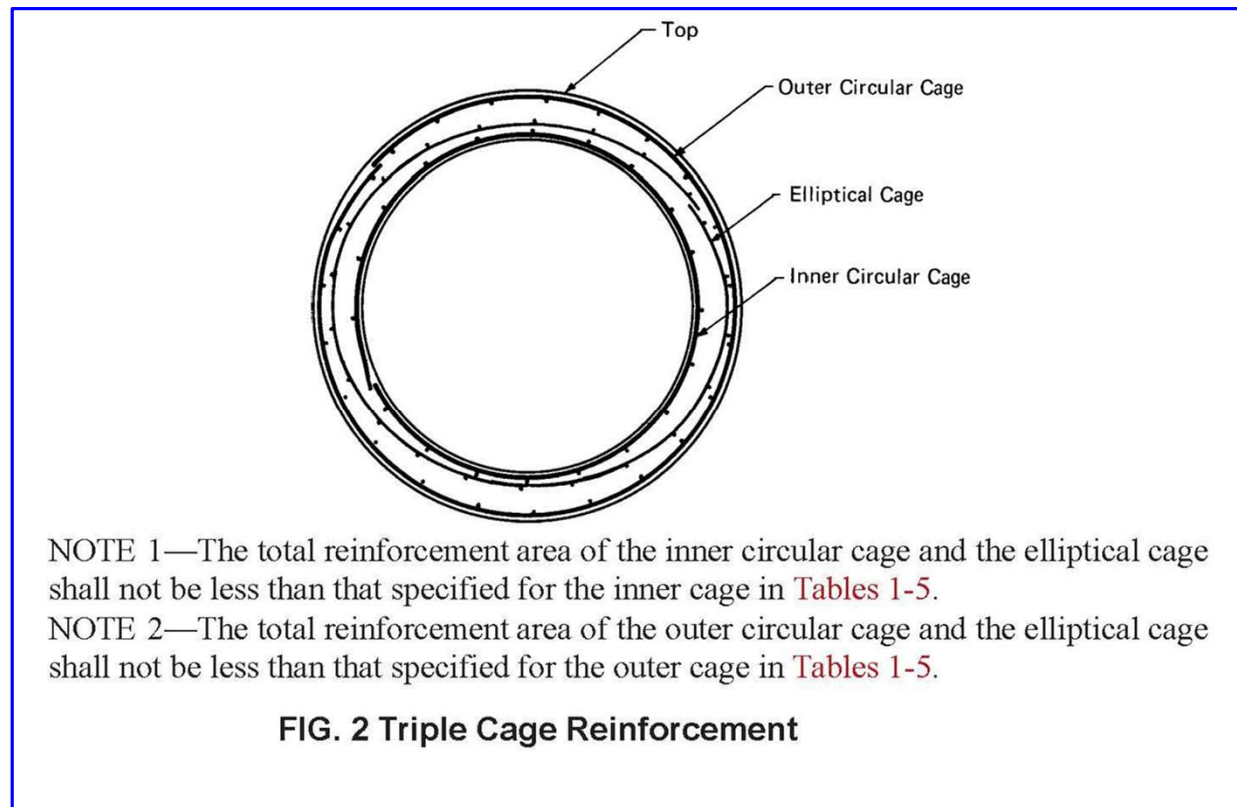

Reference ASTM C76,
Figure 2.

- This method can be used on any RCP pipe shape.



Will your cage hold it's shape through the production process?





Plant Practices



- If your wire is coming off your roller like this:



Call your supplier if WWF is feeding off the roll squarely and it looks like this....AND, check your rollers shafts condition.

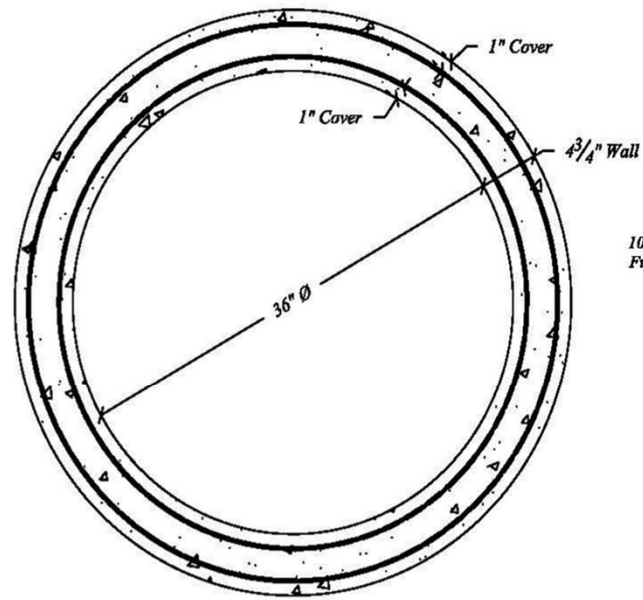

Typical Cage

36" Ø x 4 3/4" Wall

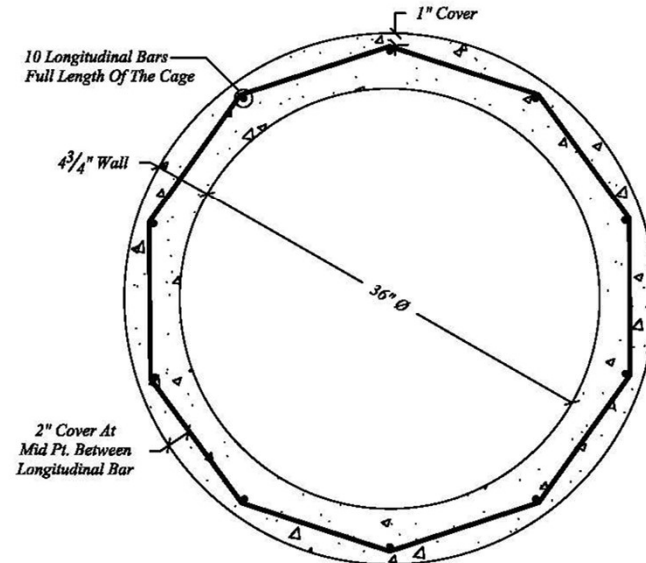

**Stop Sign Shape Cage
w/ 10 Longitudinal Bars
(Out of Spec)**

Will your cage hold it's shape
through the production process?



Plant Practices

Cording Causes:

- Wire is pulled too tight
- Wire is too brittle
- Too much weld roller pressure
- Too much Heat
- Too much weld time
- Welding timing off.....welding after contact



Does your cage stand straight? Your pipe won't with these cages!



Is there tension in your cage post-pour? There sure will be with these!





Plant Practices

Poor cage machine set up

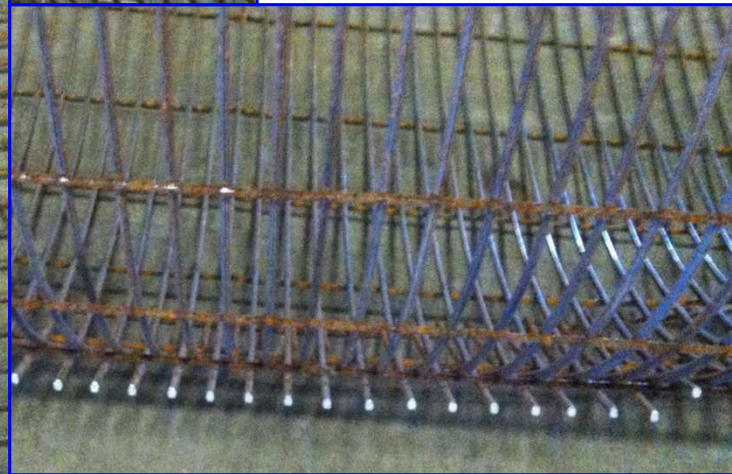

This is not a machine set up class.

- If you're dry casting, you can't save this cage by spacing it to the form or a parallel cage in the same pipe wall.
- Besides that, it is likely out of spec!



Improper Mesh Rolling Machine Set Up



Cage Machine Set Up w/ Safety Bar Through The Cage



Cage Machine Set Up w/ Safety Bar Through The Cage



- C76 Section 8: REINFORCEMENT
- “LINE” of reinforcement definition: circumferential reinforcement comprised of one or more layers.
- “LAYER” of reinforcement definition: circumferential reinforcement that is one bar or wire in thickness.
- We have to have them in the right shape and place, regardless of how we get the required area.



www.concrete-pipe.org



- C76 Section 8.1.1:
- Where ONE LINE of reinforcement is used...the circular reinforcing should be placed 35 to 50% of the wall thickness from the inner surface of the pipe,
- except for wall thickness less than 2½", the protective cover of the concrete over circumferential reinforcement in the wall of the pipe shall be ¾".



Plant Practices:

- Cage **SHAPE** is our #1 in-plant cage production problem
- Our Associates are ready to help your Plant with their problems; **please use the opportunities the Contacts list in the Appendix gives you.**

- **Trying to promote some questions here!:**
- **What can put a cage out of shape? This gives us the most problems:**
 - Roller improperly adjusted.....too tight.....too open
 - Too few transverse (longitudinal) wires
 - Convolute bell wire expansion...Not concentrically centered?
 - What dimension are we supposed to be at?
 - Do you have tapered forms? Measure top and bottom of cage
 - All legs the same length to prevent wobble
 - Too hot of welder settings distorting the cage
 - Dropping the cage from the roller or cage machine
 - Dragging the cage can bend the legs
 - Tipping cages can distort the bells
 - Improper handling jigs or rigs not pulling uniformly on the cage.



Plant Practices

- Is your wire clean?
- No oil or grease. No dirt. No tags. No paint. etc.....
- RUST: if it has not reduced the diameter of the wire, it will only enhance pipe strength. It will affect welding on cage machines.
- **What does poor wire cleanliness hurt?**



Plant Practices

- Always check the first cage of the cage machine or the wire roller!
- Cages need to be stood up on a pallet when required, to see if they fit. Do not completely weld a WWR cage until this has been determined so adjustments can be made if necessary. **Be cautious not to damage the cage standing it up or laying it back down. Wire size and cage diameter matters.**
- What is the appropriate way to measure a round cage? **Diameter; top bottom and halfway up, dependent on the diameter of the cage. Circumference is important. You can not just do one or the other of these checks!** Understand ratio of diameter to circumference?.....3.14?
- **The BELL-WIRE diameter also needs to be checked if it is a separate ring or an expanded/convoluted bell wire per QCast.**



- How do you determine the cage size (diameter and circumference)? **Anyone want to review this?** It is based on the wall thickness and diameter of the pipe.
- How do you determine the proper length of material to roll out of WWR to have a proper diameter cage and the proper lap?
Anyone want to review this?
- **Questions?**



Cage Shape – Handling Holes & Handling Devices (Lift Eyes)

- Section 8.1.7 states:
- The continuity of the circumferential reinforcing steel shall not be destroyed.....
- Except that when agreed upon by the owner, lift eyes or holes may be provided in each pipe for the purpose of handling.



- Plant Practices

Cautions:

- 2” circumferential wire spacing in an 8’ lay length pipe: if you **cut** TWO wires for a handling hole and you have cut 2 of 48 which is a **4.2% reduction**.
- Welding handling devices is **restricted** only in certain box culvert locations and has further consideration **required when using shear reinforcing**. More on this in the back of this program.





Cutting lift holes; how big can the hole be? **Contractor story.....**

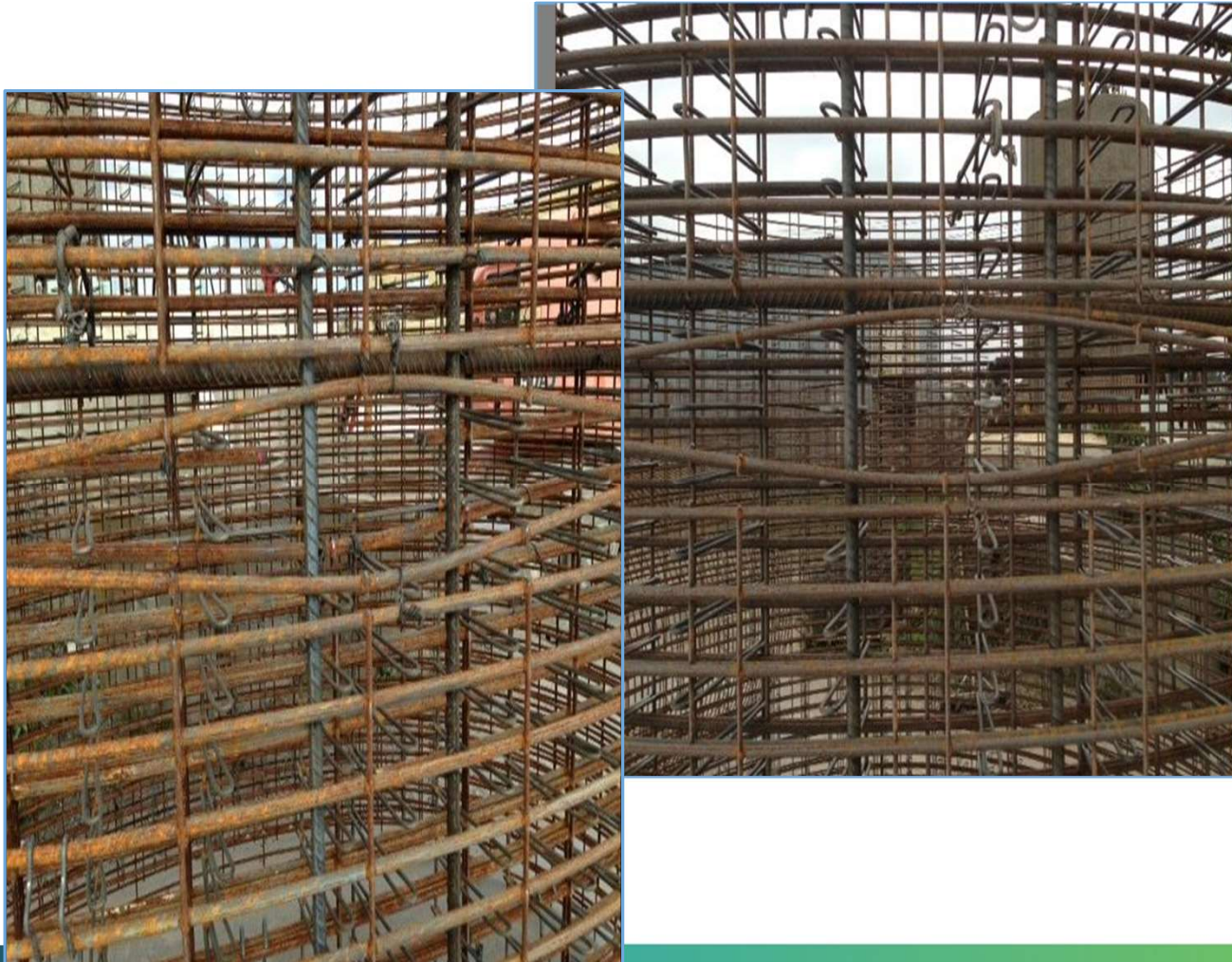





Cage Length

C76 Section 8.1.5 States:

- The spacing **center to center of circumferential reinforcement** in a cage shall
- **not exceed 4"** for pipe up to and including pipe having a **4" wall thickness**
- **nor exceed the wall thickness** for larger pipe,
- and shall **in no case exceed 6"**.

C76 Section 8.1.6 states:

- Where the wall reinforcement does not extend into the joint,
 - The maximum longitudinal distance to the **last circumferential** from the inside shoulder of the bell or the shoulder of the spigot **shall be 3"**
 - except that if this distance exceeds one-half the wall thickness, the pipe wall shall contain at least a total reinforcement area of the minimum specified area per linear foot times the laying length of the pipe section.
 - **The minimum cover** on the last circumferential near the spigot shoulder **shall be 1/2"**
-
- Where reinforcement in the bell or spigot the **minimum end cover** on the last circumferential **shall be 1/2" in the bell or 1/4" in the spigot**



PERMISSIBLE VARIATIONS: Position of Reinforcement Section 12.3:

Length of Two Opposite Sides:

- Variations in laying length of **two opposite sides** of the pipe shall not be more than **1/4"** for all sizes through **24" internal diameter**,
- and **not more than 1/8"/foot** for all sizes larger with a **maximum of 5/8"** in any length of pipe through **84" internal diameter**,
- and a **maximum of 3/4"** for **90" internal diameter or larger**,

- **Section 12.4 Length of Pipe:**

- The **underrun in length** of a section of pipe shall **not be more than 1/8"/foot**
- with a **maximum of 1/2"** in any length of pipe
- **Regardless of the underrun** or overrun in any section of the pipe, the **end cover requirements of Sections 8 & 12 shall apply.**

- While these two Sections are not directly about the cage, **our cage permissible variations and location requirements are greatly affected by the pipe product manufacture process and can put us out of spec** if all these details are not monitored by ALL Plant staff....there must be **exceptional communications** between the cage making crew and the packerhead machine operating crew!

- All the checks on this slide (plus wall thickness and ID's) are required to be checked and recorded by QCast.



Cage Location in the Product Wall

C76 Section 8.1.7:

- **The continuity of the circumferential reinforcing steel shall not be destroyed during the manufacture of the pipe,**
- **In other words: the location and shape of the cage has to be maintained during the pipe handling and manufacturing process.**

C76 Section 16.2; Marking:

- One end of each section of pipe with ELLIPTICAL or QUADRANT reinforcement shall be clearly marked during the process of manufacturing or immediately thereafter,
- on the inside AND the outside of opposite walls along the minor axis of the elliptical reinforcing or along the vertical axis for quadrant reinforcing.



C76 Section 8.1 Circumferential Reinforcement:

- A **line** of circumferential reinforcement for any given total area may be composed of
 - **2 LAYERS** for pipe with a wall thickness of **less than 7"** or
 - **3 LAYERS** for pipe with wall thicknesses of **7" or greater**.

- The **LAYERS shall not be separated** by more than the thickness of **one longitudinal wire plus 1/4"**.
- The multiple **LAYERS** shall be fastened together to form a single cage.

- All other specification requirements....., shall apply to this method of fabricating a **LINE of Reinforcing**.



C76 Section 8.1.1 Circumferential Reinforcement continued:

- Where **ONE LINE** of circular reinforcement is used,
- It shall be placed from **35 to 50% of the wall thickness** from the **inner surface** of the pipe,
- **except for wall thicknesses less than 2.5"**, the **protective cover** of the concrete over the circumferential reinforcement in the wall of the pipe **shall be $\frac{3}{4}$ "**.



C76 Section 8.1.2; Circumferential Reinforcement continued:

- In pipe having **2 LINES** of circular reinforcement,
- **each LINE** shall be so placed that the **protective covering** of concrete over the circumferential reinforcement in the wall of the pipe **shall be 1"**.
- This 1" CIRCUMFERENTIAL reinforcement cover is most typical in the most of the products we manufacture by ASTM standards.



C76 Section 8.1.3; Circumferential Reinforcement continued:

- In (**round**) pipe having ELLIPTICAL reinforcement
- with wall thicknesses $2\frac{1}{2}$ " or greater, the reinforcement in the wall of the pipe shall be so placed that the protective covering of concrete over the circumferential reinforcement shall be 1" from the inner surface of the pipe at the VERTICAL diameter
- and 1" from the outer surface of the pipe at the HORIZONTAL diameter.
- In pipe having ELLIPTICAL reinforcement with wall thicknesses less than $2\frac{1}{2}$ ",
- the protective covering of the concrete shall be $\frac{3}{4}$ " at the VERTICAL and HORIZONTAL diameters.

C76 Section 8.1.4; Circumferential Reinforcement continued:

- The location of the reinforcement **shall be subject to** the **PERMISSIBLE VARIATIONS** in dimensions given in 12.5.



ASTM C-76 – Section 12 Permissible Variations

- Standard Specification for Reinforced Concrete Culvert, Storm Drain, and Sewer Pipe
- Sections:
 1. Scope
 2. Referenced Documents
 3. Terminology
 4. Classification
 5. Basis of Acceptance
 6. Materials
 7. Design
 8. Reinforcement
 9. Joints
 10. Manufacture
 11. Physical Requirements
 - 12. Permissible Variations**
 13. Repairs
 14. Inspection
 15. Rejection
 16. Marking
 17. Keywords
 18. Tables: Requirements for Class I through V Reinforced Concrete Pipe
 19. Figures and Details



- **12. Permissible Variations**
- 12.1 Internal Diameter
- 12.2 Wall Thickness
- 12.3 Length of Two Opposite Sides
- 12.4 Length of Pipe
- 12.5 Position of Reinforcement
 - 12.5.1 Position
 - 12.5.2 Area of Reinforcement



- **The Details:**
- **12.1: *Internal Diameter*:** 12" – 24" shall not vary by more than 2% - 1.5% per linear scale
- 27" and larger shall not vary more than 1% or +/- 3/8", whichever is greater
- All based on an average of FOUR diameter measurements

- **12.2 *Wall Thickness*:** Shall not vary more than shown on design or specified wall by more than +/- 5% or 3/16", whichever is greater
- A specified wall thickness more than required in the design is not cause for rejection.
- Pipe having localized variations in wall thickness exceeding those specified above shall be accepted if the three-edge-bearing strength and minimum steel cover requirements are met.



- 12.3 *Length of Two Opposite Sides: 12" -24"*: Variations in the laying length of two opposite sides of the pipe shall not be more than $\frac{1}{4}$ " internal diameter
- 27"- 84": not more than $\frac{1}{8}$ " per ft. with a $\frac{5}{8}$ " maximum
- 90"- 144": $\frac{3}{4}$ " maximum
- Except for beveled pipe for specified by owner curve pipe

- 12.4 *Length of Pipe*: The underrun in length of a section of pipe shall not be more than $\frac{1}{8}$ " per ft with a maximum of $\frac{1}{2}$ " in any length of pipe. Regardless of the underrun or overrun in any section of the pipe, the end cover requirements of Sections 8 and 12 apply.



- 12.5 *Position or Area of Reinforcement:*
- 12.5.1 *Position* – The maximum variation in the position of a line of circumferential reinforcement shall be $\pm 10\%$ of the wall thickness or $\pm \frac{1}{2}$ in., whichever is greater. **Pipes having variations in the position of a line of circumferential reinforcement exceeding those specified above shall be accepted if the three-edge-bearing strength requirements obtained on a representative specimen are met.** In no case, however, shall the cover over the circumferential reinforcement be less than $\frac{1}{4}$ in. as measured to the end of the spigot or $\frac{1}{2}$ in. as measured to any other surface of the pipe or joint. The preceding minimum cover limitations do not apply to mating surfaces of nonrubber gasket joints or gasket grooves in rubber gasket joints. If convoluted reinforcement is used, the convoluted circumferential end wire may be at the end surface of the joint providing the alternate convolutions have at least 1 in. cover from the end surface of the joint.



- 12.5.2 *Area of Reinforcement* – Reinforcement will be considered as meeting the requirements if the area, computed on the basis of nominal area of the wire or bars used, equals or exceeds the requirements of 7.1 or 7.2. Actual area of the reinforcing used may vary from the nominal area according to permissible variations of the standard specifications for the reinforcing. When inner cage and outer cage reinforcing is used, the inner cage nominal area may vary to the lower limit of 85% of the elliptical nominal area and the outer cage nominal area may vary to the lower limit of 51% of the elliptical nominal area provided that the total nominal area of the inner cage plus the outer cage shall not vary beyond the lower limit of 140% of the elliptical nominal area.



PERMISSIBLE VARIATIONS: C76 Section 12.5; Position or Area of Reinforcement:

- Section 12.5.1 Position:
- The **maximum variation** in the position of a **LINE** of circumferential reinforcement **shall be +/- 10% or +/- 1/2"**, **whichever is greater.**
- **Pipes having variations in the POSITION of a LINE of circumferential reinforcement exceeding those specified above SHALL BE ACCEPTED if the three-edge-bearing strength requirements obtained on a representative specimen are met.**

- One test can sometimes **bail you out**....you need to be certain you comply with the "representative specimen".....don't just be testing the best one!



C76 Section 12.5.2; Area of Reinforcement:

-Actual area of the reinforcing used may vary from the nominal area according to PERMISSIBLE VARIATIONS or the standard specifications for the reinforcing.
- When inner cage and outer cage reinforcing is used,
- the inner cage nominal area may vary to the lower limit of 85% of the ELLIPTICAL nominal area
- and the outer cage nominal area may vary to the lower limit of 51% of the ELLIPTICAL nominal area
- provided that the total nominal area of the inner cage plus the outer cage shall not vary beyond the lower limit of 140% of the ELLIPTICAL nominal area.
- Nominal Area Definition: (not stated in ASTM C822): Theoretical area required.



36" Ø x 4" Wall

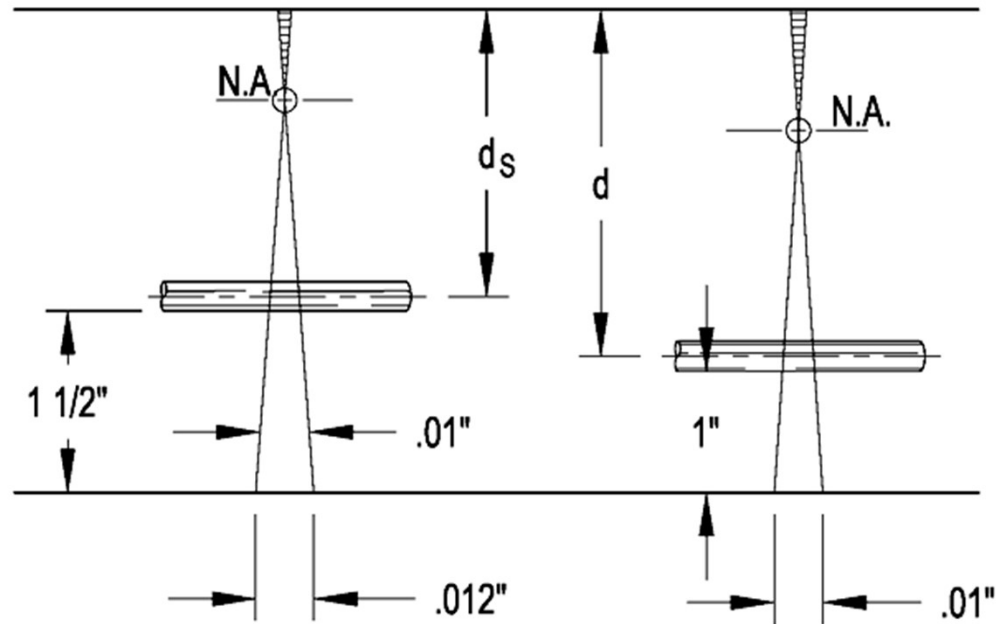

**Moving Steel in to 1 1/2" From 1" Cover
 Requires an INCREASE in Steel by
 47% Due to shorter d and due to
 cracking geometry.**



36" \emptyset x 4" Wall



AS d = Resistance to crack width

d. Min = 147% to required steel

d. Nom. = 100% of required steel

d. Max = 77% of required steel

D-Load would vary by 34% if we used the allowed cage position tolerance from C76.

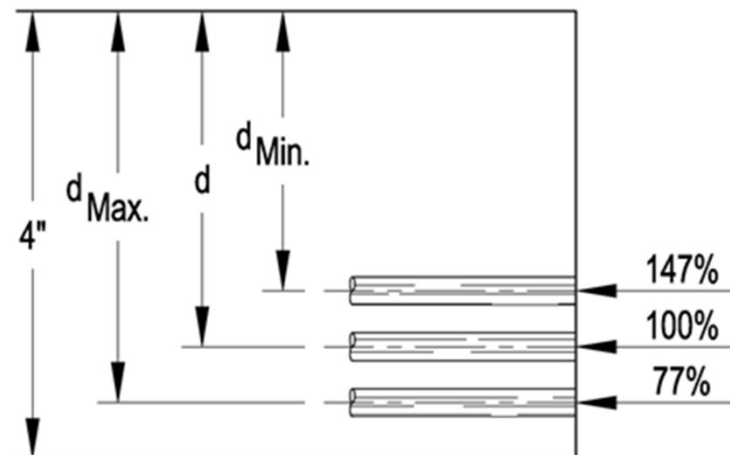



Plant Practices

- If open ends of WWR are sticking out, pound them level with a 2# hammer so they are level with the cage.
- For Double Wrapped (2 [Layers](#)):
- Inner: the inside dimension always stays the same.
- Outer: always shrink the outer cage 3" from a normal lap. The second layer will make up the circumference to have the cage outer diameter the proper dimension.



Specifically Packerhead Reinforcement

- **Note:** These comments are the experience of a few very experienced packerhead machine operators. There is very little written guidance provided when you buy a machine.
- **There is no such thing as one size fits all!**
- **Some producers have been very successful** at using minimal steel allowed by specification.
- **Not all producers are equipped to have the same success!**



Packerhead Specific Pipe Cages

Cage Machines and Mesh Rollers can both produce wire cages to meet [ASTM specification](#) to be run on a Packerhead Machine, and each have been used successfully by producing companies.





Cage Machines

- Cage Machines are ordered to fit a specific number of **longitudinal wires**: 12L, 18L, or 24L. Each of these machines can produce a cage using $\frac{1}{2}$ of the longitudinal bars and **this is most critical on a Packerhead machine**. Commonly an 18L machine is chosen.
- If your Packerhead machine produces 54" thru 84" RCP then a 24L cage machine might be recommended to keep the space between the longitudinal bars tighter together.
- Cage machines can be made to spin clockwise or counterclockwise wind of the steel. It would be beneficial to **use a cage machine that winds opposite the rotation of the roller head**.
 - If you look at the rotation being right hand from above as turning CCW. If the cage machine produces CCW wind, **it effectively becomes a corkscrew for the roller head** making it **easier for the head to overcome the steel**. This also makes a more sturdy cage and **can allow a more aggressive packing process**.



Cage Machines

- A cage machine can allow the producer to choose using **less longitudinal wires** and/or placing circumferential **wire further than 4" apart** for pipe with a Wall greater than 4" thick....up to 6" maximum.
- The cage machine allows flexibility and can save money when buying reinforcing steel, based on how many wires you actually require to meet specification tolerance and quality standards.
- Remember, when we have **more longitudinal wires**, we have more support of the circumferential wire and we will be less likely to damage the cage during the production process.
- A very experienced **STERN WARNING**: If **YOU** remove too many longitudinal wires, or reduce the wire diameter too much, **YOU will have performance issues in the field!** This leads to more product rejections, failures, and scrapped products than most of us are **willing to risk!**



PLANT PRACTICES:

Cage Machine Cages:

Past scarcity and the price of WWR is causing some manufacturers to **switch** from Wire Mesh (WWR) to cage machine use for Packerhead cages.

The **concrete distribution forces** found in the PH process require special caution when making your cages this way.

Besser and a few **ACPA producing members** were kind enough to share some of their critical points for this method, here are some tips to help you be successful should you have to chose this method: From **Besser**:

“We try to keep the spacing to a minimum of 2” and a maximum of 3”. If the spaces are too small, the **pipe may not be packed** as well as it needs to be by a bi-di machine. If the gaps are too large we get concerned about **slabbing.**” ...ACPA Member

Per Scott Kennedy at Besser: “Remember **on packerhead machines, longitudinal wires are critical.**”

“ASTM says to use only as many as required to hold the circumferential in place. When centrifugal force is applied by a packerhead **it is imperative to have enough straight wires to support the pressure and force being applied.**”

“ It is nearly impossible to pack concrete with a packerhead **through a space less than 2”**. It goes on to further say we can exceed 4” when the wall is greater than 4”, **BUT we cannot have spaces greater that the wall thickness at any time.**”



Plant Practices Continued:

“At no time would I allow the spacing go below 2” and the gap between longitudinal wires should not exceed 10”. EXCEPT for an outer cage.”

“With cage machines of all makes, we need to pay attention to the **pressure being applied by the weld bar**. MORE IS NOT BETTER. Too much pressure applied here makes the circumferential wire flat and it **should be round for strength and positioning**.”

“Longitudinal wires per size **PACKERHEAD**

12-18 6 to 9 space between L is 5-7” or 7-10.75 (18) I used 9 because I wanted to make a pipe that would stand at attention and perform its ass off.

24-30 12-18 space between L is 4.5-7 or 6-9 for 30” I used 18L

36 single cage 18-24 space between L is 5-7” I used 18L

Cage diameter*3.1415/#of longitudinal wires. Striving to stay less than 10” IMO.

Last sample 72” inner is 74”. Using my math a 24 L machine is required to keep the spacing just under 10”

ASTM covers the size of wrap to size of L requirements. It is feasible to use less L IF the L diameter is bigger. I have never seen an L larger than W3. If this is the cage I have never seen a wrap wire over W6.”

“**Checking welds** is a highly sophisticated use of a tool. The machine manufacturer will sell you one. After you lose it, buy a 12” adjustable wrench. **The L should bend before the weld pops**. It is very important to **weld at a speed that makes the weld good**.”

“FYI to keep up with a high production machine, it will likely require 2 cage machines running 10 hour shifts, especially when two cages are required.”



Cage Machines

- The cage **longitudinal wires are the skeleton** the pipe stands on that influence **the ability for the product to stand upright, stay round, and parallel.**
- The fewer longitudinal wires, the **more likely we are to twist the cage**, especially when observing 35% of the wall thickness single cage tolerances.
- The closer we get to the inside diameter of the RCP, the more critical the size and number of longitudinal wires become.



PLANT PRACTICES Continued:

Thank you to **Matt Durband and Carl Carlson at CEMCAST Pipe and Precast** for their willingness to share their experience with our class:

This has not been without some trial and error. One of the biggest problems we ran into was the quality of welds produced. Without good welding the cage will inevitably fail while the pipe is being produced. **Nobody wants to torch a cage out of the roller head.** Good welding starts with the **cleanliness of the wire.** We run 2 types of wire through our machine. **Bright basic** which is already drawn down to the specific sizes we use and is relatively clean, and **green rod** which we draw down ourselves and is in its raw state. Bright basic needs to be stored inside and kept free of rust. Green rod is kept outside and is descaled as it is run through the machine. **To ensure that we are spooling the cleanest wire we can we have added addition wire scrubbers to the drawing line.** This also helps with any drawing lube residue left on the wire used during the wiring drawing procedure. Our machine has the capability to run 6, 12, or 24 longitudinal wires. The rack that supplies the longitudinal wires holds all 24 spools of wire. The spools on the rack last considerably longer than the spool used for the circumferential wire. Although the wire has been cleaned before it reaches the rack, **the likelihood of this wire sitting there for awhile is very probable.**



Especially if you are going to be running pipe that are just using 12 longitudinal wires. Because of this we **have added additional wire scrubbers** to the longitudinal wires between the rack and the machine. This just helps to ensure that we are getting the **cleanest possible wire we can at the point of welding**. So assuming we now have the cleanest wire that we can, the next process is to make sure that all of the components of the machine are satisfactory. The groove in the welding wheel must not be over half the thickness of the circumferential wire. If you are running a .250 wire and then switch to a .177 wire, the depth of the groove in the welding wheel will more than likely be too deep to run the .177 thus creating very poor welding. The welding wheel will need to be re-machined to decrease the depth of the groove. We keep a few different wheels on hand as to not have down time while a wheel is in maintenance getting re-machined. Along with the welding wheel the slide dies(hold the longitudinal wire) have to be checked for depth also. So now we have clean wire and a machine that meets the requirements for good welding. **Next is to set the appropriate welding power. This gets a little more tricky because you want a good weld, but you don't want to over weld the wire. Welding a .177 circumferential to a .20 longitudinal is not going to take as much power as welding a .391 circumferential to a .20 longitudinal.**



We have developed ways **to do spot checks on the welds** (one of those secrets), so you don't have to cutout and analyze welding all the time. I have caught the **operator increasing welding over the course of a few days** while running the same size wire. This is indication that some of the components on the machine need to be looked at. It's a temporary fix, but **we are not sure the type of weld we are getting if they are constantly switching the welding power**. All of this mentioned above is standard for all cages of all sizes being made. We basically run 4 sizes of wire through our machine. .177, .20, .250 and .391. There are a lot of variation in these wire sizes to obtain the specific area needed for a specific class of pipe. What we have found is **that if your pitch of the circumferential wire gets too wide or too small you will have problems with your pipe. Too wide and you get slabbing off and too small you wont be able to get the material through the cage**. Sometimes we will tighten up pitch of the cage just to ensure no slabbing will occur. **We very seldomly have this due to the cage being very round and the correct diameter**. To keep the cages round once you get to the bigger sizes cages the use of 24 longitudinal is used. We have found the 12-42 we can get away with 12 longitudinal wire. Anything above 42 cage we use 24 wires. This **prevents the cage from looking like a stop sign and keeps the circumferential at the correct clearance**.



Cage Machine example - We are making 24" C-76-III-B RCP

- If we use a 12L cage machine,
 - reduce the number of longitudinal wires to 6
 - with a cage diameter to 26"
 - making .08 area using .195 longitudinal bars.
 - This results in longitudinal **13.5" apart**. We are in spec though, **right??**
- However; being that close to the ENERGY (rollerhead), and the skeleton being so stretched apart, **this cage WILL twist.**
- **So, how can we keep this from happening?**



Plant Practices Continued:

From **Tom Jennings at Fred Weber:**

These are some of the tips that we use to ensure quality cages for packer head pipe production.

1. We turn the welder up to the point that wires are coping in to each other approximately 50% longitude to circumferential wrap wire.
2. Second we also try to use the **maximum amount of longitudes to keep the cage as round as possible with no flat spots between the longitudes.**
3. We perform **occasional pry tests** with a piece of notched flat stock on the circumferential wire to ensure proper bonding and penetration of the weld. **If the weld pops with a 45° bend or less is generally not strong enough.**
4. It is also important to **have cage centered at 50% or halfway in on the bells on the bottom flange of the pallet** so that the wire is not too close to the pallet so concrete can move between the pallet and the cage **for proper consolidation in the bell joints**



Cage Machine example - We are making 24" C-76-III-B RCP

- **Option 1**
 - Use 12 longitudinal wires and make the space between them just under 7" apart.

- **Option 2**
 - Take advantage of the [ASTM C-76 Section 12.5](#) following those permissible variations to get the cage as far away from the roller head as allowable tolerance possible **to still pass a 3 edge bearing test**. Can you make strength? **I personally will NEVER tell you to take this risk!**

- **Option 3**
 - Use less pack pressure
 - **THIS IS NOT AN OPTION!** But it is what some producers do and their products suffer because of that. **You can't make strength.**



Plant Practices

- In our plants, we stand the first 3 cages. If they measure the same circumference and the lap is the same, we are making good cages.
- Take another circumferential measurement towards the end of a roll, just to make certain nothing has changed.
- Do not roll the cage too small in diameter. It will create a flat or indent on the lap with the open end sticking out, which ever way you wrap it.
- Make certain a cage is secure before you take it off the roller and before you stand it to measure it. You may not want to have it completely welded in case you have to make a change, but you have to make certain all employees are clear from the possibility of the cage sliding open and cutting them.
- A strap or vise-grips can also accomplish this.



Plant Practices

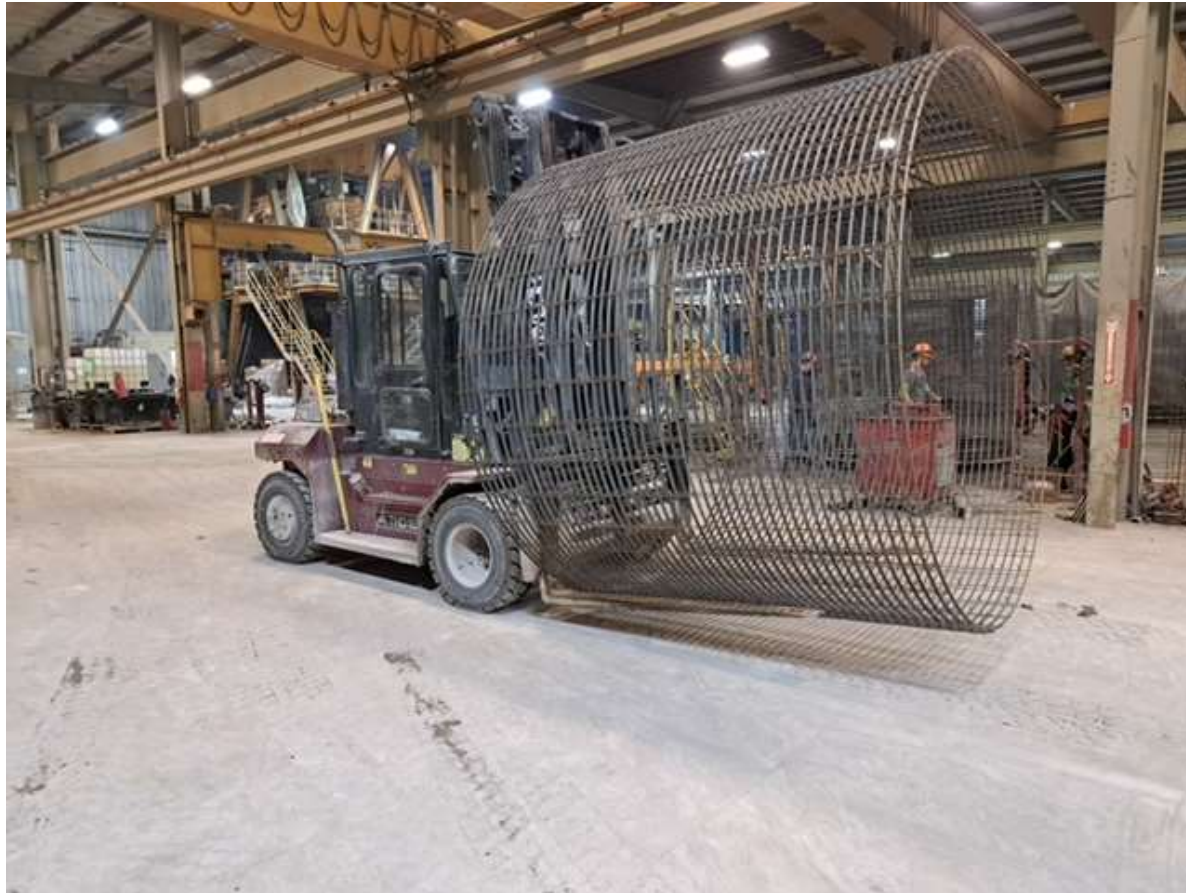

Cradling Cage



Plant Practices

- A few things we do to ensure a round pipe is delivered to the pallets.
- Radius gages to check the wire is broke at the correct radius at the start of each cage coming off the mesh roller before gravity effects measuring, must have round cage.
- Marking each pallet so the seams are in the correct position before clipping, stirrups and lift holes are installed.
- Standing large bore cages to ensure they stay round, cradling cages from the bottom so as not to stretch them while they are being transported and mated or brought to production area.



Plant Practices

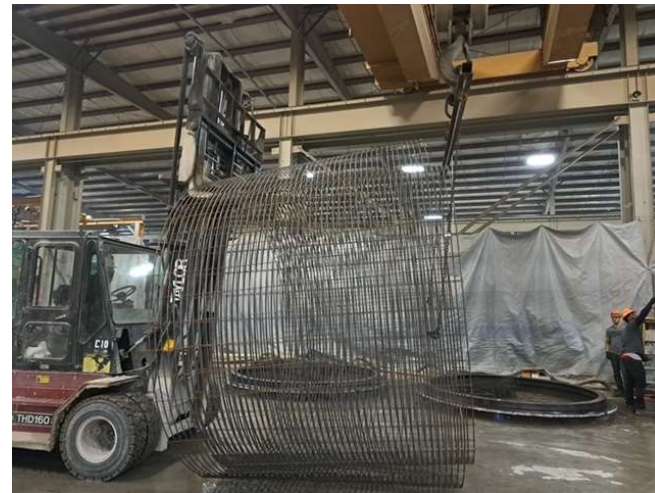



Plant Practices

- Providing a safer entry and egress inside cages for stirrup installation, tools and supplies lowered and raised and not climbing with them.





Plant Practices

- A simple jig for lift hole installation. Trying to ensure they are at the correct location, heights and help eliminate mistakes by a misread tape measure or marking wrong. A simple visual aid. We use a torpedo level to keep them plumb so that the crew only moves or removes the minimum amount of steel around lift holes. This also helps when cages are loaded. The hole formers fit proper to speed up production.





Splices, Laps, Weld Gates

Section 8.1.8 States:

- If splices are not welded, the reinforcement shall be lapped not less than 20 Diameters for deformed bars and deformed cold worked wire, and 40 diameters for plain bars and cold drawn wire.
- In addition, where lapped cages of welded-wire fabric are used WITHOUT welding, the lap shall contain a longitudinal wire.
- Example: 20 diameter of a W8 wire which is .319" in diameter is 6.38" lap required.
- Example: 40 diameters of a W8 wire is 12.76" lap required. Both: including a Longitudinal wire.

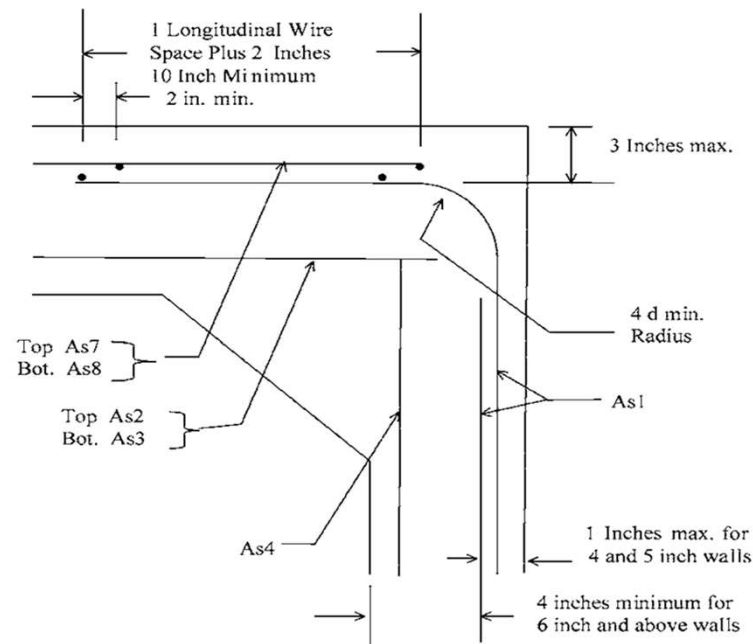

ASTM C-1433, FIG. 5 Detailed Reinforcement Arrangement



- If your company prefers to use short laps for your wire splices instead of the typical minimum required of 2 bars plus 2" as shown here, you must do your welding satisfactorily.
- You don't have to be a certified welder or an expert but these basics that we are going to review today are critical to your delivering the best pipe products available.
- Always wear the proper PERSONAL PROTECTIVE EQUIPMENT for welding; leather gloves, welding sleeves or welding coat and safety glasses behind a welding helmet if that is the eye protection used.





Section 8.1.8.1 States:

- When splices are welded and not lapped to the minimum requirements above, there shall be a minimum lap of 2" and a weld of sufficient length such that pull test of representative specimens shall develop at least 50% of the minimum specified TENSILE strength of the steel.
- For BUTT-WELDED splices in bars or wire, PERMITTED WITH ONLY HELICALLY WOUND CAGES, pull tests pull tests of specimens shall develop at least 75% of the minimum specified TENSILE strength of the steel.





Plant Practices



Position of the lap:

- At the Crown?
 - At the Invert?
 - At the Spring line?
-
- Recommended place is at 45 degrees to any quadrant.
 - If two cages, put the splices in different quadrants. **WRI fig 5, (in 2 slides)**
 - **If three cages, put the splices in different quadrants. WRI fig 8, (in 2 slides)**



Plant Practices

- What determines if the lap is overlapped or interlapped?
- When producing a pipe requiring a double cage design (2 LINES) (inside and outside cages), some of our members prefer:
- For the inside cage; It is best to weld the wire tails to the outside of the cage
- For the outer cage; it is best to weld the tails to the inside cage.
- This placement of the cage tails will ensure proper concrete coverage from the jacket and from the core.

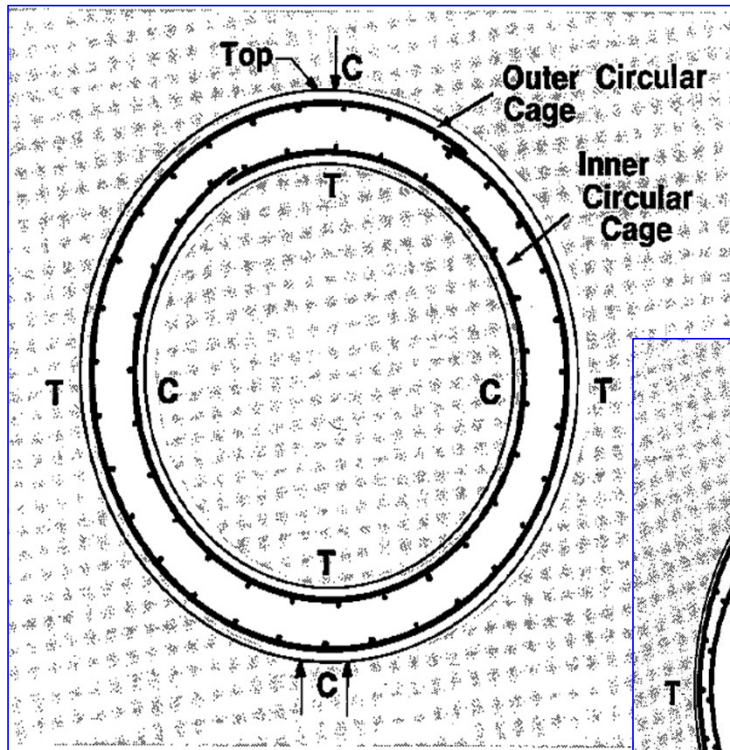

WRI Fig 5

WRI Fig 8

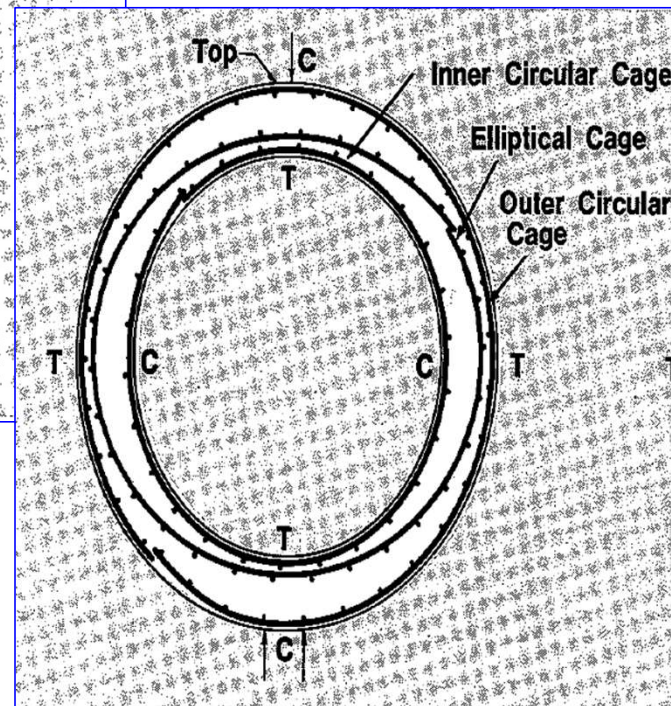



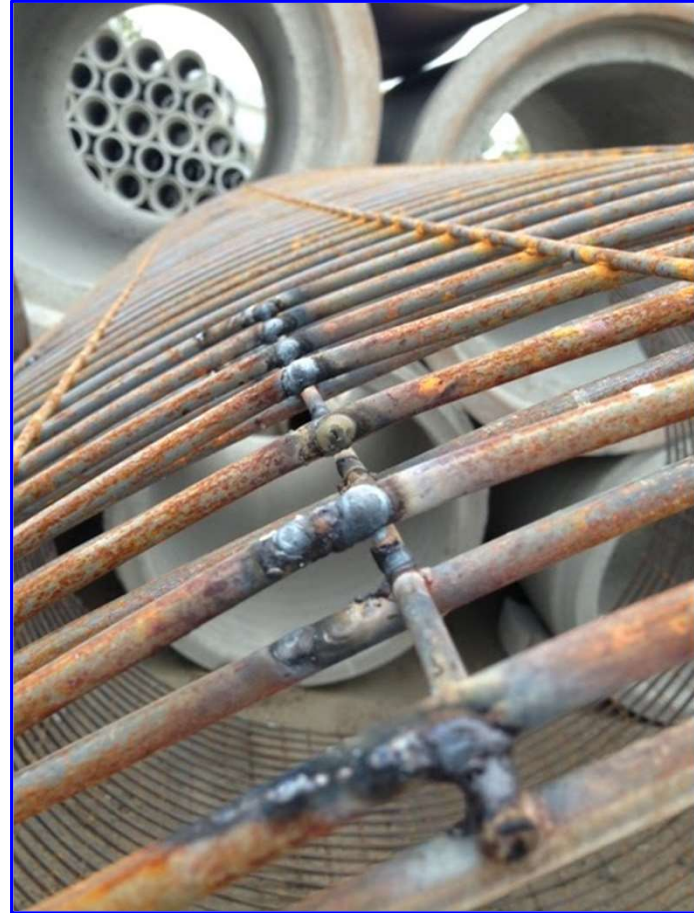



- Another option, if you are using long enough laps and you don't have qualified welders, is to tie the lap with hog-nose rings, horizontal spacers from longitudinal to longitudinal, bag-ties or other mechanical fastening methods.
- Depending on the manufacturing process, you have to be very certain how rigid these connections are or they can come apart during the manufacturing of the pipe.
- **With a proper lap and a secure tying system, this method will work just as well. However, just remember, it is NOT as strong as a welded cage for the pipe manufacturing process.**
- **Is a welded cage better than, worse or equal to a tied cage? Non welded laps are NOT recommended for Packerhead production.**



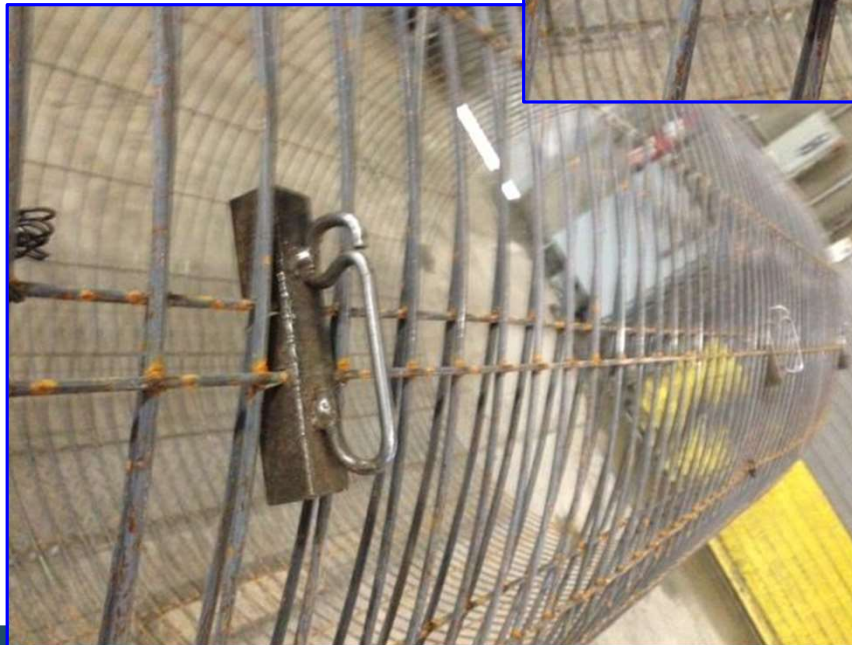



Plant Practices

A good description shared to me by one of our members:

- “We have a guy at our plant who is pretty proficient with cage fabrication. He uses a tool that has notches to hold the cage laps at the proper spacing. A few ties from the tie gun to hold the cage, then a wire-feed welder to finish the cage.
- He utilizes a piece of 4” angle iron on the floor (about 4’ long) to hold the cage against while welding. He places a cross-wire from the cage up against the angle iron to hold the cage while welding it.
- The angle iron keeps the cage from moving and helps keep the cage square while it is welded.
- The ground cable from the welder is attached to the angle iron so he can move the iron and ground where he needs to in his area for welding different cages.
- At the end of the day it can be picked up and put away.”



Other tricks that can be shared by the audience?



Welding: Splices, Laps, Weld Gates

- Please take the time when you get back home from the Pipe School, to go to the [ACPA Members Only](#) section of their web site and download the PROPER REINFORCING WELDING PRACTICES.
- You will find a great amount of welding specifications, knowledge and proof testing on various wire sizes and various weld sizes and rod grades.
- You will also find some critical guidance on other welding we commonly consider doing in our Plants.



Reference ASTM C-1417
Manufacture of Reinforced
Concrete Pipe by Direct
Design Pipe

10.3 *Welds:*

10.3.1 For butt splices of circumferentials or where welds are made to circumferentials, pull tests of representative specimens of the circumferential across the finished weld shall demonstrate a strength of no less than 1.1 times the design yield strength of the circumferential except as provided in 10.4.

10.3.2 At the option of the manufacturer, a more detailed analysis may be made and the requirements of this section used instead of 10.3.1. For butt splices of circumferentials or where welds are made to circumferentials, pull tests, P_t , of representative specimens of the circumferential across the finished weld shall demonstrate a strength of no less than:

$$P_t = 1.1 A_{wr} f_y \quad (1)$$

or no less than:

$$P_t = 0.5 A_{wa} f_y \quad (2)$$

whichever is greater.

10.4 *Lapped Splices of Circumferential Reinforcement:*

10.4.1 Where lapped circumferentials are spliced by welding, they shall be lapped no less than 2 in. Pull tests of representative specimens shall develop no less than 0.9 times design yield strength of the circumferential.

10.4.2 At the option of the manufacturer, a more detailed analysis may be made and the requirements of 10.4.2 and 10.4.3 used instead of 10.4.1. Where lapped circumferentials are spliced by welding, they shall be lapped no less than 2 in. Pull tests, P_t , of representative specimens shall develop no less than:

$$P_t = F_w A_{wr} f_y \quad (3)$$

or not less than the strength required by Eq 2, whichever is the greater.









- Welding on the reinforcing is critical to strength of the products we build. The weld can determine if our products pass the proof testing (3EB) in our Plants and is imperative to our products performing as they are designed to do in the field.
- Welding is the most common problem area I find in visiting pipe plants.....whether it is cage machines that are too hot, have missed the welding zone or manual welding done to our cages with a stick or wire feed welder, these welds have to be done well!
- **Poor welds** is one thing I personally **will never just walk by** regardless of whose facility I am in.
- Too many plants put their guy there that just doesn't seem to catch on anyplace else...wrong way! **Everyone should get experience, and in some cases, should start in the wire room to learn how critical cage making requirements and efforts are.**

Effects of Undercut

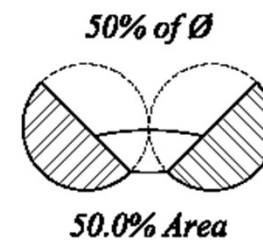
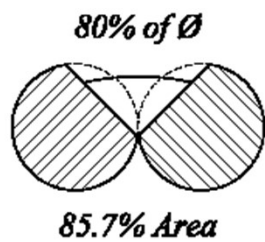
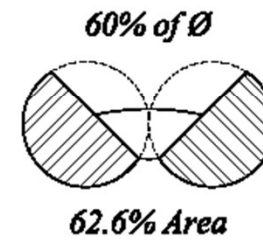
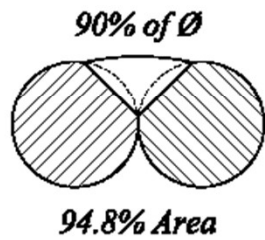
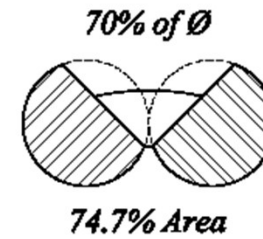

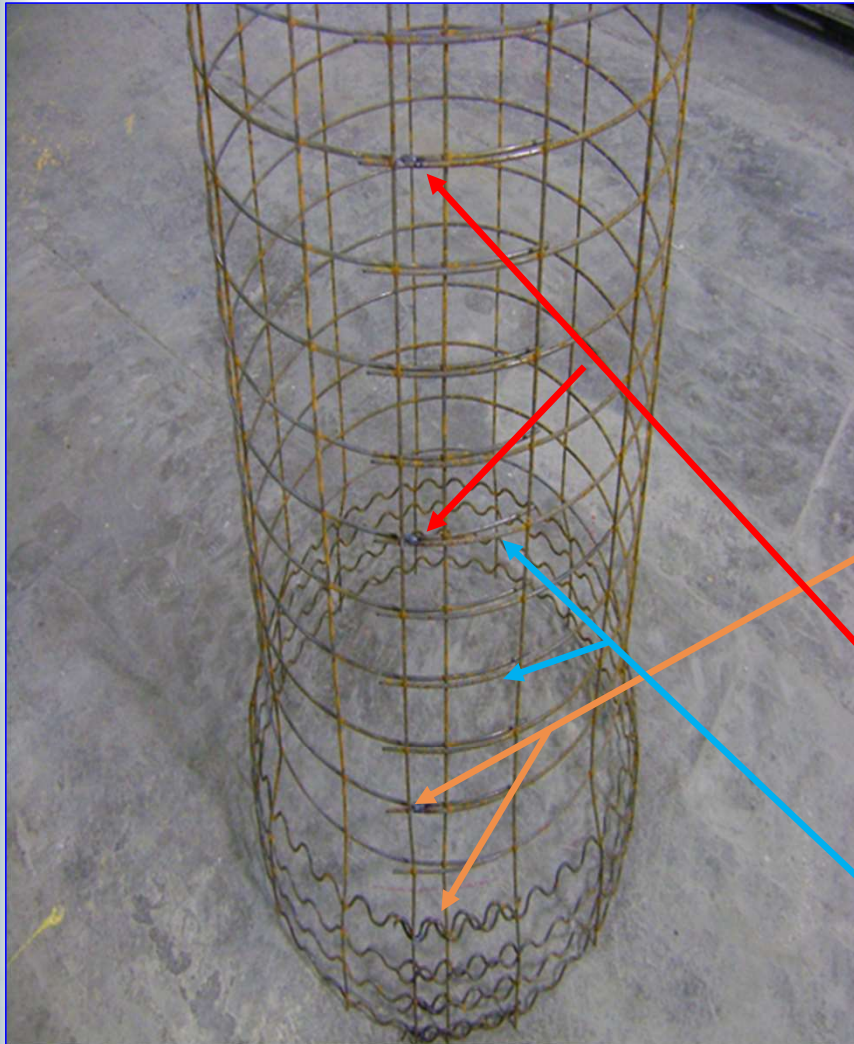

Cage Fabrication Do's

-Wire ties not used on this cage. Wire ties are not needed on a cages that have the proper number and spaced welds. Waste of time and wire ties.

-Welds are **properly located** in the bell and barrel areas of the cage

-**Correct number of welds** that are located consistently from the bell area to the cage spigot

-Wire tails are **rolled to match the contour of the cage** and are located so they will not be exposed through the concrete

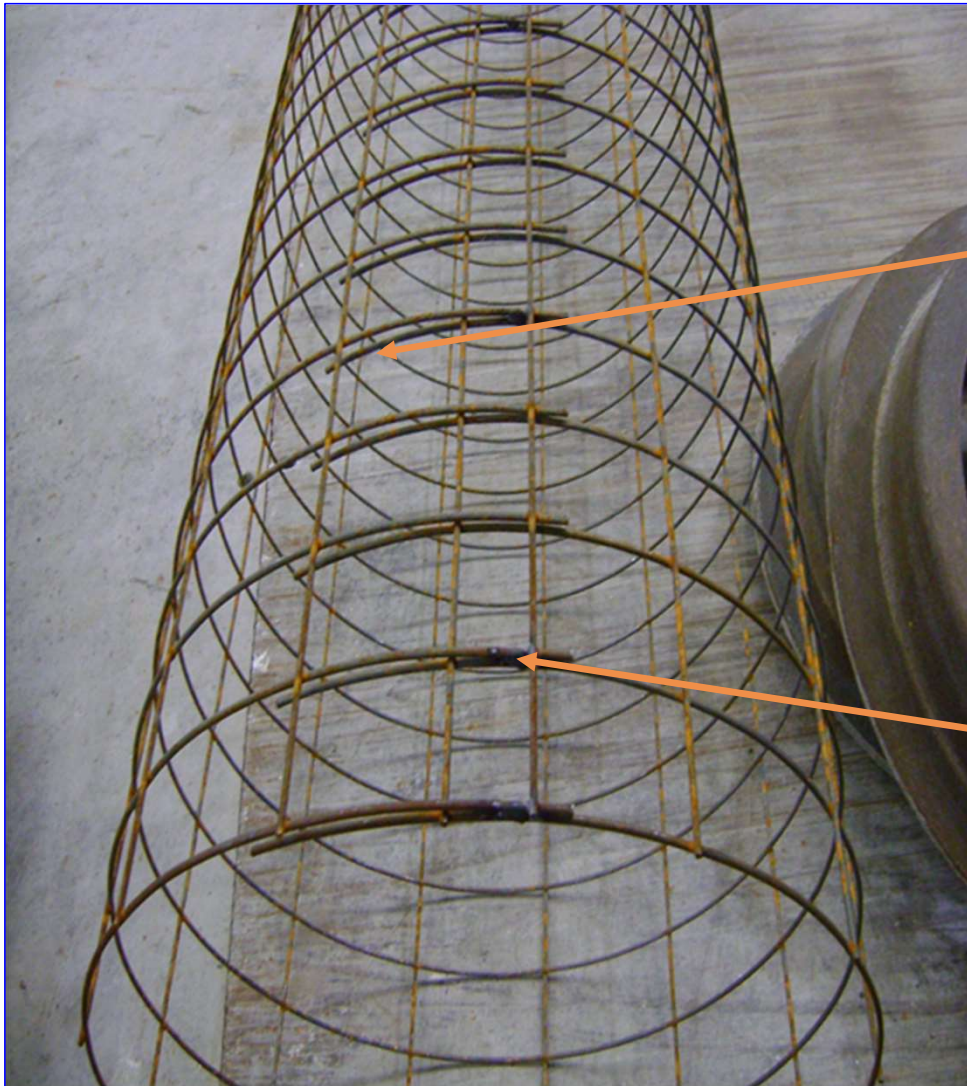

Cage Fabrication Do's:

-Wire tails are rolled to match the contour of the cage and tails are on the inside of the cage decreasing the chance of having exposed steel on the pipe

-Clean welds spaced properly on the cage will hold the cage laps together eliminating the need for wire ties

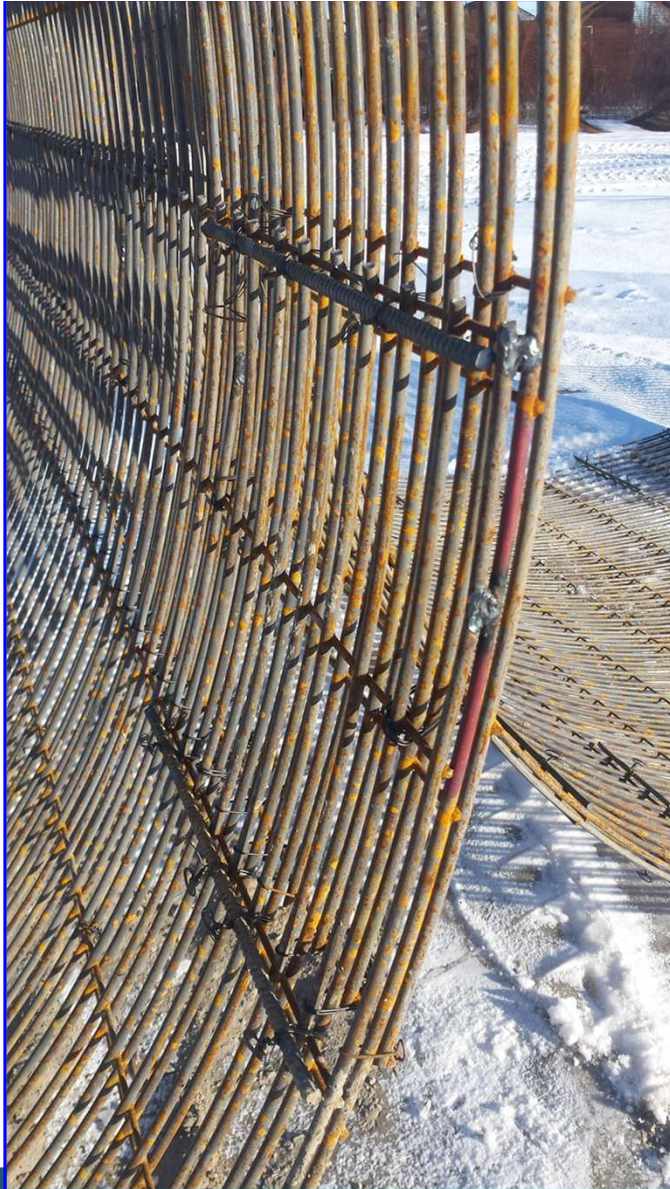

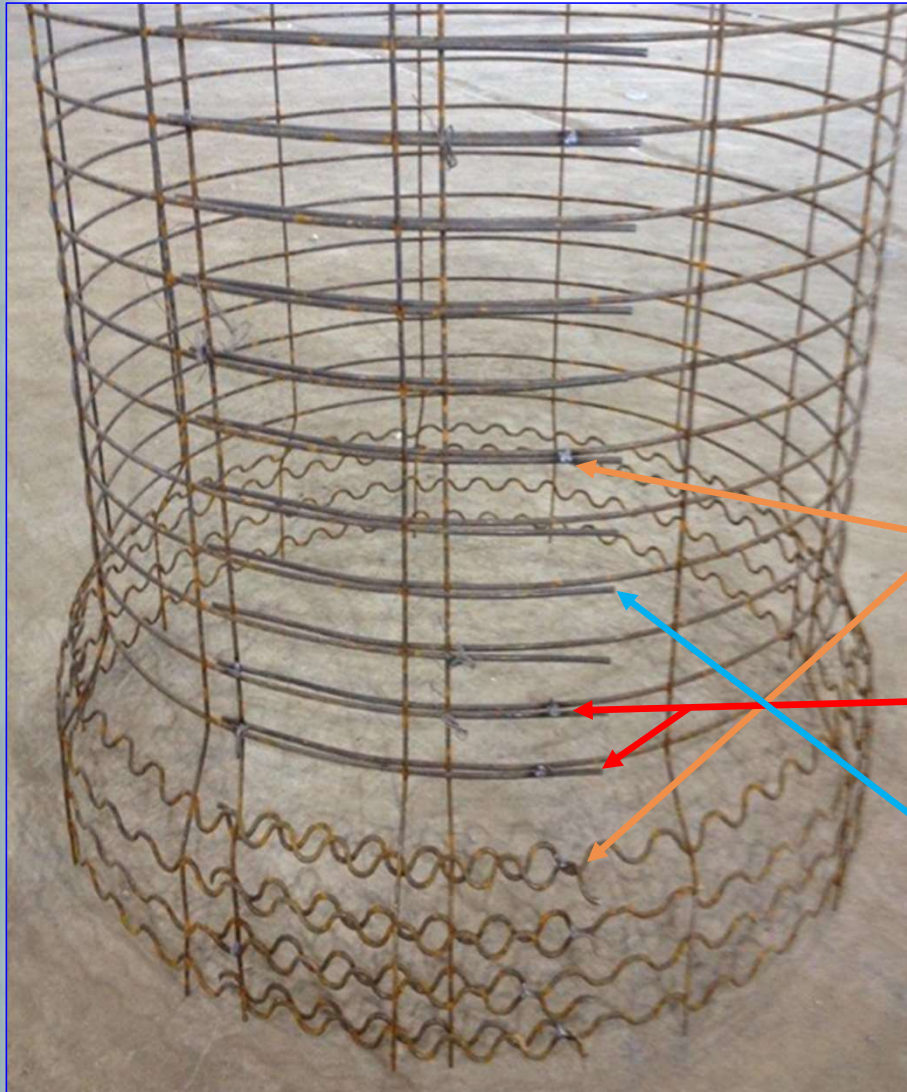

Cage Fabrication Do Not's Example:

- Excessive use of wire ties, generally speaking these are not needed on packer head cages, waste of time and wire ties
- Improper location of welds in bell and barrel areas of the cage
- Excessive number of welds on the cage
- Wire tails not rolled to match the contour of the cage and the tails are pointing outward



Cage Fabrication Do Not's:

-Wire tails not rolled correctly, want wire tail ends rolled inward to better match the profile of the cage, run the risk of having steel exposed. Make adjustments to wire roller

-Do not need to use wire ties and welds. Use minimal or no wire ties and then weld cage ends together. Using extra wire ties is a waste of time and wire ties. Also run the risk of having exposed wire ties through the concrete

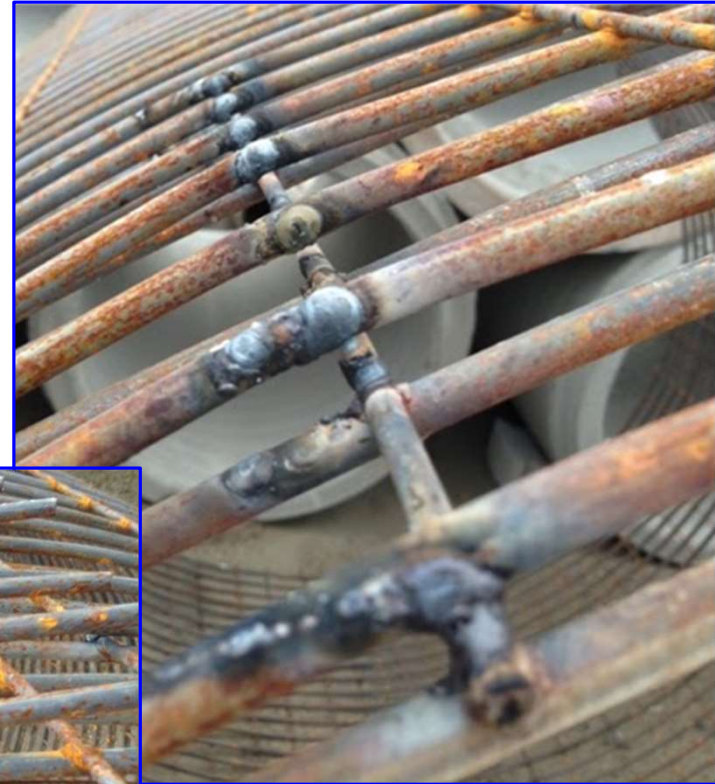

Additional slides to follow this
with two lines of welds.....why?
just makes a flat spot!





Plant Practices

- What do you do when you have a cage out of shape, from whatever cause?
- Do you use heat to re-shape the wire?

*Not unless you are trained and know how to measure the temperature of the steel and what temp is appropriate for the specific carbon content you are working with.



Plant Practices

- When a cage is NOT MEASURING across both ways at it should; one way to save it; example:
- A 42" inner cage should measure 44" x 44". If it measures 42" x 45", it can be pounded out by laying the cage back down, putting the seam up on, outside and between two parallel 2" x 4". Just pound gently with a light sledge hammer and it will go to the correct measurement.
- A poor weld will not hold up to typical pipe machine vibration, just like a miss-timed cage machine will not have strong enough welds to stand up to the production process.



Example of Potential Disaster

48" B wall **ASTM** Specification Design

C-76-II Inner: .18 sq in/ft

Outer: .11 sq in/ft

C-76-III Inner: .24 sq in/ft

Outer: .14 sq in/ft

We're going to weld a Class III inner wire and assume an 25% undercut by a poor welder.



.240 sq in/ft with 2" wire spacing
= 6 wires per foot of pipe
W4 wire = .04 sq in/wire

$(.04 \text{ sq in}) \times (.75\% \text{ of nominal wire area}) \times 6 \text{ wires/ft} = .180 \text{ sq in/ft}^*$

*This actually then takes the Class III wire down to a **Class II reinforcement area!!**

- **Your welder is supplying your customer and his project owner with a product of less capacity than they have designed and are going to pay for. This will be setting our entire industry and your company up to look very poorly and could conceivably cause a serious injury.**



Look what happens to a very small wire like
a .120 area with 3" wire spacing.

= 4 wire per foot of pipe

= .03 sq in/ft

$(.03 \text{ sq in}) \times 75 \% \times 4 \text{ wires} = .0897 \text{ sq in/ ft}$

.120 sq in/ ft vs .0897 sq in/ft

Don't assume this poor job is consistently done right; there could be less than 25% of the pipe strength not delivered to the job site due to careless work on OUR part.



Wire Size	Nominal Diameter	Actual Diameter	Area in ²	As (in ²) 3" oc	At 80% Diameter	As (in ²) 2" oc	At 80% Diameter
W3	0.195		0.0299	0.120	0.102	0.180	0.153
W4	0.226		0.0401	0.160	0.136	0.240	0.204
W6	0.276		0.0598	0.240	0.204	0.360	0.306
W8	0.319		0.0799	0.320	0.272	0.480	0.408
W10	0.357		0.1000	0.400	0.340	0.600	0.510
W12	0.391		0.1200	0.480	0.408	0.720	0.612
At 80% of the diameter, the loss due to a poor weld is ~85% of As.							



Ultimate Test Results w/6013 Welding Rod

W10 Smooth Welded Wire (Good Welds)								
Weld Length	Test #1 (Lbs)	Test #2 (Lbs)	Avg. (Lbs)	Nominal Dia. (in)	Actual Dia. (in)	Area (in ²)	50% of Yield (Lbs)	90% of Yield (Lbs)
Spot (Tack)	1600	1793	1697	0.357	0.357	0.100	3500	6300
1/4"	2944	2922	2933	0.357	0.357	0.100	3500	6300
3/8"	3167	3020	3094	0.357	0.357	0.100	3500	6300
1/2"	4031	4078	4055	0.357	0.357	0.100	3500	6300
3/4"	4905	4640	4773	0.357	0.357	0.100	3500	6300
1 1/4"	6540	6655	6598	0.357	0.357	0.100	3500	6300
W12 Smooth Welded Wire (Good Welds)								
Weld Length	Test #1 (Lbs)	Test #2 (Lbs)	Avg. (Lbs)	Nominal Dia. (in)	Actual Dia. (in)	Area (in ²)	50% of Yield (Lbs)	90% of Yield (Lbs)
Spot (Tack)	1608	2053	1831	0.389	0.391	0.120	4200	7560
1/4"	3735	4128	3932	0.389	0.391	0.120	4200	7560
3/8"	3855	4574	4215	0.389	0.391	0.120	4200	7560
1/2"	5366	5273	5320	0.389	0.391	0.120	4200	7560
3/4"	6239	6374	6307	0.389	0.391	0.120	4200	7560
1 1/4"	6694	7447	7071	0.389	0.391	0.120	4200	7560



Plant Practices

- It is our experience, from our Plant testing, that a good weld from 6013 rod, that has it's base at TWO TIMES the diameter of the wire being welded, is sufficient to meet the ASTM welding requirements.
- You have to verify this within your own Plants operations before you adopt this practice.



Joint Reinforcement

Section 8.3.1: Joint Reinforcement for NON-RUBBER GASKET JOINTS

- 36" diameter pipe or larger: Either the BELL OR the SPIGOT shall contain circumferential reinforcement.
- This reinforcement shall be an extension of the wall cage, or maybe a separate cage of at least the area per foot of that specified for the outer cage or ONE-HALF of that specified for single cage wall reinforcement, whichever is less.
- The maximum end cover on the last circumferential shall be one-half the length of the joint or 3", whichever is less.



Single Cage Guidelines

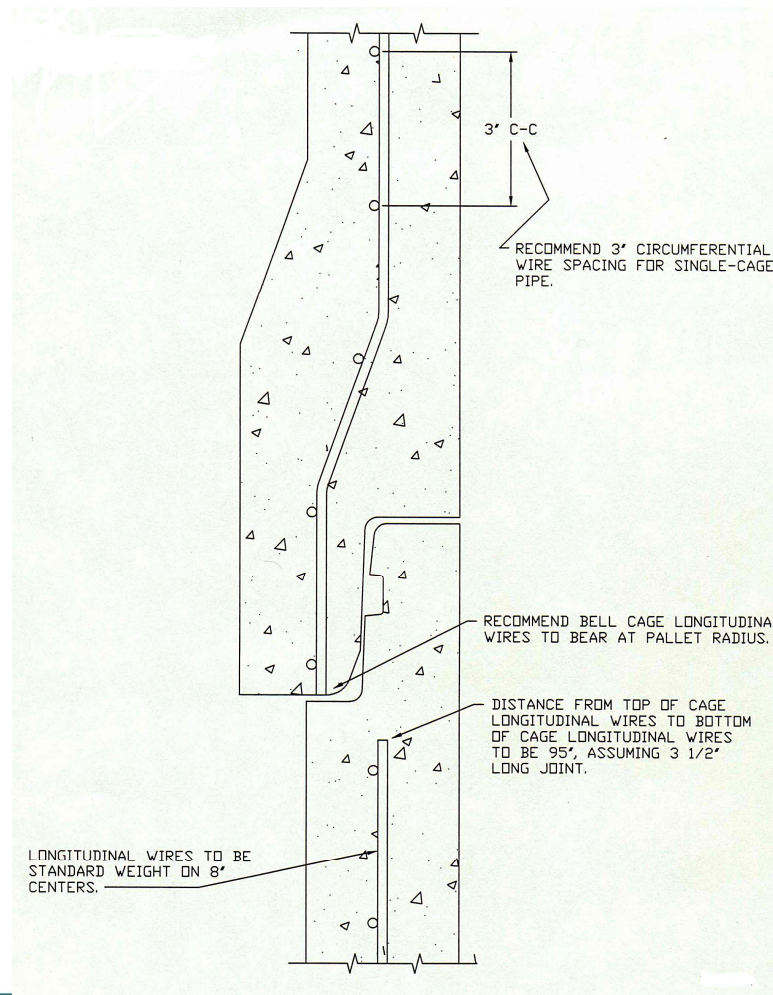



Double Cage Guidelines

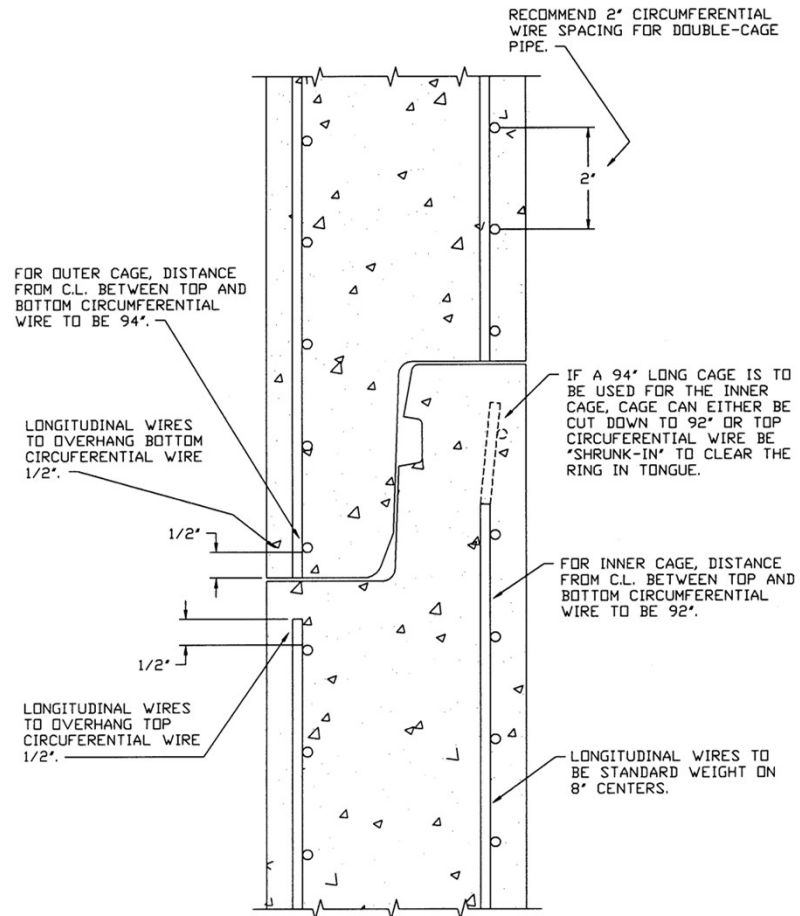
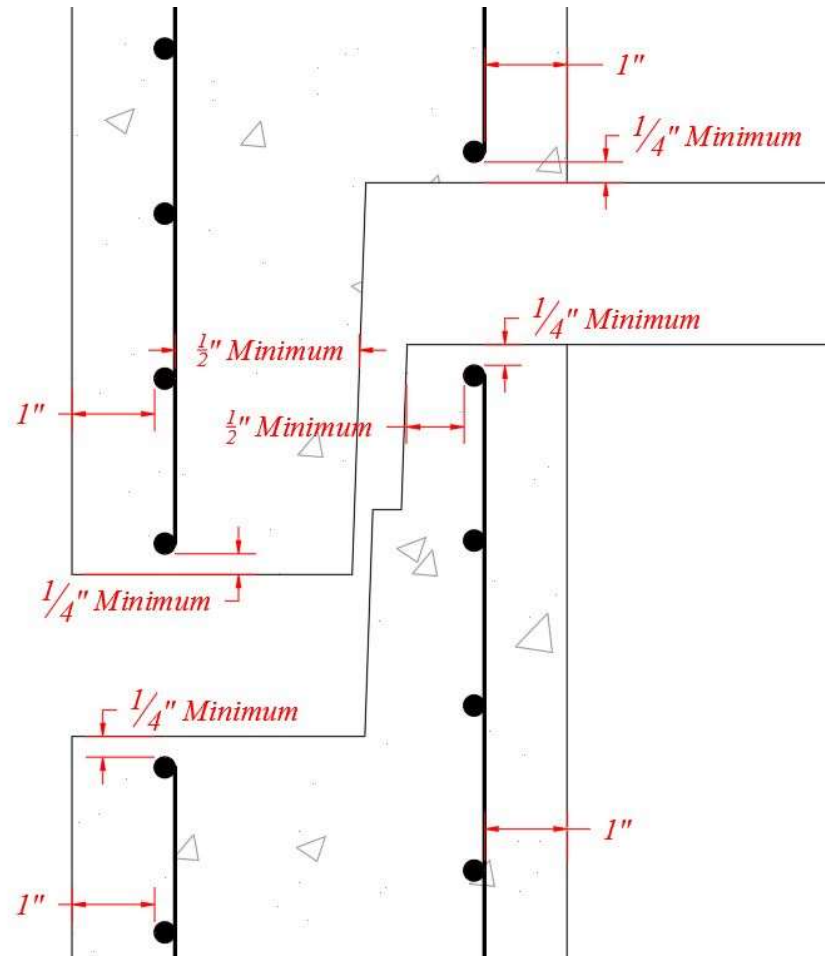

Figure 12.5.1-2





Section 8.3.2: Joint Reinforcement for Rubber Gasket Joints: 8.3.2.1 states:

- for pipe 12" and LARGER in diameter, the BELL ends shall contain circumferential reinforcement.
- If a separate cage is used, the cage shall extend into the pipe with the last circumferential wire at least 1" past the inside shoulder where the pipe barrel meets the bell of the joint.
- So, how long can your cage legs be before they are out of spec?



Section 8.3.2.2 states:

- Where bells require reinforcement, the maximum end cover on the last circumferential shall be 2”.



EXPANDED BELL WIRES:

- [C76 Section 8.3:](#)
- The end distances or cover on the end circumferential shall apply to any point on the circumference of the pipe or joint.
- When convoluted reinforcement is used, these distances and reinforcement areas shall be taken from the points on the convolutions closest to the end of the pipe section.

PERMISSIBLE VARIATIONS: Position of Reinforcement Section 12.5.1:

- If convoluted wire is used, the convoluted circumferential end wire may be at the end surface of the joint providing the alternate convolutions have at least 1" cover from the end surface of the joint.



- Convolute wire comes in 2, 3 or 4 convolute or “wiggly wires”. Sometimes called FLEX Wires or “S” wires.
- Only ONE weld on convolute wire is practical to have the wire expand and be uniformly concentric to the cage in the pipe wall.

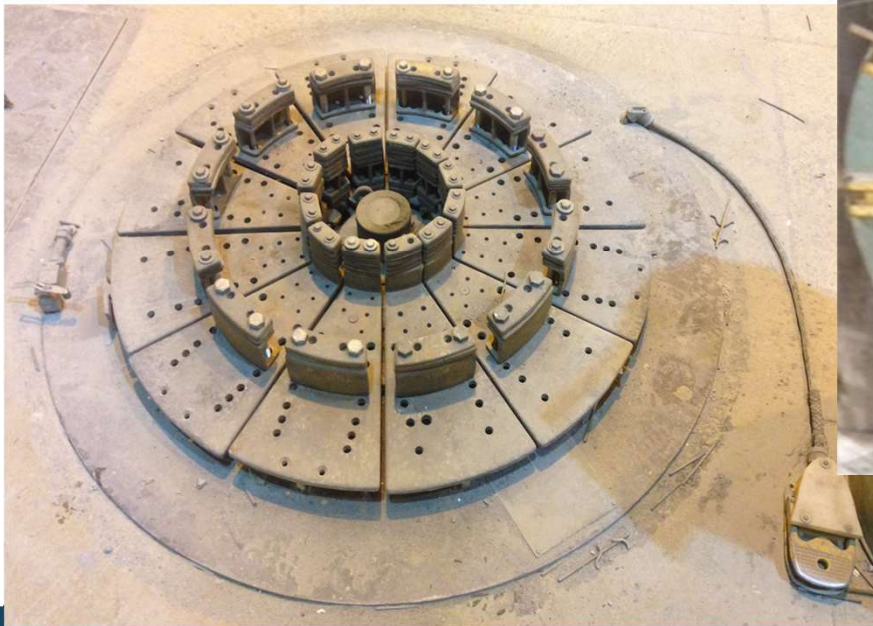



Cage Fabrication Do's:

-This cage details the proper location of the welds on the convolute wires of the cage. The welds are placed in the mid lap point of the cage.

This will allow proper expansion of the bell steel and the cage will stand straight as the steel is expanded more evenly.

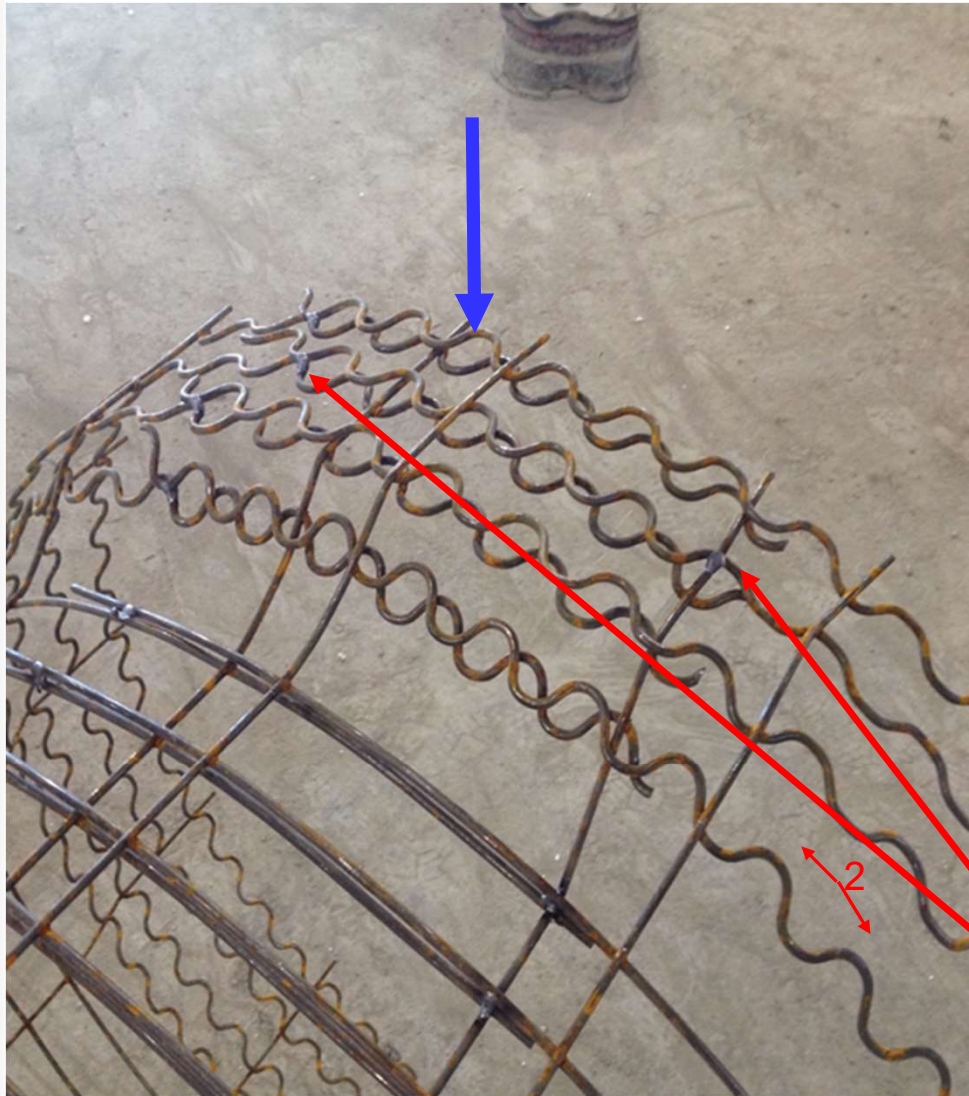

Cage Fabrication Do Not's:

-4 welds (one on each convoluted wire) should be placed in the lap area, ***not on the tails as shown.***

-Placing too many welds in one area of the bell will cause the steel to expand improperly.

-Notice how the second (2) wire is stretched more than the other three in the bell. This is due to the **extra weld** on the convoluted wire.

securus.

EXPANDABLE FABRIC STYLE DESIGNATION

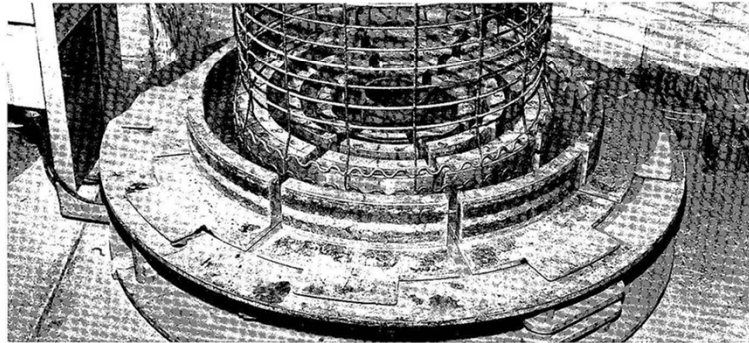
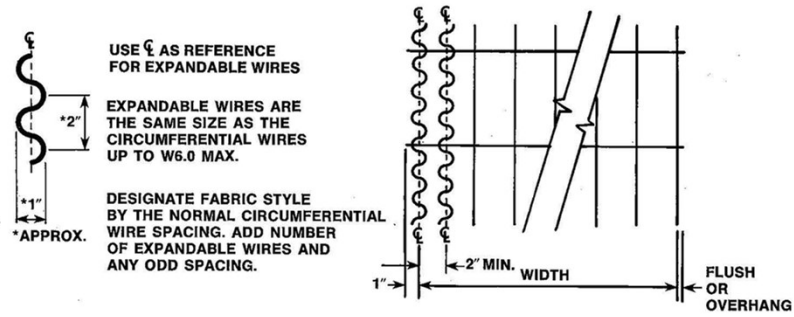

Floor-mounted expander units like the one above are helpful in large scale operations where more than one size pipe is being run simultaneously. With this simple expander unit, cages are flared to the

configuration desired. A side-mounted unit is advantageous where the welder who closes the cage also expands the bell reinforcement. (Photo courtesy of Hydro Conduit, Tulsa, Oklahoma.)



Back to the Specifications: Cover.....Concrete Cover

Concrete Cover definition: Per ACI Part 3, Section R7.7 (since there is **no ASTM C822** definition)

- Concrete Cover is a protection of reinforcement against weather and other effects
- Concrete Cover is measured from the CONCRETE SURFACE to the OUTERMOST SURFACE of the STEEL to which the COVER requirement applies.
- This is in compliance with all the previous specifications we just reviewed.
- **Proper cover in all areas: bell, haunch, barrel, shoulder, spigot.**
- **This is a major cause of pipe wall slab offs!**

- Some of our members may have references to **CLEAR COVER** or other terms that work for their operation. The specifications we are reviewing today do not make such reference, however, **CLEAR COVER** can best be illustrated as **the thickness of a block that you can slip between the wire cage and the core or jacket** (surface of the concrete).



REINFORCING INSPECTION WORKSHEET

Guideline: Document one cage at start of each shift and if any settings are changed.
Minimum required measurements shown.

Date									
Pipe Size									
Pipe Class									
Pipe Wall									
	Meas.	Spec.	Meas.	Spec.	Meas.	Spec.	Meas.	Spec.	
Dia. - 0°									
Dia. - 90°									
Horiz. Wire Spacing									
Horiz. Wire Dia.									
Area Check									
Vert. Wire Spacing									
Vert. Wire Dia.									
Area Check									
Length									
Lap									
*Bell Dia. - 0°									
*Bell Dia. - 90°									
Weld Check									
Spacer Check size & location									

Wire Machine Safety Stops
Initial if OK

	Monday Date _____	Tuesday Date _____	Wednesday Date _____	Thursday Date _____	Friday Date _____	Saturday Date _____
Machine 1						
Machine 2						
Machine 3						

* expande bell cages

Comments and Corrective Action:

What is Concrete Cover?



- ❑ Concrete cover is the smallest acceptable distance between the steel reinforcement and the outer or inner surface of the concrete. This distance varies from $\frac{3}{4}$ " to $2\frac{1}{2}$ " or more and is found in the ASTM specifications.

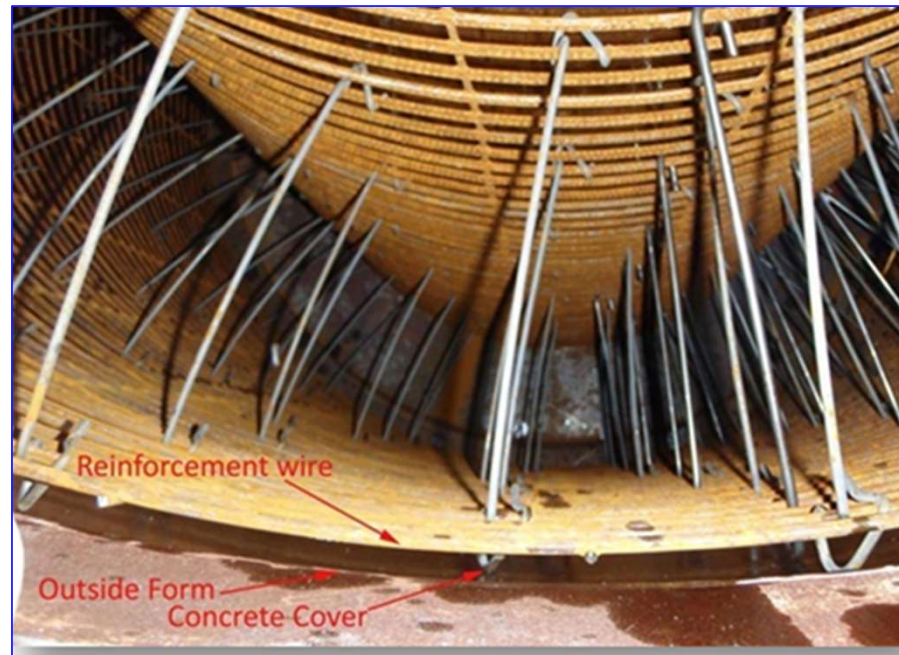



Why is Concrete Cover Important?



- ❑ Concrete: Cracking, Spalling, & Slabbing
- ❑ Steel: weakened from exposure to the environment (shadowing)
- ❑ Overall effect: lost of structural integrity



SHADOWING



SLABBING





Methods to Obtain Proper Concrete Cover



- ❑ Cage positioners
- ❑ Spacers **How do you pick the right spacer for different cages? One Line? How many Layers? How many forms?**
- ❑ Cutting and bending transverse wires - not recommended



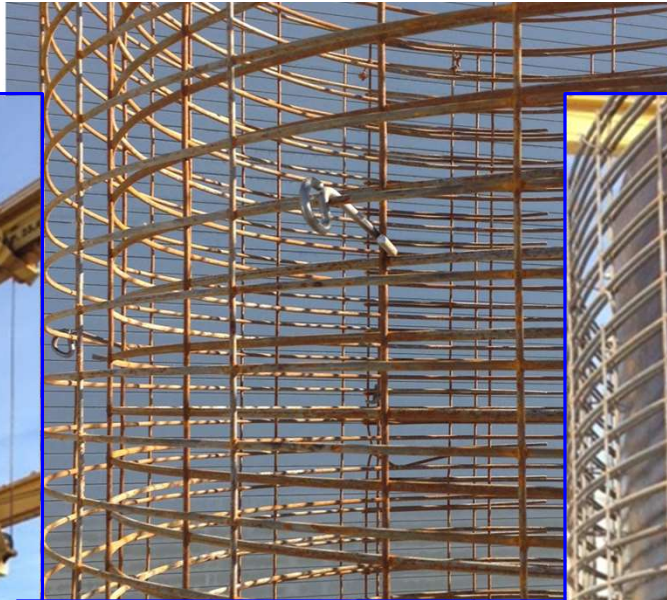

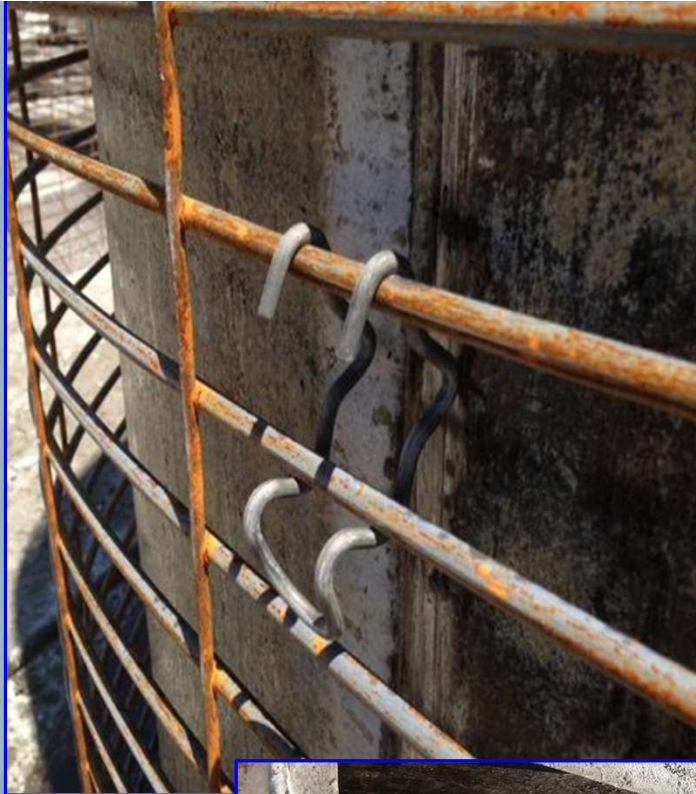



Methods to Obtain Proper Concrete Cover

- ❑ Places the steel reinforcement in the proper location required to meet structural design, during the casting operation.

Types of Reinforcement Spacers

- ❑ Single Cage



- ❑ Double Cage



Types of Reinforcement Spacers

Box Culvert



Heavy Duty





Plant Practices

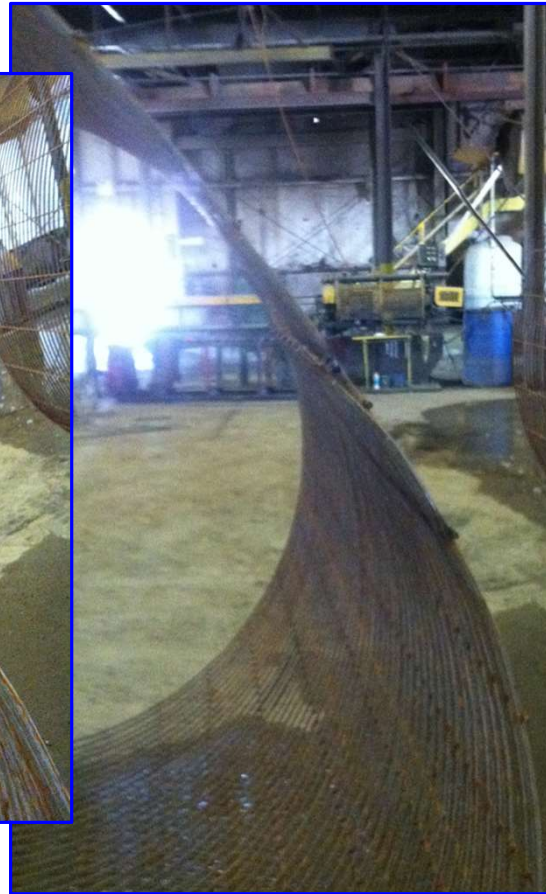
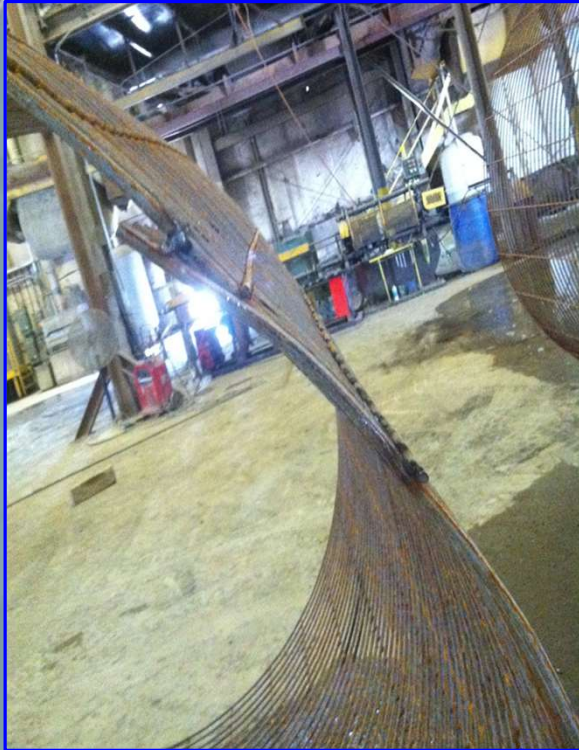

You can't put enough spacers on to save these cages!



Plant Practices

How Many Spacers are Required on a cage?

- The next 4 slides are commonly used practices for spacer placement. **This goes by your plant experience, even the suppliers have varying recommendations.**
- The manufacturing process, the stiffness of the cage and the size of the product all are determining factors in how many you should use.
- I can tell you that in large diameter pipe with relatively heavy wire manufactured by **the packerhead method**, we have found that three rows at around **32" maximum distance** in the circumferential direction is a good number to have a great finished product.
- In the information from our ACPA Associate sponsors, there is a great deal of information on the various types of products available to properly position our cages in the many different production methods that we use.



Spacers....Cage Positioners....Cage Mounted Types



STANDARD PLACEMENT OF SPACERS FOR SINGLE CAGE PIPE

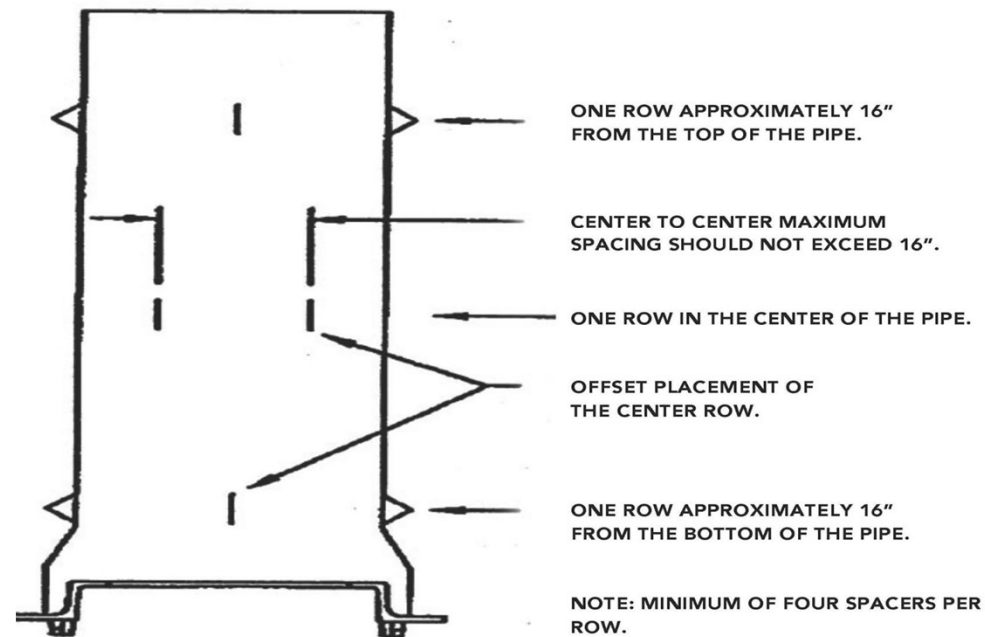



Spacers....Cage Positioners....Cage Mounted Types



MINIMUM PLACEMENT OF SPACERS FOR SINGLE CAGE PIPE

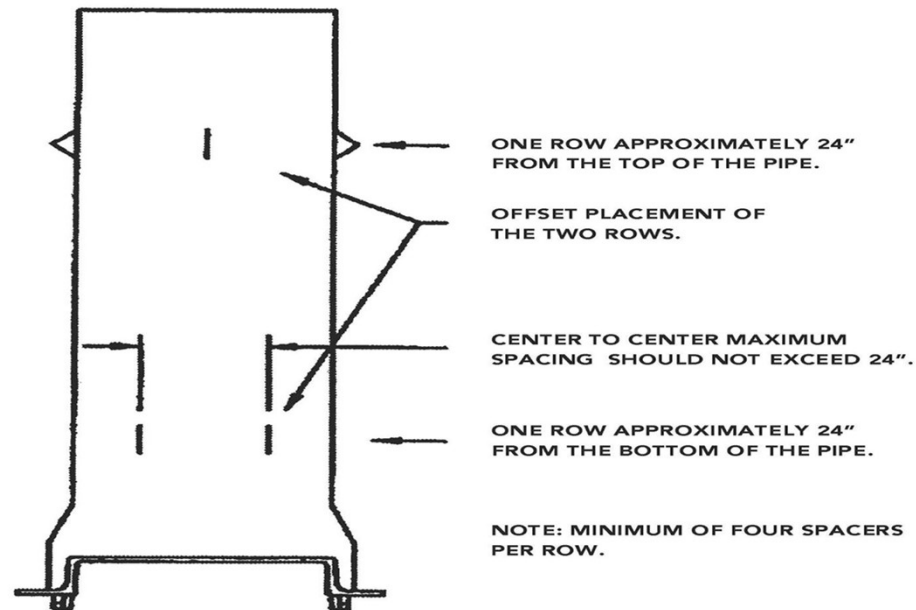

NOTE: THE MINIMUM PLACEMENT OF SPACERS FOR SINGLE CAGE PIPE MAY BE USED IF CAGE ROUNDNESS IS VERY GOOD. THREE EDGE BEARING TESTING MUST BE DONE TO INSURE THAT THE LOCATION OF THE STEEL REINFORCEMENT MEETS ASTM C-76 SPECIFICATION.

OCTOBER 1998



Spacers....Cage Positioners....Cage Mounted Types



STANDARD PLACEMENT OF SPACERS FOR DOUBLE CAGE PIPE

ONE ROW APPROXIMATELY 16" FROM THE TOP OF THE PIPE.

CENTER TO CENTER MAXIMUM SPACING SHOULD NOT EXCEED 16".

ONE ROW IN THE CENTER OF THE PIPE .

OFFSET PLACEMENT OF THE CENTER ROW.

ONE ROW APPROXIMATELY 16" FROM THE BOTTOM OF THE PIPE.

NOTE: MINIMUM OF FIVE SPACERS PER ROW.

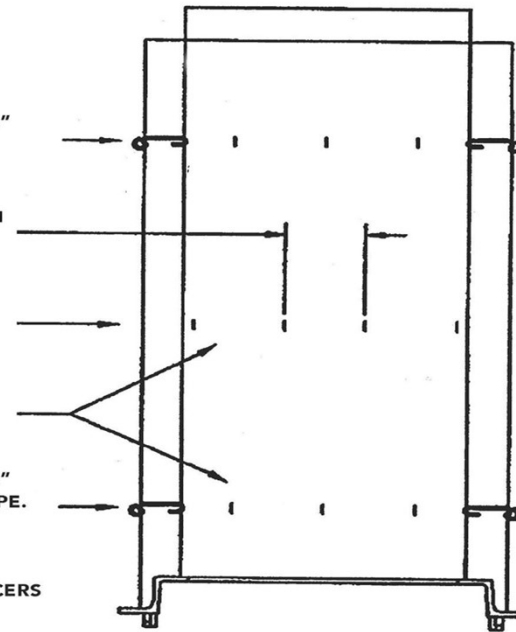



Spacers....Cage Positioners....Cage Mounted Types



MINIMUM PLACEMENT OF SPACERS FOR DOUBLE CAGE PIPE

ONE ROW APPROXIMATELY 24"
FROM THE TOP OF THE PIPE.

OFFSET PLACEMENT OF
THE TWO ROWS.

CENTER TO CENTER MAXIMUM
SPACING SHOULD NOT
EXCEED 24".

ONE ROW APPROXIMATELY 24"
FROM THE BOTTOM OF THE PIPE.

NOTE: MINIMUM OF FOUR
SPACERS PER ROW.

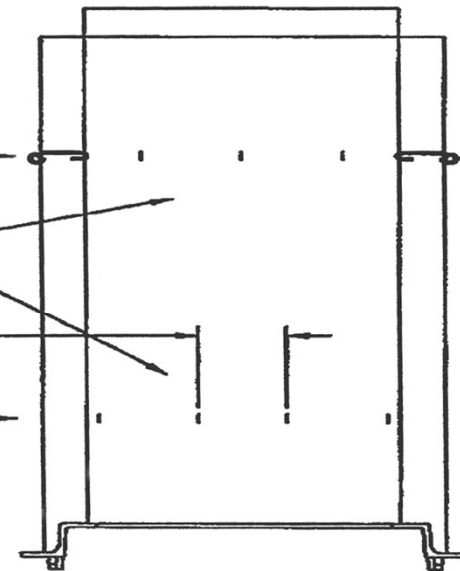

NOTE: THE MINIMUM PLACEMENT OF SPACERS FOR DOUBLE CAGE PIPE MAY BE USED IF CAGE ROUNDNESS IS VERY GOOD. THREE EDGE BEARING TESTING MUST BE DONE TO INSURE THAT THE LOCATION OF THE STEEL REINFORCEMENT MEETS ASTM C-76 SPECIFICATION.

OCTOBER 1998



Proper Pinning Practices

Plant Practices

- A properly pinned (spaced) cage is just as important as the dimensions of the cage itself.
- The spacing of the inner wire to the outer wire make a huge difference when pinning them together. This could change the length of spacer you would use.
- Check that the pins are tight to the cages and spaced evenly throughout the cage both horizontally and vertically. And they go **on a horizontal plane from inner to outer cage.**
- Make sure to notice then fix any bent legs in the cages as they can cause cage leaning problems when running pipe.



Plant Practices

- Cages should move freely in the packerhead form while oscillating and **running the bell packer**. If not, you can get cage twist or force the spacing pop the clips outside of the wall.
- Make sure to watch if the outer cage lifts up due to how you are pinning, as that can affect when running the bell packer.
- Cages must be cut to the correct height for your packerhead machine and **remember to account for when the bell packer lifts the cage during production of these pipe**.
- Cages with an expanded bell need extra support around the bottom of the cages because the pipe machine will twist the wire at this flared area. ..and they **MUST be concentric** to each other.



Plant Practices

Pinning or clipping or whatever your plant calls it; holding the cages together - using spacers to keep cover from the inside of the inner wall and outside of the outer wall. **You can only space off of the jacket on packerhead, so you must hold TWO LINE cages together, BOTH being spaced from the jacket!**

Make certain pins are tight and evenly spaced.

- Lighter steel cages like manholes or large barrel pipe like class 2, or class 3 cages **may require extra pins** as the packerhead machine has no problem flexing or deforming the cages because of the extra pack.
- Mesh made Class 4 wire **may need a little extra cover on the inner cages because of the lap seam** on our machine so we have to adjust our pins....watch your Section 12.5....Permissible Variations here!
- A cage clip should be pinned straight from the inner to the outer cages. A slight angle pin **should be angled up, if they are angled down it can lift the outer cage.**



Plant Practices

Choose the correct length of pin.

- 2" wire spacing on the inner wire spacing and 3" on the outer work well and next would use a 2" on the inner and 2" on the outer.
- 3" and 3" could change the clip size to maintain proper cover from the inner and outer wall.
- For small bore like 36" and 42", 4 rows of pins can be used
- For 48", 54", and 60", 5 rows of pins are usually used
- For 66" and 72", 7 or 8 rows of pins are used
- **REMEMBER** to make sure that you are not interpreting this information, but use it as guidelines to fit only what you or your equipment is capable of.



Standing Up Cages

Safety is ALWAYS the number one concern!!

- Cages are rolled in place in front of the pallet and stood up on a 45 degree angle from the pallet to catch the pallet and not roll off or interfere with others on the ground.
- Larger diameter cages require 2 or 3 people to stand them up safely if you don't use a machine to stand them.
- When standing cages make sure to keep your fingers on the outside of the cage as this fingers can easily be pinched in between cages and cause an injury.
- Be very cautious not to catch a glove on a longitudinal wire end as you lift the cage(s).
- Be very cautious not to wear rings when standing up cages to not catch them on the longitudinal wire end.



ASTM C-76 Section 12, Permissible Variations

12. Permissible Variations

12.1 *Internal Diameter*—The internal diameter of 12-in. through 24-in. pipe shall not vary by more than 2 % of the design diameter for 12-in. pipe and 1.5 % for 24-in. pipe with intermediate sizes variation being a linear scale between 2 % and 1.5 %. The internal diameter of sizes 27-in. and larger shall not vary by more than 1 % of the design diameter or $\pm\frac{3}{8}$ -in., whichever is greater. These diameter requirements are based on the average of four diameter measurements at a distance of 12 in. from the end of the bell or spigot of the pipe. Diameter verification shall be made on the number of pipe selected for test per Section 11.

12.2 *Wall Thickness*—The wall thickness shall not vary more than shown in the design or specified wall by more than $\pm 5\%$ or $\frac{3}{16}$ in., whichever is greater. A specified wall thickness more than required in the design is not cause for rejection. Pipe having localized variations in wall thickness exceeding those specified above shall be accepted if the three-edge-bearing strength and minimum steel cover requirements are met.

12.3 *Length of Two Opposite Sides*—Variations in the laying length of two opposite sides of the pipe shall not be more than $\frac{1}{4}$ in. for all sizes through 24-in. internal diameter, and not more than $\frac{1}{8}$ in./ft for all sizes larger with a maximum of $\frac{5}{8}$ in. in any length of pipe through 84-in. internal diameter, and a maximum of $\frac{3}{4}$ in. for 90-in. internal diameter or larger, except where beveled end pipe for laying on curves is specified by the owner.

12.4 *Length of Pipe*—The underrun in length of a section of pipe shall not be more than $\frac{1}{8}$ in./ft. with a maximum of $\frac{1}{2}$ in. in any length of pipe. Regardless of the underrun or overrun in any section of the pipe, the end cover requirements of Sections 8 and 12 shall apply.

12.5 *Position or Area of Reinforcement:*

12.5.1 *Position*—The maximum variation in the position of a line of circumferential reinforcement shall be $\pm 10\%$ of the wall thickness or $\pm\frac{1}{2}$ in., whichever is greater. Pipes having

variations in the position of a line of circumferential reinforcement exceeding those specified above shall be accepted if the three-edge-bearing strength requirements obtained on a representative specimen are met. In no case, however, shall the cover over the circumferential reinforcement be less than $\frac{1}{4}$ in. as measured to the end of the spigot or $\frac{1}{2}$ in. as measured to any other surface. The preceding minimum cover limitations do not apply to mating surfaces of nonrubber gasket joints or gasket grooves in rubber gasket joints. If convoluted reinforcement is used, the convoluted circumferential end wire may be at the end surface of the joint providing the alternate convolutions have at least 1 in. cover from the end surface of the joint.

12.5.2 *Area of Reinforcement*—Reinforcement will be considered as meeting the design requirements if the area, computed on the basis of nominal area of the wire or bars used, equals or exceeds the requirements of 7.1 or 7.2. Actual area of the reinforcing used may vary from the nominal area according to permissible variations of the standard specifications for the reinforcing. When inner cage and outer cage reinforcing is used, the inner cage nominal area may vary to the lower limit of 85 % of the elliptical nominal area and the outer cage nominal area may vary to the lower limit of 51 % of the elliptical nominal area provided that the total nominal area of the inner cage plus the outer cage shall not vary beyond the lower limit of 140 % of the elliptical nominal area.

Reference ASTM
C76 - 15a, Section 12.



Cage Machine example - We are making 24" C-76-III-B RCP

- In this example it's easy to see "why" we have the cage twist and failure of the cage and during testing.
- Using 9 longitudinal bars instead of 6 becomes approximately 9" spacing between bars. This is a more manageable and practical solution to this example.
- Since we would have more support of the cage by design we would be less likely to damage the cage during the Packerhead production process.



Reinforcing Cage Leg Lengths

- It is suggested to base the leg length at the pallet on the largest size of your aggregates. It is not recommended to exceed 1.5", as the cage becomes unsteady and is easier to topple, **especially for a cage machine cage**. Most keep it 1" or less on a cage machine cage but do what your company is successful at.
- Some will go to $\frac{3}{4}$ " OR $\frac{1}{2}$ " when using WWR mesh.
- **If the aggregates can't get between the cage and the pallet**, the finish of the bell will have a tendency to look and perform poorly.



Cover in the Spigot

- Cages in the spigot have little chance for success except when headers and ring formers are being used to keep the spigots to shape.**We cut our cages off right below the shoulder of the GROOVE or the Single Off-Set shoulder.**
- Even when headers are present the manufacturing of the cage diameter becomes more critical because there is not much room for error.
- Be careful as headers and ring formers could cause more issues than they actually solve.
- If you use fiberglass caps or sizing rings, it is critical that you lower those rings on to the joint evenly and concentrically or you will damage the joint pulling it out of shape.



Mesh Wire Rolling Machines

- A mesh roller feeds in prefabbed wire mesh layers to produce a diameter of the inner cage or outer cage, some using a computer program to account for lap and cover.
- Mesh must be **welded** together to very accurate round diameters. The diameter and circumference of the mesh cage must have precise dimensions.
- It is critical that you must make sure to check the circumference of each cage you are using to make cages from rolls of WWR.
- Reminder: When correcting or adjusting the overlap in a cage, the wire can be pounded out by laying down the cage, putting the seam up on, outside and between two parallel 2" x 4". Pound gently with a light sledge hammer to correct the measurement so the cage shape or wire ends do not affect the pipe in production.
 - You must **be careful** to not create a flat spot on the seams.



Mesh Wire Rolling Machines

- Mesh rollers can be used with varying strengths of prefabbed mesh, rolls or sheets, and even allow ability to produce a double layer wrapped steel cages as one continuous cage.
 - Pipe with **double wrapped** wire is difficult to produce on a Packerhead machine because of voids that can be left behind **and** between the wire.
- The leg lengths for the mesh roller cages can be less than the leg lengths on a cage machine cages.



ASTM Permissible Variations C-76 Section 12.5.1

Position of Reinforcement

The Maximum Variation In The Position of A Line Circumferential Reinforcement Should Be:
10% +/- of The Wall Thickness or 1/2", Which Ever Is Greater

Wall Thickness (In.)	10% +/-	For 1" of Cover	
		Min.	Max
1.75	0.175	-	-
1.875	0.188	-	-
2.00	0.200	-	-
2.50	0.250	-	-
2.625	0.263	-	-
2.75	0.275	-	-
3.00	0.300	-	-
3.25	0.325	0.675	1.325
3.50	0.350	0.650	1.350
3.75	0.375	0.625	1.375
4.00	0.400	0.600	1.400
4.25	0.425	0.575	1.425
4.50	0.450	0.550	1.450
4.75	0.475	0.525	1.475
5.00	0.500	0.500	1.500
5.25	0.525	0.500	1.525
5.50	0.550	0.500	1.550
5.75	0.575	0.500	1.575
6.00	0.600	0.500	1.600
6.25	0.625	0.500	1.625
6.50	0.650	0.500	1.650
6.75	0.675	0.500	1.675
7.00	0.700	0.500	1.700
7.25	0.725	0.500	1.725

Wall Thickness (In.)	10% +/-	For 1" of Cover	
		Min.	Max
7.50	0.750	0.500	1.750
7.75	0.775	0.500	1.775
8.00	0.800	0.500	1.800
8.25	0.825	0.500	1.825
8.50	0.850	0.500	1.850
8.75	0.875	0.500	1.875
9.00	0.900	0.500	1.900
9.25	0.925	0.500	1.925
9.50	0.950	0.500	1.950
9.75	0.975	0.500	1.975
10.00	1.000	0.500	2.000
10.25	1.025	0.500	2.025
10.50	1.050	0.500	2.050
10.75	1.075	0.500	2.075
11.00	1.100	0.500	2.100
11.25	1.125	0.500	2.125
11.75	1.175	0.500	2.175
12.00	1.200	0.500	2.200
12.75	1.275	0.500	2.275
13.00	1.300	0.500	2.300
13.75	1.375	0.500	2.375
14.00	1.400	0.500	2.400
15.00	1.500	0.500	2.500
15.75	1.575	0.500	2.575

* +/- 10% < 1/2"
 * For Standard Designs
 * Pipe With 1 Line of Reinforcing Is 35-50% of Wall Thickness From Inner Surface



Figure 12.5.1 – C-76 Permissible Variations – Location of Reinforcement

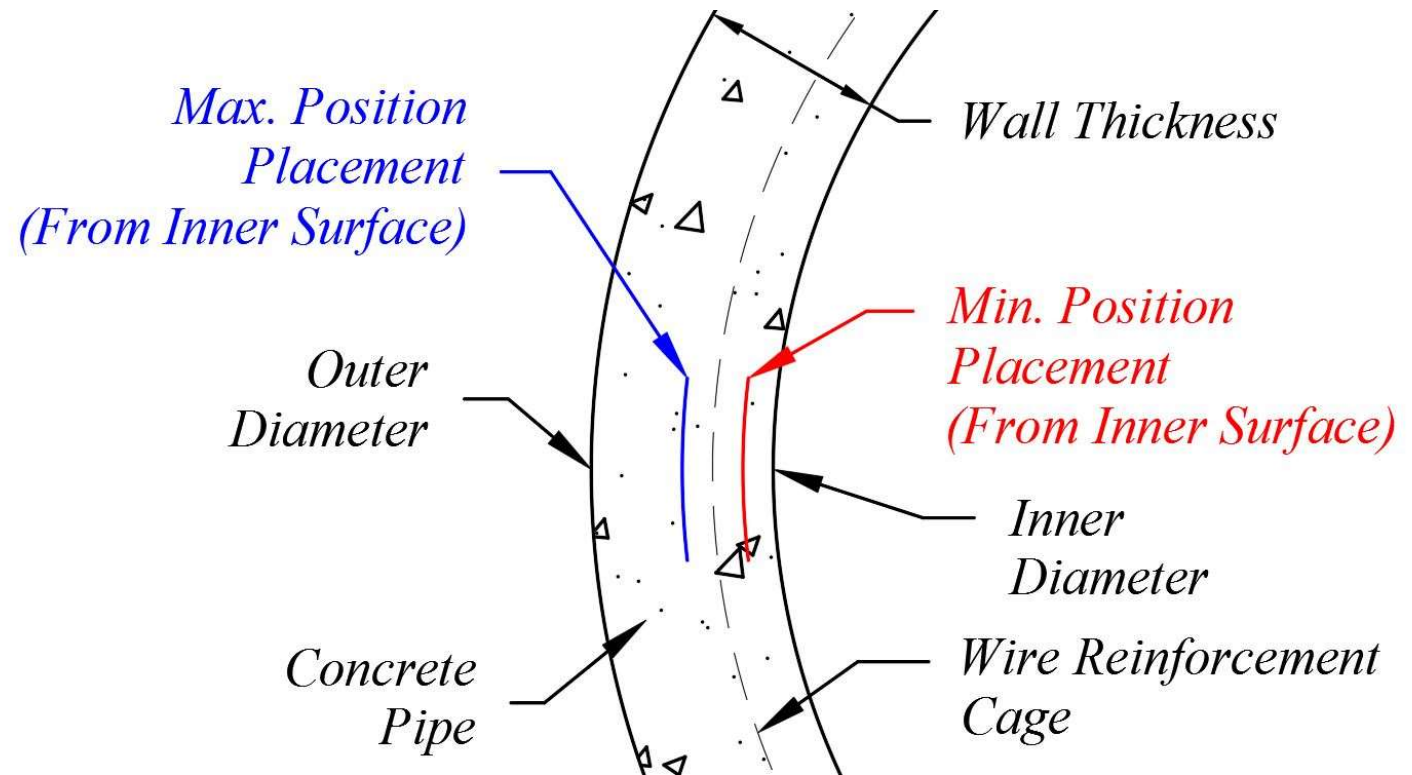



ASTM Permissible Variations C-76 Section 12.1

Internal Diameter

Pipe I.D. Size	Max % Vary +/-	Max In. Vary +/-	Max I.D.	Min. I.D.
12	2	0.24	12.24	11.76
15	1.875	0.281	15.281	14.718
18	1.75	0.315	18.315	17.685
21	1.625	0.341	21.341	20.658
24	1.5	0.36	24.36	23.64
27	1 *	*0.375	27.375	26.625
30	1 *	*0.375	30.375	29.625
36	1*	*0.375	36.375	35.625
42	1	0.42	42.42	41.58
48	1	0.48	48.48	47.52
54	1	0.54	54.54	53.46
60	1	0.60	60.6	59.40
66	1	0.66	66.66	65.34

Pipe I.D. Size	Max % Vary +/-	Max In. Vary +/-	Max I.D.	Min. I.D.
72	1	0.72	72.72	71.28
78	1	0.78	78.78	77.22
84	1	0.84	84.84	83.16
90	1	0.90	90.9	89.10
96	1	0.96	96.96	95.04
102	1	1.02	103.02	100.98
108	1	1.08	109.08	106.92
114	1	1.14	115.14	112.86
120	1	1.20	121.2	118.80
132	1	1.32	133.32	130.68
144	1	1.44	145.44	142.56
168	1	1.68	169.68	166.32

* * 0.375 > 1%

All Based On 4 Diameter Measurements
 * Must All Be In Different Locations
 *Minimum Reinforcing Steel Cover Must Be Met



Figure 12.1 – C-76 Permissible Variations – Internal Diameter

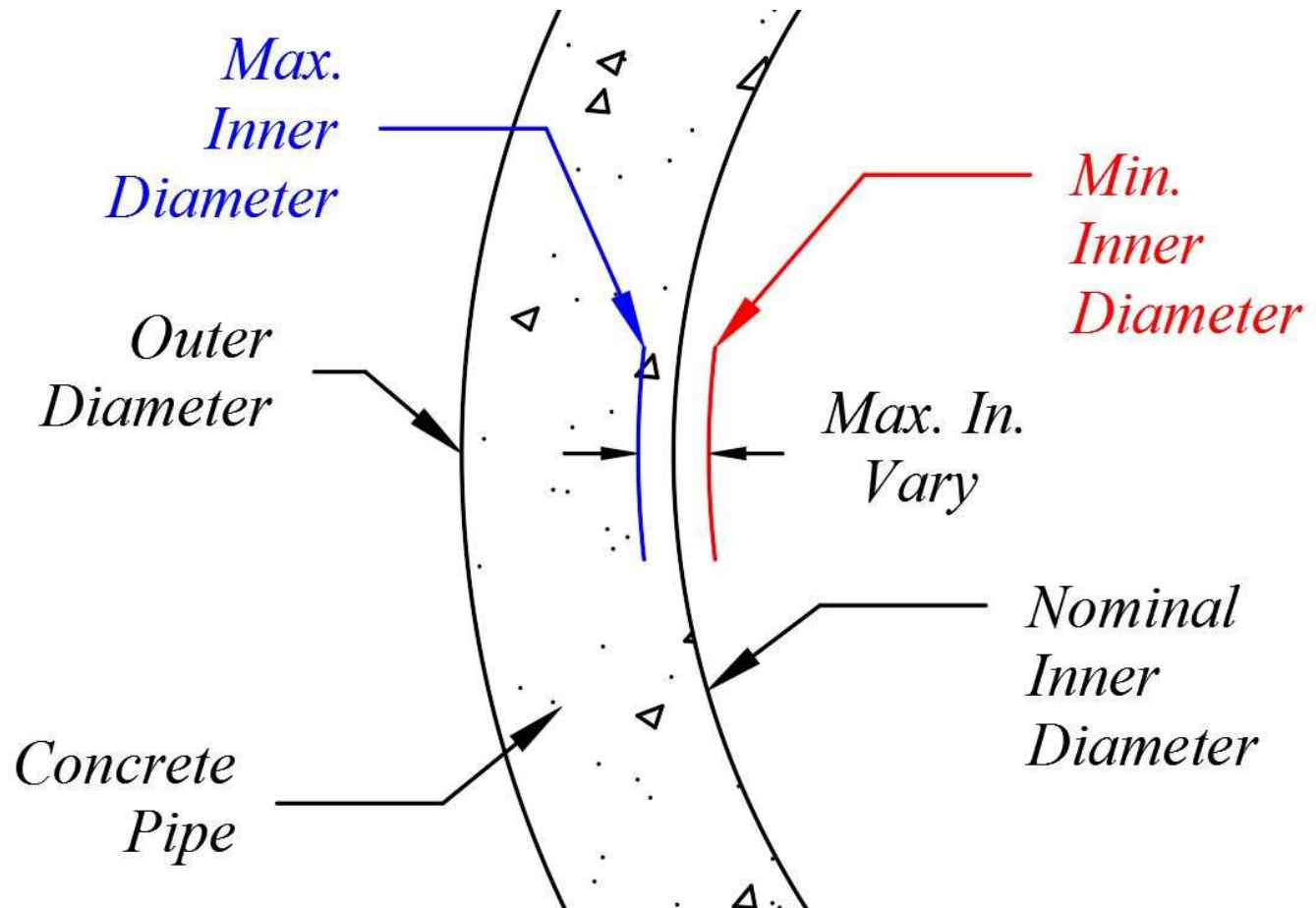



ASTM Permissible Variations C-76 Section 12.2

Wall Thickness

Pipe I.D. Size	Wall A				Wall B				Wall C			
	Wall thickness	Vary +/- %	Vary +/- Inch	Min. Wall Thickness	Wall thickness	Vary +/- %	Vary +/- Inch	Min. Wall Thickness	Wall thickness	Vary +/- %	Vary +/- Inch	Min. Wall Thickness
12	1.75	5*	* 0.1875	1.562	2.00	5*	* 0.1875	1.812	2.75	5*	* 0.1875	2.562
15	1.875	5*	* 0.1875	1.687	2.25	5*	* 0.1875	2.062	3.00	5*	* 0.1875	2.812
18	2.00	5*	* 0.1875	1.812	2.50	5*	* 0.1875	2.312	3.25	5*	* 0.1875	3.062
21	2.25	5*	* 0.1875	2.062	2.75	5*	* 0.1875	2.562	3.50	5*	* 0.1875	3.312
24	2.50	5*	* 0.1875	2.312	3.00	5*	* 0.1875	2.812	3.75	5	0.1875	3.563
27	2.625	5*	* 0.1875	2.437	3.25	5*	* 0.1875	3.062	4.00	5	0.2000	3.80
30	2.75	5*	* 0.1875	2.562	3.50	5*	* 0.1875	3.312	4.25	5	0.2125	4.038
36	3.00	5*	* 0.1875	2.812	4.00	5	0.20	3.80	4.75	5	0.2375	4.513
42	3.50	5*	* 0.1875	3.312	4.50	5	0.225	4.275	5.25	5	0.2625	4.988
48	4.00	5	0.200	3.80	5.00	5	0.25	4.75	5.75	5	0.2875	5.463
54	4.50	5	0.225	4.275	5.50	5	0.275	5.225	6.25	5	0.3125	5.938
60	5.00	5	0.250	4.75	6.00	5	0.30	5.70	6.75	5	0.3375	6.413
66	5.50	5	0.275	5.225	6.50	5	0.325	6.175	7.25	5	0.3625	6.888
72	6.00	5	0.300	5.70	7.00	5	0.35	6.65	7.75	5	0.3875	7.363
78	6.50	5	0.325	6.175	7.50	5	0.375	7.125	8.25	5	0.4125	7.838
84	7.00	5	0.350	6.65	8.00	5	0.40	7.60	8.75	5	0.4375	8.313
90	7.50	5	0.375	7.125	8.50	5	0.425	8.075	9.25	5	0.4625	8.788
96	8.00	5	0.400	7.60	9.00	5	0.45	8.55	9.75	5	0.4875	9.263
102	8.50	5	0.425	8.075	9.50	5	0.475	9.025	10.25	5	0.5125	9.738
108	9.00	5	0.450	8.550	10.00	5	0.50	9.50	10.75	5	0.5375	10.213
114	9.50	5	0.475	9.025	10.50	5	0.525	9.975	11.25	5	0.5625	10.688
120	10.00	5	0.500	9.50	11.00	5	0.55	10.45	11.75	5	0.5875	11.163
132	11.00	5	0.550	10.45	12.00	5	0.60	11.40	12.75	5	0.6375	12.113
144	12.00	5	0.600	11.40	13.00	5	0.65	12.35	13.75	5	0.6875	13.063
168	14.00	5	0.700	13.30	15.00	5	0.75	14.25	15.75	5	0.7875	14.963

*3/16" = 0.1875" > 5%

*36" & Up: Wall A = Wall In Feet; Convert To Inches

Wall B = Wall A Plus 1"

Wall C = Wall B Plus 3/4"

*Not Including Modified Bell Thickness Options (Many Acceptable Styles)

*A Specified Wall Thickness More Than Required In The Design Is Not Cause For Rejection

*Pipe Having Localized Variations In Wall Thickness Exceeding Those Specified Above Shall Be Accepted If The Three-Edge- Bearing Strength & Minimum Steel Requirements Are met

Figure 12.2 – C-76 Permissible Variations – Wall Thickness

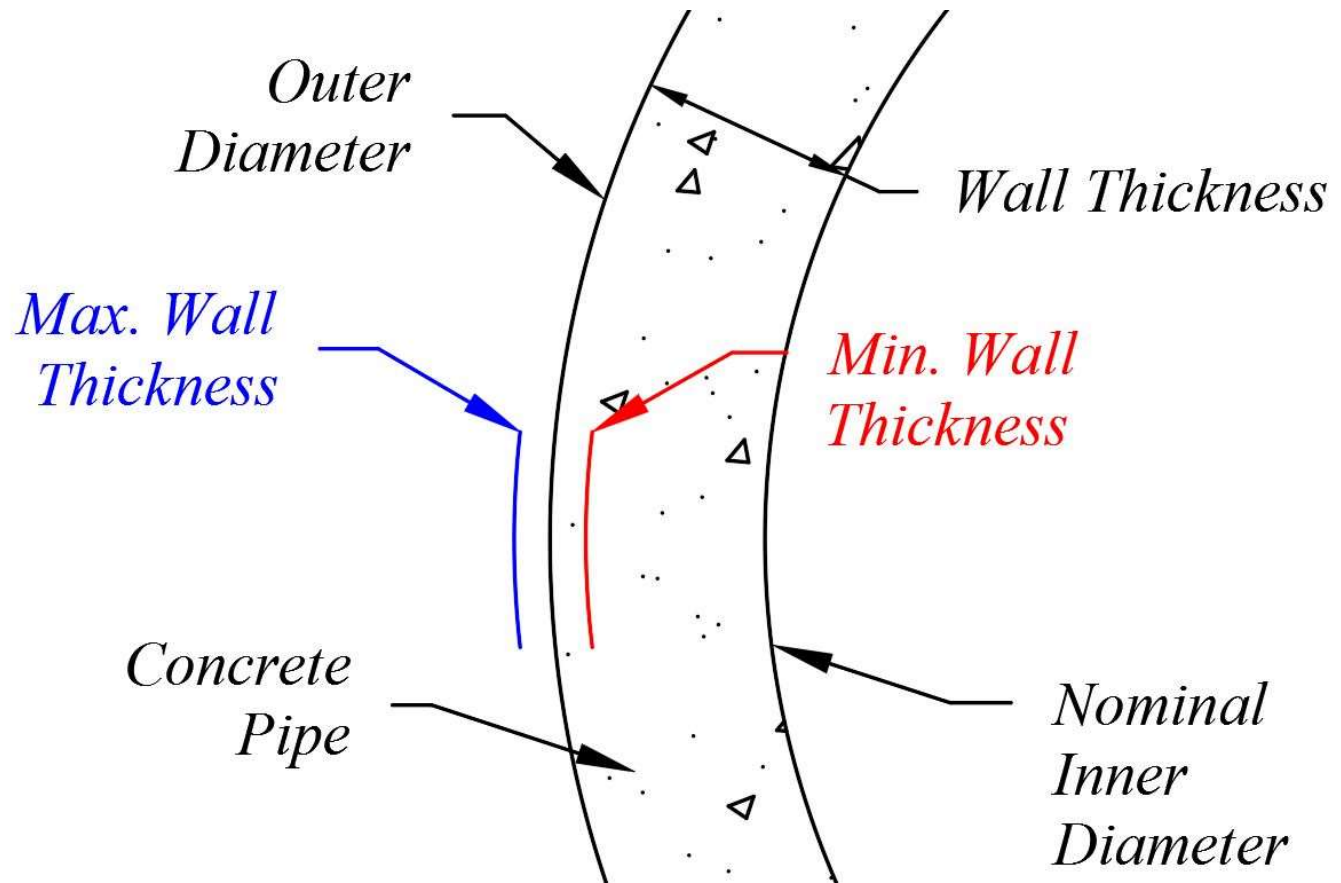



ASTM Permissible Variations C-76 Section 12.3	
Length Of Opposite Surfaces	
ID	Max Vary Lay Length (Inch)
12	*1/4"
15	*1/4"
18	*1/4"
21	*1/4"
24	*1/4"
27	**5/8"
30	**5/8"
36	**5/8"
42	**5/8"
48	**5/8"
54	**5/8"
60	**5/8"
66	**5/8"
72	**5/8"
78	**5/8"
84	**5/8"
90	***3/4"
96	***3/4"
102	***3/4"
108	***3/4"
114	***3/4"
120	***3/4"
126	***3/4"
132	***3/4"
144	***3/4"

*Variations In Lay Lengths of Two Opposite Surfaces Shall Not Be More Than 1/4" For All Sizes Up To 24" ID.

**Variations In Lay Lengths of Two Opposite Surfaces Shall Not Be More Than 1/8"/ft. (5/8" Max) For 27" Through 84"

***Variations In Lay Lengths of Two Opposite Surfaces Shall Not Be More Than 3/4" For Sizes 90" ID & Larger



Section 12.5.1 **Permissible Variations**; Position or Area of Reinforcement 12.5:

- In NO case...shall the cover over the circumferential reinforcement be less than $\frac{1}{4}$ " as measured to the END of the SPIGOT
- OR $\frac{1}{2}$ " as measured to any other surface. (of the spigot surface)
- These minimums covers DO NOT apply to the mating surfaces of non-rubber gasket joints OR gasket GROOVES in rubber gasket joints.







Section 8.2: Longitudinal Reinforcement:

- Commonly called: LONGITUDINAL WIRES or TRANSVERSE WIRES
- Each line of circumferential reinforcement shall be assembled into a cage that shall contain sufficient longitudinal bars or members, to maintain the reinforcement shape and in position within the form...
- No longer do we have a **minimum number** of these wires on our cages. Different types of pipe making processes still require certain numbers of these wires to make a good pipe.
- The **exposure of the ends** of the longitudinals, stirrups, or spacers that have been used to position the cages during the placement of the concrete **shall NOT BE CAUSE FOR REJECTION**. We have to point this out in EVERY PLANT TOUR we give.



Plant Practices

- All the topics we have previously discussed is information that all staff in your cage making crew needs to know.....NOBODY can remember this all and if they can, Mr. Murphy will have them someplace else, just when you need that experience the most.
- Keep records of all these options: **(for everyone's reference)**
- cage, height, diameter, area, preferred wire, class, ASTM Spec, wall thickness, spacer type and size, lap length, etc.....
- machine settings at end of each run
- results of QC checks for consistency verification
- **ELIMINATE ANY AND ALL GUESS WORK!**
- **This record keeping is a great way to train new employees. By their starting in cage production, they are trained in the importance of this part of the operation and it introduces them into the Plant work environment before working in the potentially more dangerous production areas.....for safety reasons.**



Plant practices

- What are some ways to know you are making a quality cage?
- After rolling your cage, check your length and diameter of the cages to see that you are in spec.
- When the cage makes it to the production floor, see how the cage **sets on the pallet**, inside the jacket and around the core. Make adjustments if needed.
- After the pipe is manufactured, **check the pipe** for any cracks, slabbing or protruding reinforcement.
- Finally, after the pipe has been cured, **check it again** for cracks, slabbing or protruding reinforcement.



Special Designs

C76 Section 7.2.1; Modified and Special Designs:

- If permitted by the owner the manufacturer may request approval by the owner of modified designs that differ from those in 7.1 (the Tables class 1-5);
- or special designs for sizes and loads beyond those shown in Tables 1-5,
- or special designs for pipe sizes that do not have steel reinforcement areas shown in Tables 1-5 of 7.1.

C76 Section 7.2.2:

- Such modified or special designsshall includeand the area, type, placement, number of LAYERS, and strength of the steel reinforcement.

C76 Section 7.2.3:

- The manufacturer shall submit to the owner **proof of the adequacy** of the proposed modified or special design.
- Such proof may comprise the submission of **certified three-edge-bearing test ALREADY MADE.....**

C76 Section 7.2.4:

- Such pipe must meet all of the test and performance requirements specified by the owner in accordance with Section 5.

Typically, these special designs can only be submitted by a registered engineer for the Project's owner's approval. **These are not in-plant production decisions!**



Special Designs: Shear Reinforcement





Special Designs



Date: 2/21/2012

Shop Drawing

Time: 9:39 AM

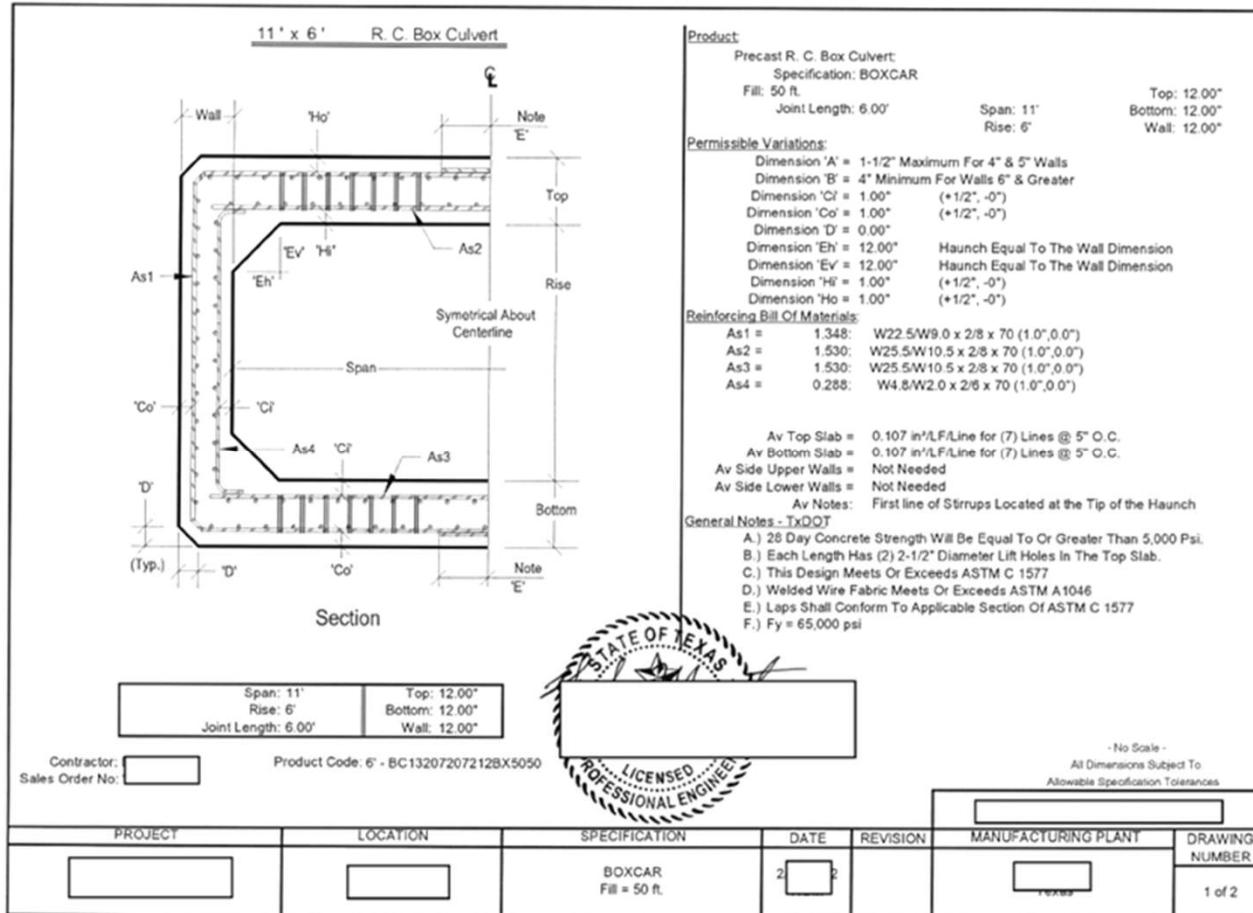



Typical Pipe Shop Drawing



Stirrup mats at **Crown & Invert**. Install the mat loops thru the inside cage toward the outer wall. The loops should be in contact with the inside circumferential reinforcement and tie mat to inside cage to keep in proper position.

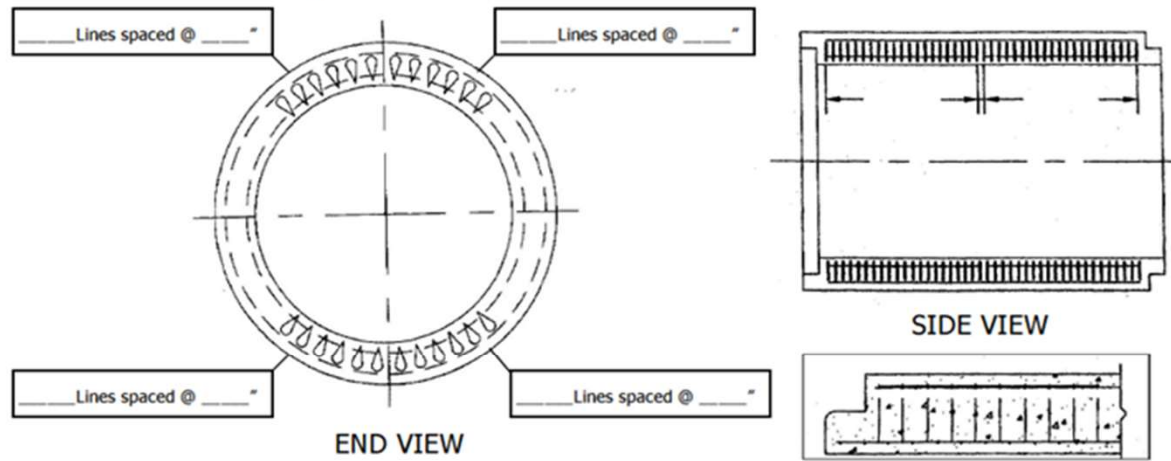

CUSTOMER:	
DIAMETER:	CLASS:
STIRRUP AREA:	IN SQ/FT OF LINE
TOTAL LINEAR FT:	LAY LENGTH:

APPROVED BY: _____

DATE: _____



Stirrup Mat Terminology



Engineered Wire Products, Inc. P.O. Box 313, Upper Sandusky, OH 43351 Phone: 800-842-8581 Fax: 419-294-1019 / 937-433-5326		DIA: _____ WALL: _____ CLASS: _____ CONCRETE: _____ COVER: _____ DESIGN SPEC: _____ PCS: _____ LENGTH: _____	
		'S'-STIRRUPS REQUIRED	
		CROWN	INVERT
		AREA REQ'D: _____	
		AMPLITUDE: _____	
		WIRE: _____	
		NODES: _____	
		LINES: _____	
		SPACING: _____	
ASSEMBLIES: _____			
CUSTOMER: _____		LOCATION: _____	
CONTACT: _____		PHONE: _____ FAX: _____	
PROJECT: _____			
DATE: _____		REP: _____	



Typical Box Shop Drawing



Stirrup mats installed at the tips of haunches. Install the mat loops thru the inside cage toward the outer wall and pin with Lock Rod.

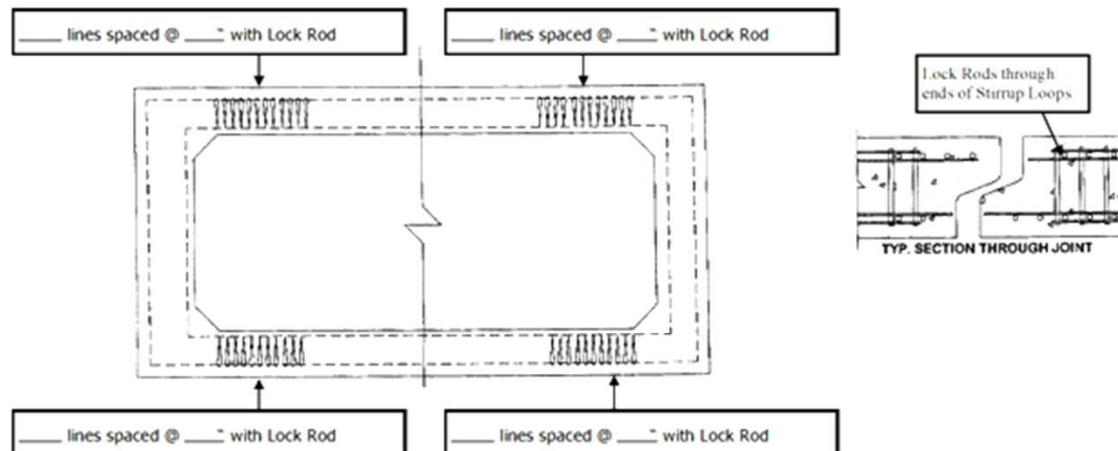

CUSTOMER: _____

BOX DIMENSIONS: _____

STIRRUP AREA: _____ IN SQ/FT OF LINE

TOTAL LINEAR FT: _____ LAY LENGTH: _____

APPROVED BY: _____

DATE: _____

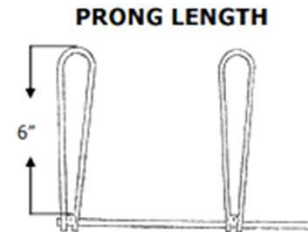



Standard "S"- Stirrups

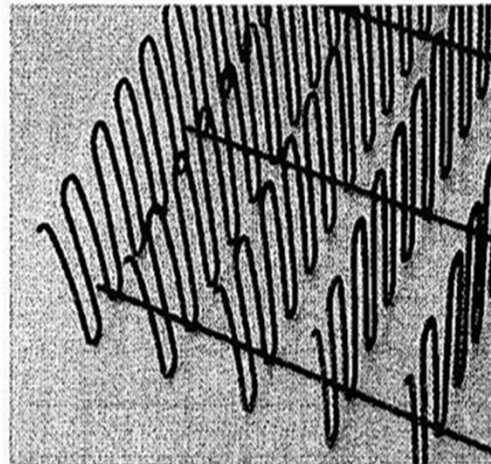

'S'-stirrup assembly

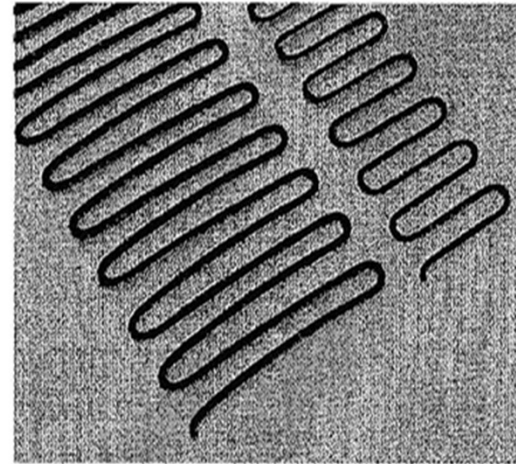

'S'-stirrups



Standard Stirrup Packaging





Box Culvert Reinforcement Product Practices



Plant Practices





Plant Practices





Plant Practices; **Our Machines:**

- We all have different cage **cutting, bending** and **assembling** equipment; some have **vintage** machinery that still performs as we need it to.
- Some have state of the art **computer controlled.**
- All Plant employees and supervisors need to understand the set-up and proficient operation of their particular equipment.
- We don't have the time required to get into those individual machine operation specifics today.





Plant Practices; Our Machines:





Plant Practices; Our Machines:





Plant Practices; Our Machines:





Plant Practices; Our Machines:





Our Machines:

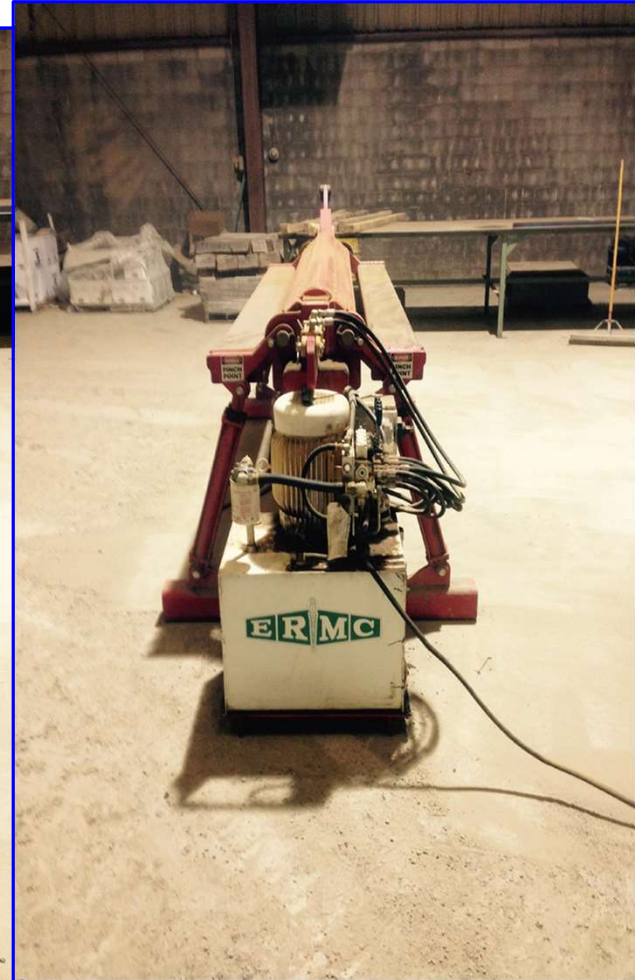



Plant Practices;
Our Machines:





Plant Practices; Our Machines:





BASIS of ACCEPTANCE

- C1433 & C1577 Section 5 state:
- Acceptability of the box sections produced in accordance with Section 7 shall be determined by the results of the **concrete compressive strength tests** described in Section 11, by the **material requirements** described in Section 6 and **by inspection of the finished box sections.**



- At the end of this Box Culvert presentation is a Copy of C1577 from the ASTM COMPASS website.
- This is allowed by permission of the ASTM C13-07 Sub Committee Chairman for ACPA educational purposes.
- **It is there to show the significant number of changes to the Standard in 2020.** C1433 will be voted on this year to have similar changes.
- **This is copyrighted material and can't be duplicated. It is for your reference.**
- You or your Company can get or may have a COMPASS account for further review of this ASTM Standard.



- Most importantly for this class;
Section 5.1 states:
- Acceptance on the **Basis of Materials Tests and Inspections....**
- Shall be determined by **the results...**
- By **inspection** of the **FINISHED** box sections
- INCLUDING amount and placement of **REINFORCEMENT** to determine its conformance with the accepted design and **its freedom from defects.**
- **Precisely what we are here for today!**



How Much of the ASTM Specification is about REINFORCING?.....MOST of it!

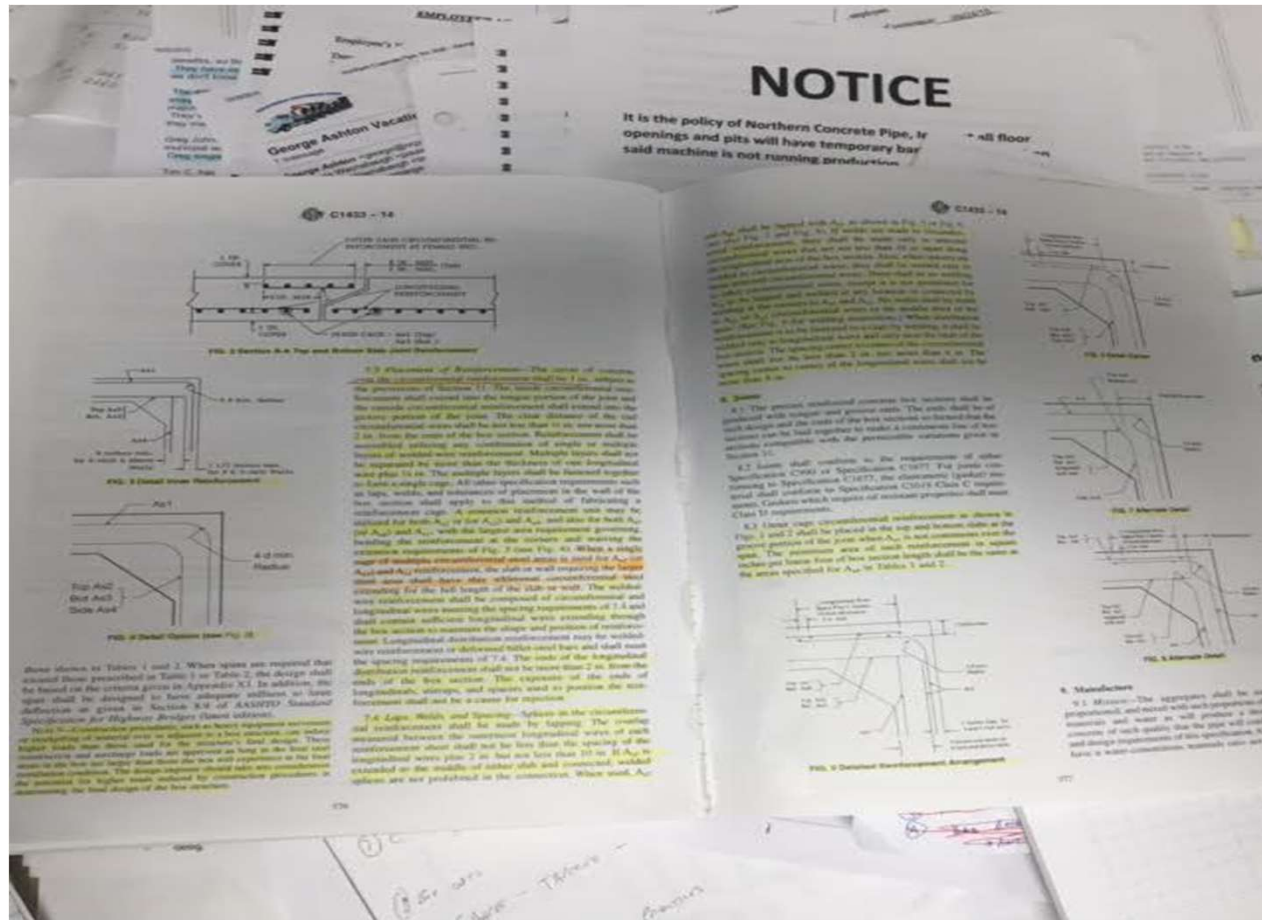



Plant Practices; Product Structural Design:





Plant Practices: Product Structural Design:





- Section 5.2 States:
- Box Sections shall be considered ready for acceptance when **they conform to the requirements of this specification.**
- What does this mean?
- It means there is **NO three-edge bearing test** or no other proof of design test like we have for our pipe products. **Everyone; the designer, the owner, the contractor, the public users and your employer are counting on us all** doing this product manufacturing as it is designed to be!
- **We are the only and FINAL assurance the box culvert is built right!**



- Our job is to make certain **our machinery and our people** do what is required by these specifications.
- If we fail to make certain this happens consistently in our Plants, it is certain our product could **fail to perform** as designed.



Area of Reinforcement; Tables:

-Actual area of the reinforcing used may vary from the nominal area according to PERMISSIBLE VARIATIONS or the standard specifications for the reinforcing.
- Nominal Area Definition: (not stated in ASTM C822): **Theoretical area required.**



Table 1: C1433; Design Requirements; page one:

ACPA C1433 – 14

TABLE 1 Design Requirements for Precast Concrete Box Sections Under Earth Dead and HS20 Live Load Conditions

NOTE 1—Design earth covers and reinforcement areas are based on the weight of a column of earth over the width of the box section as defined in Appendix X1.

NOTE 2—Concrete design strength 5000 psi.

NOTE 3—The design earth cover indicated is the height of fill above the top of the box section. Design requirements are based on the material and soil properties, loading data, and typical section as included in Appendix X1. For alternative or special designs, see 7.2.

NOTE 4—Design steel area in square inches per linear foot of box section at those locations which are indicated on the typical section included in Fig. 1.

NOTE 5—The top section designation, for example, 3 ft by 2 ft by 4 in. indicates (interior horizontal span in feet) by (interior vertical rise in feet) by (wall and slab thickness in inches).

NOTE 6—In accordance with the acceptance criteria in 7.2, the manufacturer may interpolate the steel area requirements for fill heights between noted increments or may submit independent designs.

3 ft by 2 ft by 4 in.													
Span ft	Rise ft	Top in.	Bottom in.	Side in.	Haunch in.	Design Earth Cover ft	Circumferential Reinforcement Areas, in. ² /ft						"M," in.
							A _{s1}	A _{s2}	A _{s3}	A _{s4}	A _{s5}	A _{s7}	
3	2	7	6	4	4	0-2	0.17	0.38	0.21	0.10			
3	2	4	4	4	4	2<3	0.13	0.21	0.21	0.10	0.19	0.17	0.14
3	2	4	4	4	4	3-5	0.10	0.10	0.10	0.10			
3	2	4	4	4	4	10	0.10	0.10	0.10	0.10			
3	2	4	4	4	4	15	0.10	0.14	0.14	0.10			
3	2	4	4	4	4	20	0.11	0.18	0.19	0.10			
3	2	4	4	4	4	25	0.14	0.23	0.23	0.10			
3	2	4	4	4	4	30	0.17	0.27	0.27	0.10			
3	2	4	4	4	4	35	0.20	0.31	0.31	0.10			
3 ft by 3 ft by 4 in.													
Span ft	Rise ft	Top in.	Bottom in.	Side in.	Haunch in.	Design Earth Cover ft	Circumferential Reinforcement Areas, in. ² /ft						"M," in.
							A _{s1}	A _{s2}	A _{s3}	A _{s4}	A _{s5}	A _{s7}	
3	3	7	6	4	4	0-2	0.17	0.40	0.23	0.10	0.20	0.17	0.14
3	3	4	4	4	4	2<3	0.10	0.25	0.25	0.10			
3	3	4	4	4	4	3-5	0.10	0.10	0.11	0.10			
3	3	4	4	4	4	10	0.10	0.11	0.11	0.10			
3	3	4	4	4	4	15	0.10	0.15	0.16	0.10			
3	3	4	4	4	4	20	0.10	0.20	0.20	0.10			
3	3	4	4	4	4	25	0.10	0.24	0.25	0.10			
3	3	4	4	4	4	30	0.12	0.29	0.29	0.10			
3	3	4	4	4	4	35	0.14	0.33	0.34	0.10			
4 ft by 2 ft by 5 in.													
Span ft	Rise ft	Top in.	Bottom in.	Side in.	Haunch in.	Design Earth Cover ft	Circumferential Reinforcement Areas, in. ² /ft						"M," in.
							A _{s1}	A _{s2}	A _{s3}	A _{s4}	A _{s5}	A _{s7}	
4	2	7.5	6	5	5	0-2	0.18	0.40	0.20	0.12	0.20	0.18	0.14
4	2	5	5	5	5	2<3	0.21	0.23	0.20	0.12			
4	2	5	5	5	5	3-5	0.12	0.12	0.12	0.12			
4	2	5	5	5	5	10	0.12	0.12	0.13	0.12			
4	2	5	5	5	5	15	0.14	0.17	0.18	0.12			
4	2	5	5	5	5	20	0.19	0.23	0.23	0.12			
4	2	5	5	5	5	25	0.23	0.28	0.28	0.12			
4	2	5	5	5	5	30	0.28	0.33	0.33	0.12			
4	2	5	5	5	5	35	0.33	0.38	0.39	0.12			
4 ft by 3 ft by 5 in.													
Span ft	Rise ft	Top in.	Bottom in.	Side in.	Haunch in.	Design Earth Cover ft	Circumferential Reinforcement Areas, in. ² /ft						"M," in.
							A _{s1}	A _{s2}	A _{s3}	A _{s4}	A _{s5}	A _{s7}	
4	3	7.5	6	5	5	0-2	0.18	0.45	0.23	0.12	0.22	0.18	0.14
4	3	5	5	5	5	2<3	0.16	0.28	0.25	0.12			
4	3	5	5	5	5	3-5	0.12	0.12	0.13	0.12			
4	3	5	5	5	5	10	0.12	0.14	0.15	0.12			
4	3	5	5	5	5	15	0.12	0.20	0.20	0.12			
4	3	5	5	5	5	20	0.14	0.26	0.26	0.12			
4	3	5	5	5	5	25	0.17	0.32	0.32	0.12			
4	3	5	5	5	5	30	0.21	0.38	0.38	0.12			
4	3	5	5	5	5	35	0.25	0.44	0.44	0.12			
4 ft by 4 ft by 5 in.													
Span ft	Rise ft	Top in.	Bottom in.	Side in.	Haunch in.	Design Earth Cover ft	Circumferential Reinforcement Areas, in. ² /ft						"M," in.
							A _{s1}	A _{s2}	A _{s3}	A _{s4}	A _{s5}	A _{s7}	
4	4	7.5	6	5	5	0-2	0.18	0.47	0.25	0.12	0.23	0.18	0.14
4	4	5	5	5	5	2<3	0.13	0.31	0.28	0.12			



- These **Tables**, **regardless of the shape** of the box culvert indicate:
- **Box Dimensions: Span, Rise and Haunch**
- **Wall Thickness: Top, Bottom and Sides**
- Concrete Strength
- Design Earth Cover
- Earth Load (Cover) and Live Load Conditions
- **Cage Combinations allowed, using the specified Table areas or the options allowed by the footnotes.**
- **Design Steel Areas: in square inches per linear foot of box section**
- **5** of these 7 criteria are important to our cage making practices.



Cage Shape; Part #1

- The numbered “**Figure (Fig.)**” are details that give us some allowable shape options as long as we meet all guidelines for each detail type.
- We have choices; use **Table** (ex: **Table 1 in C1433**) designs with these “Figure” options for cage configuration. **Who decides that in your Plant...every job may have different requirements.**
- Remember; these options are very typical to all our different box culvert shapes.
- We can spend more time on these if time permits at the end of the class. There is a huge amount of experience we can share here in this room.



Plant Practices:

- Cage **SHAPE** is our **#1 in-plant cage production problem**
- Our Associates are ready to help your Plant with problems; please use the opportunities the Contacts list in the Appendix gives you.

Trying to promote some questions here!:

- **What can put a cage out of shape? This gives us the most problems:**
 - Mesh Roller improperly adjusted.....too tight.....too open
 - Too few transverse (longitudinal) wires
 - What dimension are we supposed to be at?
 - Do you have tapered forms? Measure top and bottom of cage
 - All legs the same length to prevent wobble
 - Too hot of welder settings distorting the cage
 - Dropping the WWF mat from the roller
 - Dragging the cage or WWF mat can bend the legs
 - Tipping cages can distort the bell or spigot dependent on which way your plant has as the bottom of the cage
 - Improper handling jigs or rigs not pulling uniformly on the cage.

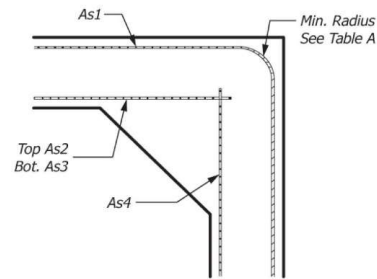

FIG. 3 Detail Inner Reinforcement

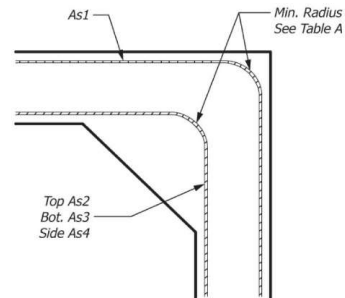

FIG. 4 Detail Option (see Fig. 3)

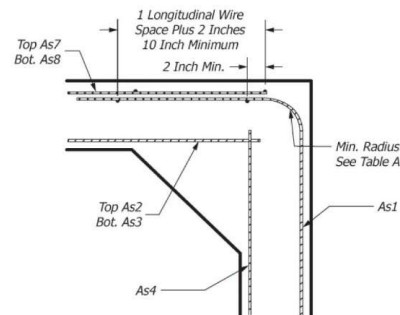

FIG. 5 Detailed Reinforcement Arrangement

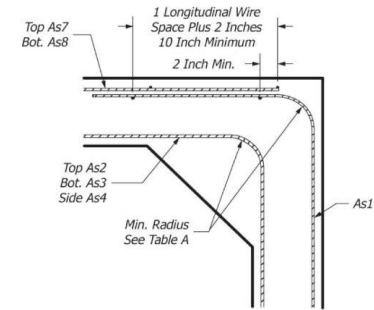

FIG. 6 Detail Option

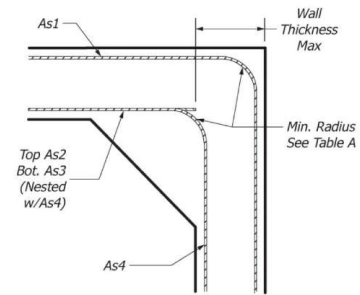

FIG. 7 Alternate Detail

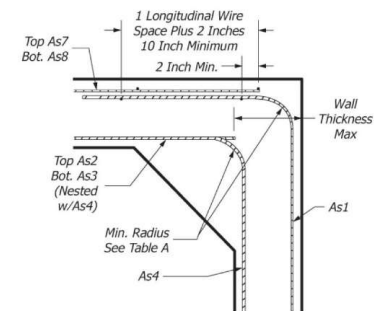

FIG. 8 Alternate Detail (see Fig. 5)

- Are you making the most cost effective and efficiency effective cage design for your Companies needs?

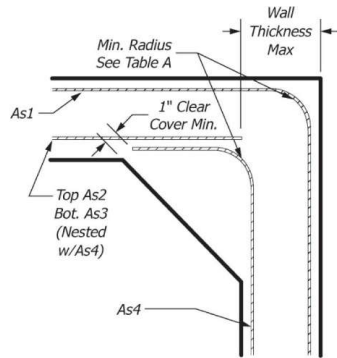

FIG. 9 Alternate Detail

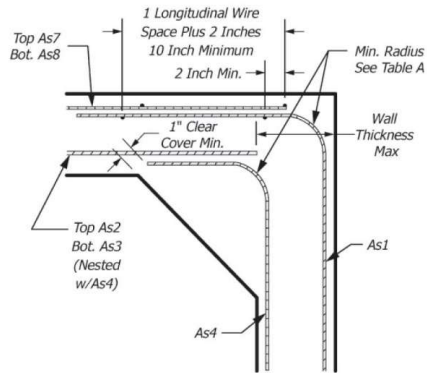

FIG. 10 Alternate Detail

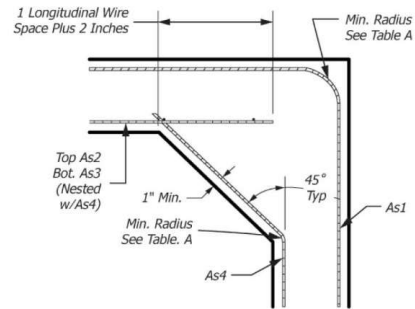

FIG. 11 Alternate Detail

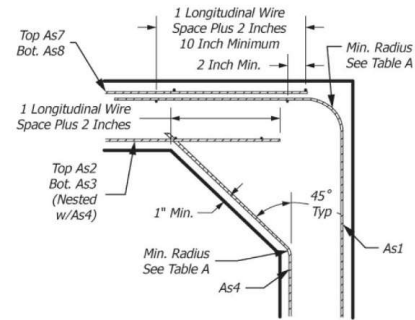

FIG. 12 Alternate Detail

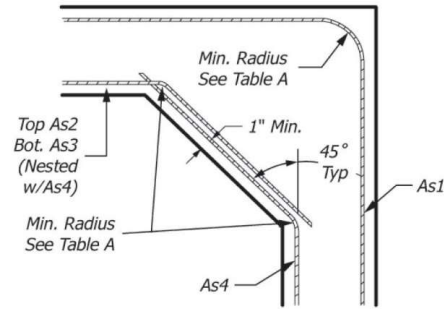

FIG. 13 Alternate Detail

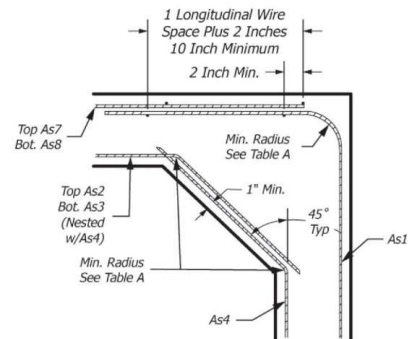

FIG. 14 Alternate Detail



- **NEW: Mitered Inner Wire in Haunches as many Producers HAVE Been doing.**
- If the joint configuration requires or at the option of the manufacturer, **Fig. 9** and **Fig. 10** provide a permissible **mitered** INNER cage detail.
- When selecting this option, the **minimum clear cover** for the welded wire fabric over the face of the haunches **shall be 1 in.**
- **It is permissible to just shape, remove and replace the section of cage that interferes with the shape of the joint or miter the wire bars in the joints if necessary, to conform to the shape of the joint formers provided proper laps and radius requirements are adhered to.**
- In no case shall the maximum **cover of the reinforcing across the face of the haunches be more than 3 in.**



Cage Configuration: With a little help from our Friends!
Thanks to the engineering staff at INSTEEL for putting these next few slides together for us! There are 16 total slides from INSTEEL in the Appendix #2 with very good **PRECAST PROMOTIONAL** Information.



WWR Advantages

- Numerous mat combinations to suit precaster placement preference without compromising structural force profiles defined by engineer.

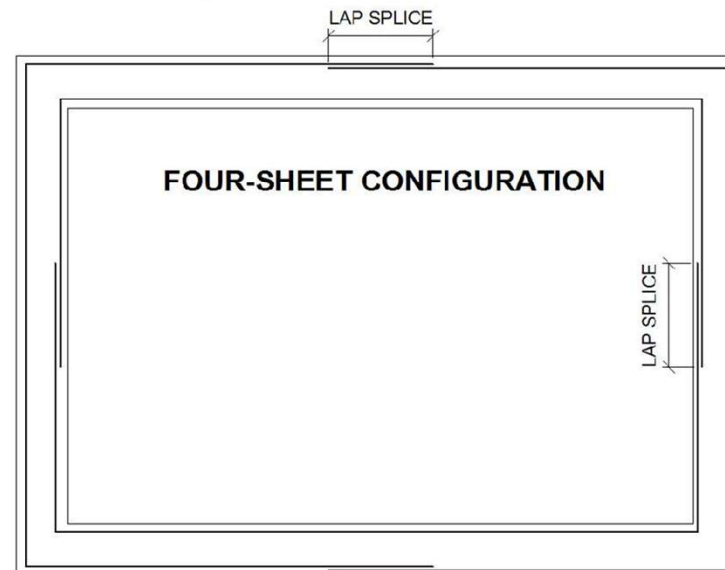



WWR Advantages

- Numerous mat combinations to suit precaster placement preference without compromising structural force profiles defined by engineer.

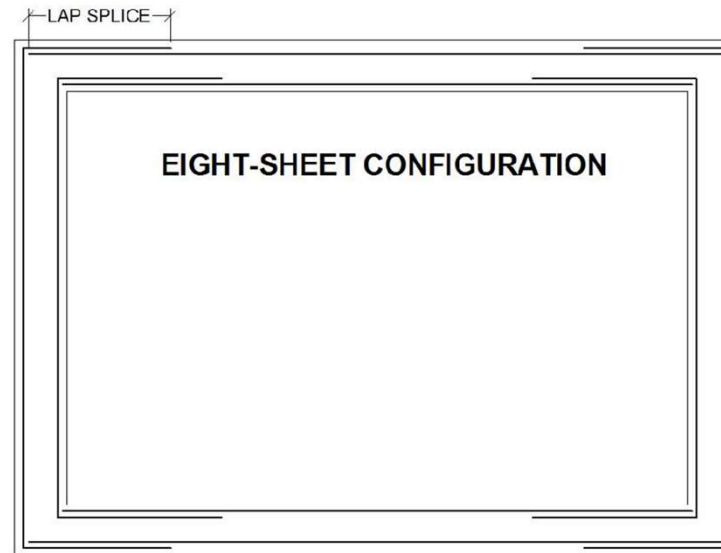

WWR Advantages

- Numerous mat combinations to suit precaster placement preference without compromising structural force profiles defined by engineer.

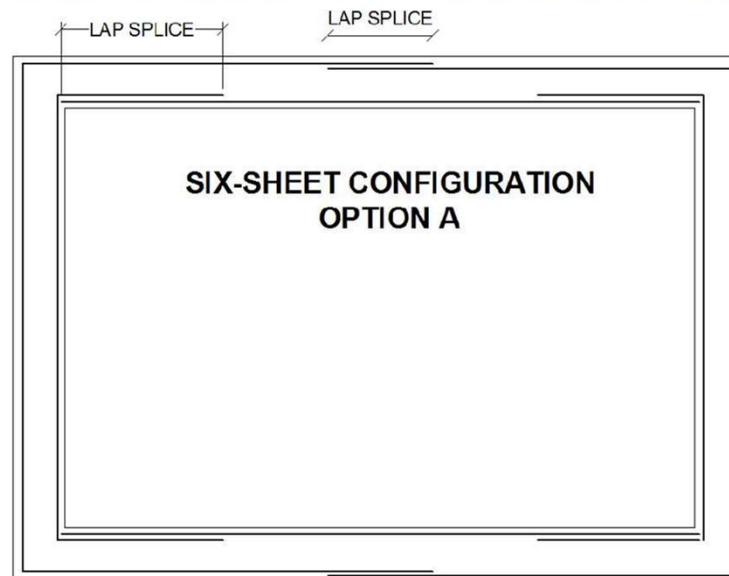

WWR Advantages

- Numerous mat combinations to suit precaster placement preference without compromising structural force profiles defined by engineer.

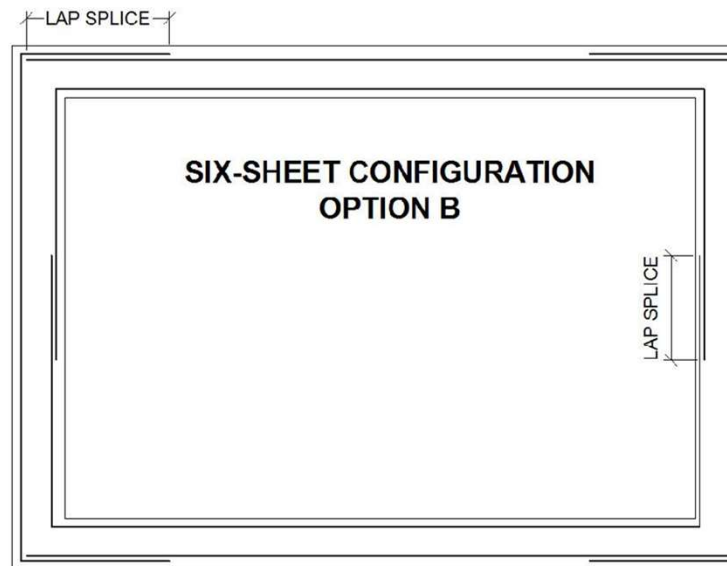



WWR Advantages

- Numerous mat combinations to suit precaster placement preference without compromising structural force profiles defined by engineer.

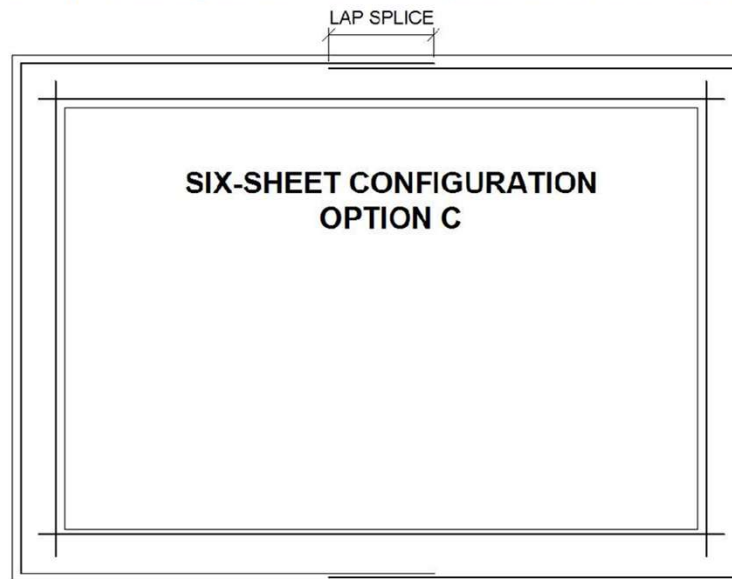



Table 1: C1433; Design Requirements; page one:

C1433 – 14

TABLE 1 Design Requirements for Precast Concrete Box Sections Under Earth Dead and HS20 Live Load Conditions

NOTE 1—Design earth covers and reinforcement areas are based on the weight of a column of earth over the width of the box section as defined in Appendix X1.

NOTE 2—Concrete design strength 5000 psi.

NOTE 3—The design earth cover indicated is the height of fill above the top of the box section. Design requirements are based on the material and soil properties, loading data, and typical section as included in Appendix X1. For alternative or special designs, see 7.2.

NOTE 4—Design steel area in square inches per linear foot of box section at those locations which are indicated on the typical section included in Fig. 1.

NOTE 5—The top section designation, for example, 3 ft by 2 ft by 4 in. indicates (interior horizontal span in feet) by (interior vertical rise in feet) by (wall and slab thickness in inches).

NOTE 6—In accordance with the acceptance criteria in 7.2, the manufacturer may interpolate the steel area requirements for fill heights between noted increments or may submit independent designs.

3 ft by 2 ft by 4 in.														
Span ft	Rise ft	Top in.	Bottom in.	Side in.	Haunch in.	Design Earth Cover ft	Circumferential Reinforcement Areas, in. ² /ft							"M," in.
							A ₂₁	A ₂₂	A ₂₃	A ₂₄	A ₂₅	A ₂₇	A ₂₈	
3	2	7	6	4	4	0-2	0.17	0.38	0.21	0.10				
3	2	4	4	4	4	2-3	0.13	0.21	0.21	0.10	0.19	0.17	0.14	31
3	2	4	4	4	4	3-5	0.10	0.10	0.10	0.10				31
3	2	4	4	4	4	10	0.10	0.10	0.10	0.10				31
3	2	4	4	4	4	15	0.10	0.14	0.14	0.10				31
3	2	4	4	4	4	20	0.11	0.18	0.19	0.10				31
3	2	4	4	4	4	25	0.14	0.23	0.23	0.10				31
3	2	4	4	4	4	30	0.17	0.27	0.27	0.10				31
3	2	4	4	4	4	35	0.20	0.31	0.31	0.10				31

3 ft by 3 ft by 4 in.														
Span ft	Rise ft	Top in.	Bottom in.	Side in.	Haunch in.	Design Earth Cover ft	Circumferential Reinforcement Areas, in. ² /ft							"M," in.
							A ₃₁	A ₃₂	A ₃₃	A ₃₄	A ₃₅	A ₃₇	A ₃₈	
3	3	7	6	4	4	0-2	0.17	0.40	0.23	0.10	0.20	0.17	0.14	31
3	3	4	4	4	4	2-3	0.10	0.25	0.25	0.10				31
3	3	4	4	4	4	3-5	0.10	0.10	0.11	0.10				31
3	3	4	4	4	4	10	0.10	0.11	0.11	0.10				31
3	3	4	4	4	4	15	0.10	0.15	0.16	0.10				31
3	3	4	4	4	4	20	0.10	0.20	0.20	0.10				31
3	3	4	4	4	4	25	0.10	0.24	0.25	0.10				31
3	3	4	4	4	4	30	0.12	0.29	0.29	0.10				31
3	3	4	4	4	4	35	0.14	0.33	0.34	0.10				31

4 ft by 2 ft by 5 in.														
Span ft	Rise ft	Top in.	Bottom in.	Side in.	Haunch in.	Design Earth Cover ft	Circumferential Reinforcement Areas, in. ² /ft							"M," in.
							A ₄₁	A ₄₂	A ₄₃	A ₄₄	A ₄₅	A ₄₇	A ₄₈	
4	2	7.5	6	5	5	0-2	0.18	0.40	0.20	0.12	0.20	0.18	0.14	38
4	2	5	5	5	5	2-3	0.21	0.23	0.20	0.12				38
4	2	5	5	5	5	3-5	0.12	0.12	0.12	0.12				38
4	2	5	5	5	5	10	0.12	0.12	0.13	0.12				38
4	2	5	5	5	5	15	0.14	0.17	0.18	0.12				38
4	2	5	5	5	5	20	0.19	0.23	0.23	0.12				38
4	2	5	5	5	5	25	0.23	0.28	0.28	0.12				38
4	2	5	5	5	5	30	0.28	0.33	0.33	0.12				38
4	2	5	5	5	5	35	0.33	0.38	0.39	0.12				38

4 ft by 3 ft by 5 in.														
Span ft	Rise ft	Top in.	Bottom in.	Side in.	Haunch in.	Design Earth Cover ft	Circumferential Reinforcement Areas, in. ² /ft							"M," in.
							A ₄₁	A ₄₂	A ₄₃	A ₄₄	A ₄₅	A ₄₇	A ₄₈	
4	3	7.5	6	5	5	0-2	0.18	0.45	0.23	0.12	0.22	0.18	0.14	38
4	3	5	5	5	5	2-3	0.16	0.28	0.25	0.12				38
4	3	5	5	5	5	3-5	0.12	0.12	0.13	0.12				38
4	3	5	5	5	5	10	0.12	0.14	0.15	0.12				38
4	3	5	5	5	5	15	0.12	0.20	0.20	0.12				38
4	3	5	5	5	5	20	0.14	0.26	0.26	0.12				38
4	3	5	5	5	5	25	0.17	0.32	0.32	0.12				38
4	3	5	5	5	5	30	0.21	0.38	0.38	0.12				38
4	3	5	5	5	5	35	0.25	0.44	0.44	0.12				38

4 ft by 4 ft by 5 in.														
Span ft	Rise ft	Top in.	Bottom in.	Side in.	Haunch in.	Design Earth Cover ft	Circumferential Reinforcement Areas, in. ² /ft							"M," in.
							A ₄₁	A ₄₂	A ₄₃	A ₄₄	A ₄₅	A ₄₇	A ₄₈	
4	4	7.5	6	5	5	0-2	0.18	0.47	0.25	0.12	0.23	0.18	0.14	38
4	4	5	5	5	5	2-3	0.13	0.31	0.28	0.12				38



Section 7, **Design**; ASTM C1433:

- 7.1: Design Tables:reinforcement details shall be as prescribed in Table 1 or Table 2 and Figs. 1-4 **subject to the provisions of Section 12** (Permissible Variations)
- Table 1: sections are designed for combined earth dead load and AASHTO **HS20** live load conditions
- Table 2: sections are designed for combined earth dead load and **interstate** live load conditions **WHEN** the interstate live loading **EXCEEDS** the HS20 live loading.
- Note 2- The tabular designs in this specification were prepared according to AASHTO LRFD Bridge Design Specifications for C1577 & AASHTO STandard Specs for Highway Bridges..... for C1433.
- 7.2: Modified and Special Designs for Monolithic Structures: The **MANUFACTURER** shall **request approval by the purchaser** of modified designs that differ from the designs in Section 7.1; or special designs for sizes and loads other than those shown in Tables 1 and 2. **More detail on Special Designs later today.**



Allowable Wire Bending Configurations

- The bending steel at 45° as you showed in the sketches creates a development length issue. This issue plus we must have plenty of “wiggle” variance for the production crew to fit the bend into the haunch, it is recommended the 2” nominal cover.
- This 2” cover provides a small incremental increase in the development length, but not nearly the L_{dh} distance.
- L_{dh} = the length in the tension of deformed bar or wire with a standard hook, measured from the critical section to the outside end of the hook. (The straight embedment length between the critical section and start of the hook [point of tangency] plus inside radius of bend and one bar diameter).



Allowable Wire Bending Configurations

- A minimum bend and maximum bend radius must be determined.
- Typically manufacturers will trim out the steel that would interfere in the region of the tongue forming pallet (joint would be in compression).
- An option would be to add a shaped bend section that will replace the cut section.
 - This might be a radius to match the joint minus cover.
 - This might be a 45° piece to follow the haunch including cover, or somewhere between 1" - 2".
- There is a relatively broad range of opinions on what haunch reinforcement is or should be.



- **NEW: Table A – Minimum Dimensions of Bends**

- **Table A—Minimum Dimensions of Bends**

Bar Size and Use	Minimum Radius	Minimum Diameter
Welded Wire Reinforcement—Less than W/D 6	2.0db	4.0db
Welded Wire Reinforcement—W/D 6 and Larger Wire	4.0db	8.0db
No. 3 Through No. 5—General	3.0db	6.0db
No. 3 Through No. 5—Stirrups and Ties	2.0db	4.0db
No. 6 Through No. 8—General	3.0db	6.0db

- **NEW ADDITION to Section 7.3:**

- If the longitudinal wires will be in a bend and if the welded wire reinforcement cannot be bent with the longitudinal wires to the outside of the bend, bends with inside diameters less than
- **8.0 db shall not be located less than 4.0 db** from the nearest welded intersection. When bending welded-wire reinforcement, longitudinal wires **do not need to follow the maximum spacing requirements of 7.4 within the bend radius.**
- A maximum space of 16 in. **is permitted at the bend location** to prevent localized fractures at weld intersections.



- Section 7, Note 3:
- Construction procedures, such as heavy equipment or stockpiling of material over or adjacent to a box structure, **can induce higher loads than those used for the structure's final design.** These construction and surcharge loads are approved as long as the final steel areas in the box are larger than those the box will experience in the final installation condition. The **DESIGN ENGINEER** should take into consideration the potential for higher loads induced by construction procedures in determining the final design of the box structure. *
- *It is my experience that this rarely gets asked of the **manufacturer** and regularly gets ignored and taken advantage of by the **contractor's** equipment and piling of soils on the job site.



- **NEW: Note 3.**
- NOTE 3—(Advisory)—The reinforcing areas shown in **Table 1** are based on the design earth covering and live load conditions described within this standard.
- **Depending on the means and methods used, handling and installation loads by either the manufacturer or contractor can induce stresses not considered within the development of the tables.**
- **These load could require additional steel reinforcement** beyond the minimums shown within the standard.
- **These handling and installation loads should be considered in the final design of the furnished precast concrete box section prior to fabrication.**



Section 7.3, Placement of Reinforcement:

- The cover of the concrete over the CIRCUMFERENTIAL REINFORCEMENT shall be 1”
- The INSIDE circumferential reinforcement shall extend into the tongue portion of the joint
- The OUTSIDE circumferential reinforcement shall extend into the groove portion of the joint (reinforcement in both joints!)
- The clear distance of the end circumferential wires shall not be less than ½” nor more than 2” from the ends of the box section.
- Reinforcement shall be assembled utilizing any combination of single or multiple layers of welded-wire reinforcement. **(Do not forget good concreting practices here!)**
- Multiple layers shall not be separated by more than the thickness of ONE longitudinal wire plus ¼”.
- Multiple layers shall be fastened together to form a single cage.



Section 7.3, Placement of Reinforcement:

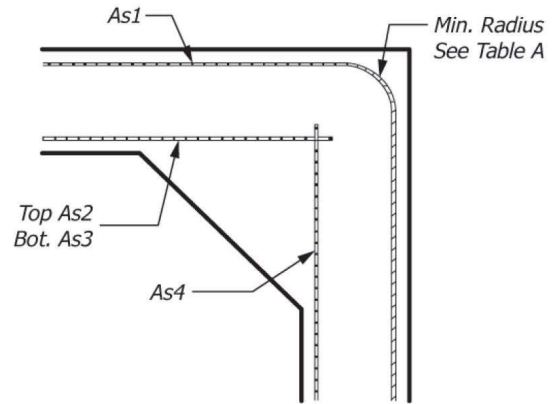

FIG. 3 Detail Inner Reinforcement

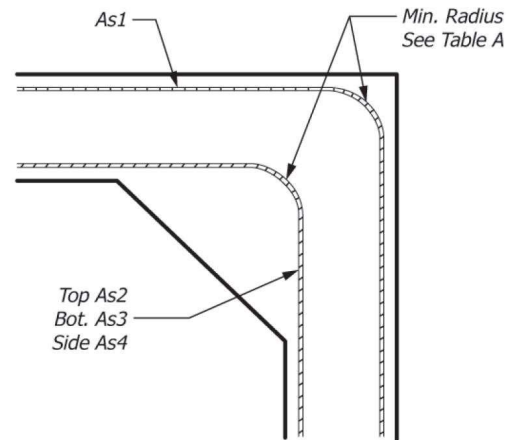

FIG. 4 Detail Option (see Fig. 3)



Section 7.3 Continued: Placement of Reinforcement:

- A common reinforcement unit (mat of WWR) may be utilized for **both As2 (or As3) and As4**,
- And also for **both As7 (or As8) and As1**
- With the **largest area** requirement governing, bending the reinforcement at the corners and waiving the extension requirements of Fig. 3 (see Fig. 4)
- When a single cage of multiple circumferential steel areas is used for As2 (or As3) and As4 reinforcement, the slab or wall requiring the larger steel area shall have this additional circumferential **steel extending for the full length of the slab or wall.**



Plant Practices; Placement of Reinforcement:

Typical Plant Reinforcing Detail:

1206-037

Reinforcing Detail

As1	0.610 in ² /ft
As2	0.610 in ² /ft
As3	0.494 in ² /ft
As4	0.240 in ² /ft
As7	0.240 in ² /ft
As8	0.240 in ² /ft

Distribution Steel (8"oc Max)

As5	0.240 in ² /ft
As6	0.240 in ² /ft

Mix Design
Aggregates
 Sand - 1495 lbs
 17A Stone - 1610 lbs
 Cement - 650 lbs
 Water - 240 lbs
Admixtures
 Water Reducer
 Air Entrainment

Strength: 6700 psi @ 28 days

Box Culvert Sections To Be Manufactured To MDOT 2012 Standard Specifications for Construction, Section 406.03, w/HL-93 Loading and Less Than 2.0' of Cover. The Design Will Meet All Other Applicable ASTM C-1577 Specifications.

Reinforcing Shown For Schematic Only. Actual Reinforcing Scheme To Be Determined At Time of Manufacture. Reinforcing Scheme Will Meet or Exceed All ASTM C-1577 Specifications. Reinforcing To Be 2" x 8" WWR Unless Otherwise Noted.

All Reinforcing Areas Shown Are Minimums.

Construction Traffic Over The Box Culvert Sections Shall Be Limited To A Maximum Single Axle Wheel Load of 16,000 lbs. or Two (Tandem) Wheel Loads of 13,000 lbs. Spaced 4 Feet Apart With A Minimum Cover of 3 Feet Shall Be In Place. This Minimum Cover Shall Be in Place Prior To Deployment of Heavy Earth Moving Equipment Larger Than a D-4 Dozer Weighing in Excess of 12 Tons and Having a Track Pressure of 80 psi or Greater Crossing The Structure.

At NO Time Shall Earth Moving Equipment Exceeding The Designated Box Culvert Design Loading Operate Over The Box Culvert Structure.

MDOT
STUL 70414 / 113317 A

NORTHERN CONCRETE PIPE

401 Kelton Street
Bay City, MI 48706
1 800 222 9918

5281 Lansing Road
Charlotte, MI 48813
1 800 874 9701

Proposed - 16' x 6' Precast Concrete Box Culvert

Milbocker & Sons
Allegan, MI

Lincoln Avenue At
Maplewood Drain

Date	Revised	Rev. No.	Drawn By	Scale
07 Jun 12	27 Jun 12	1	BmG	NTS



Plant Practices; Reinforcement



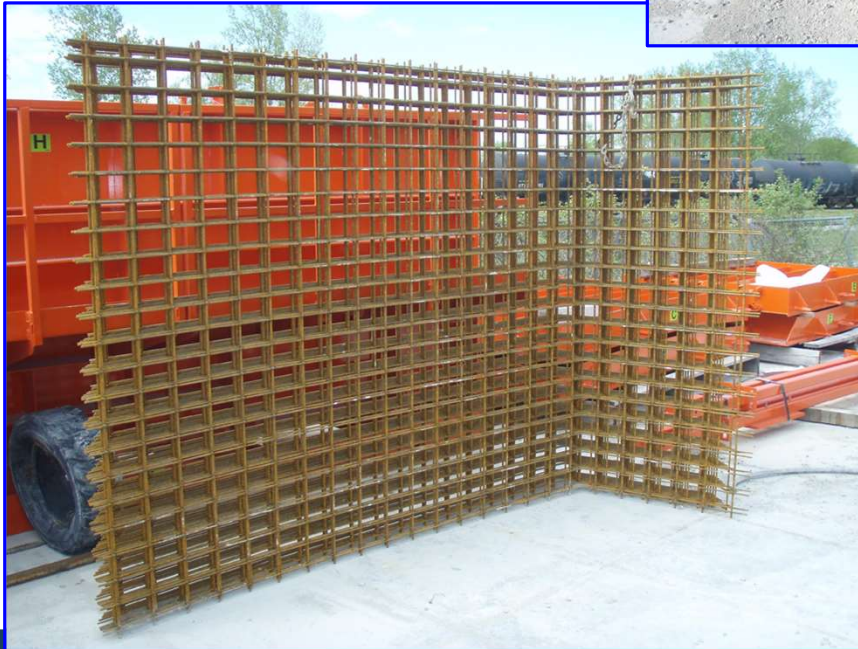



Section 7.3 Continued; Placement of Reinforcement:

- The welded-wire reinforcement shall be composed of circumferential and longitudinal wires meeting the requirements of 7.4 (Laps, Welds, and Spacing).....
- Longitudinal **distribution** reinforcement may be **welded-wire reinforcement or deformed billet-steel bars** and shall meet the requirements of 7.4.
- The ends of the longitudinal **distribution** reinforcement shall **not be more than 2"** from the ends of the box section.



Section 7.3 Continued: Longitudinal Reinforcement:

- Commonly called: LONGITUDINAL WIRES or TRANSVERSE WIRES
-shall contain sufficient longitudinal wires extending through the box section to maintain the shape and position of reinforcement.
- The exposure of the ends of the longitudinals, stirrups, or spacers that have been used to position the cages during the placement of the concrete shall NOT BE CAUSE FOR REJECTION. We have to point this out in EVERY PLANT TOUR we give.



Most, if not all of our ACPA Associate WWR manufacturing members have the ability to make mesh with varying wire size, wire spacing and location on a common mat to save you time and money on your manufacturing practices.

Please take the time to meet them at this Pipe School. Many are here in attendance today. They are anxious to help you improve your Plant wire efficiencies with their products.



WWR Advantages

- Variable wire size and spacing are possible on a common mat, configured to minimize excessive reinforcement steel areas and accommodate unique lap splice or development requirements where applicable

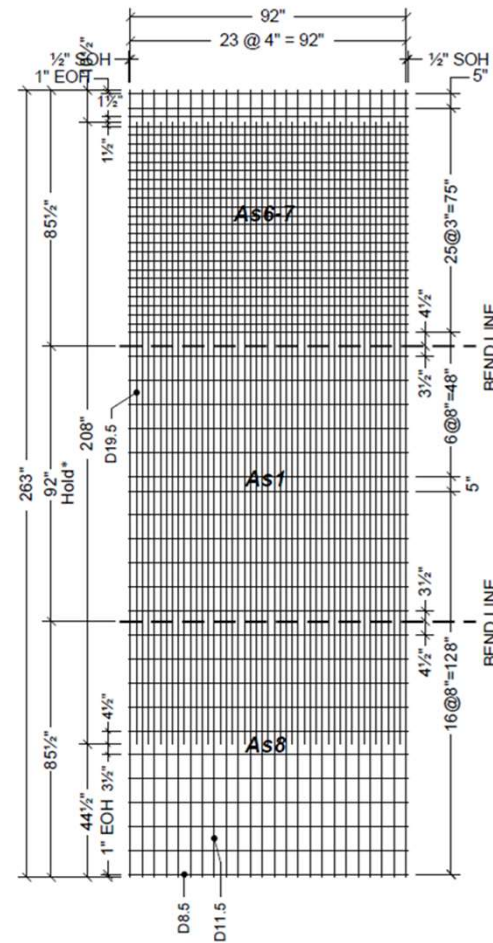



Plant Practices; Longitudinal DISTRIBUTION Mats:

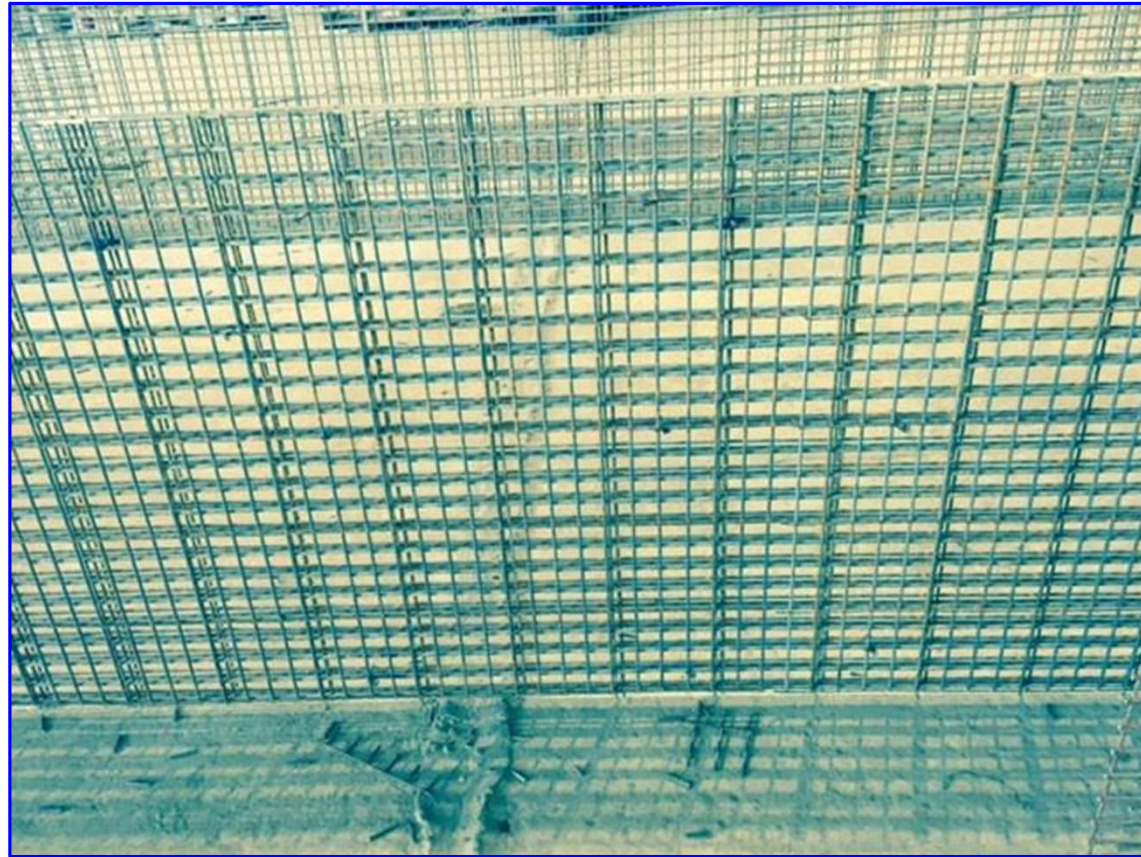



Section 7.4, ASTM C1433; Laps, Welds, and Spacing:

Note: This Sections has some differences between C1433 & C1577.

- Splices in the circumferential reinforcement shall be made by lapping. (NOT allowed to have shorter laps like pipe laps.)
- The overlap measured between the outermost longitudinal wires of each reinforcement sheet shall not be less than the spacing of the longitudinal wires plus 2" but NOT LESS THAN 10".
- If As1 is extended to the middle of either slab and connected, welded splices are not prohibited in the connection.
- When used, As7 and As8 shall be lapped with As1 as shown in Fig. 5 or Fig 6 (see also Fig. 7 and Fig 8.)



- **NEW: Section 7.4; Laps, Welds, and Spacing**
- If As2 or As3 are provided as separate sheets and cross As4
- in the region of the haunch, **to facilitate cage construction** the
- circumferential wires of each cage must be in contact as shown
- in **Fig. 3, Fig. 5, Fig. 9, Fig. 10, Fig. 11, and Fig. 12**

ASTM C1433: Fig 5 And Fig 6

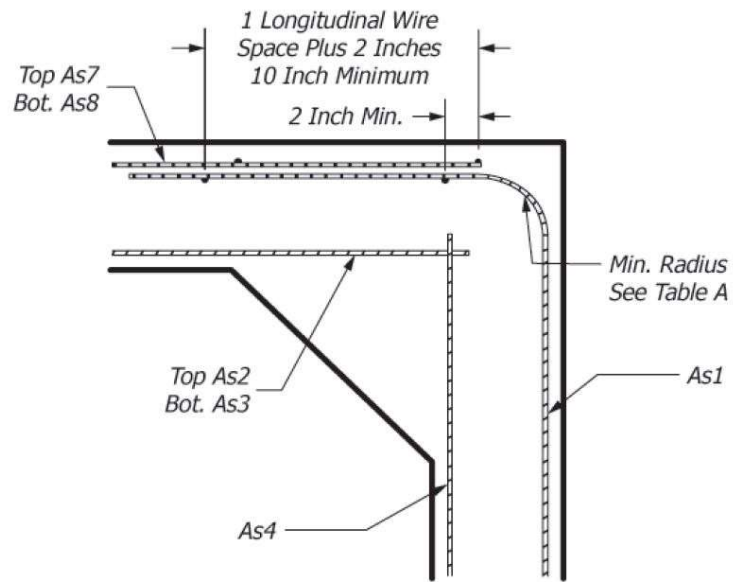

FIG. 5 Detailed Reinforcement Arrangement

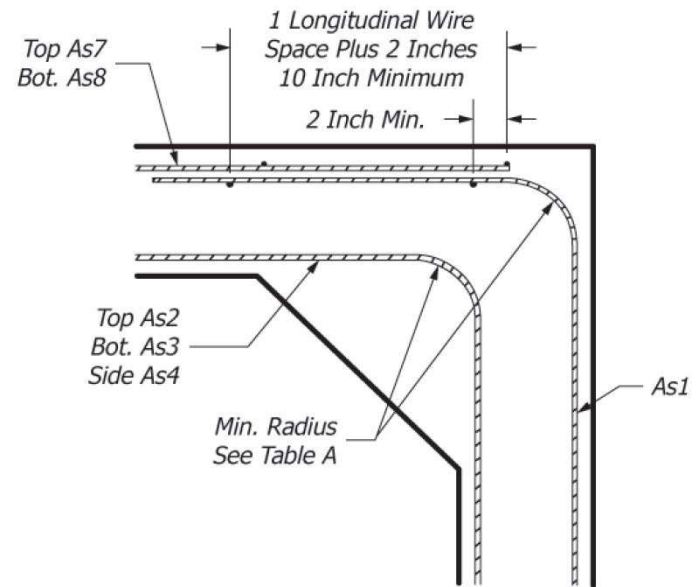

FIG. 6 Detail Option



ASTM C1433: Fig 7 And Fig 8

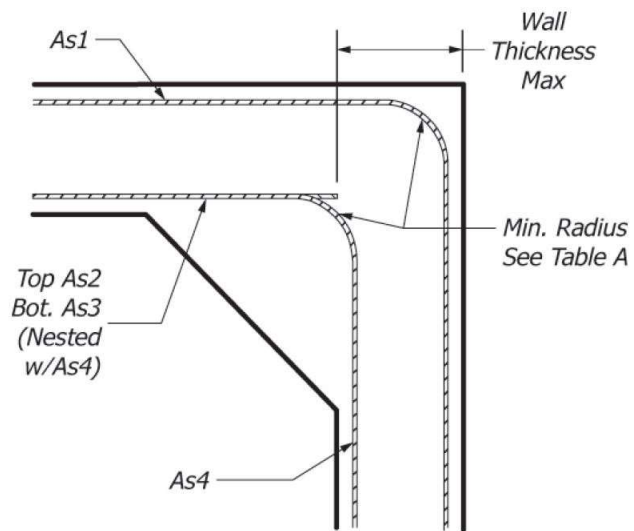

FIG. 7 Alternate Detail

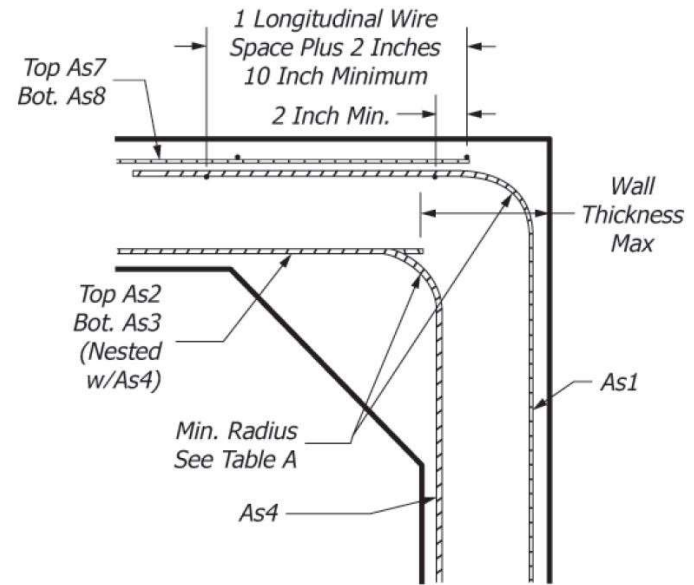

FIG. 8 Alternate Detail (see Fig. 5)

7.4 Laps, Welds, and Spacing—Splices in the circumferential reinforcement shall be made by lapping. The overlap measured between the outermost longitudinal wires of each reinforcement sheet shall not be less than the spacing of the longitudinal wires plus 2 in. but not less than 10 in. If As1 is extended to the middle of either slab and connected, welded splices are not prohibited in the connection. When used, As7 and As8 shall be lapped with As1 as shown in Fig. 5 or Fig. 6 (see also Fig. 7 and Fig. 8). If welds are made to circumferential reinforcement, they shall be made only to selected circumferential wires that are not less than 18 in. apart along the longitudinal axis of the box section. Also, when spacers are welded to circumferential wires, they shall be welded only to these selected circumferential wires. There shall be no welding to other circumferential wires, except it is not prohibited for As4 to be lapped and welded at any location or connected by welding at the corners to As2 and As3. No welds shall be made to As2 or As3 circumferential wires in the middle third of the span. (See Fig. 9 for welding restrictions.) When distribution reinforcement is to be fastened to a cage by welding, it shall be welded only to longitudinal wires and only near the ends of the box section. The spacing center to center of the circumferential wires shall not be less than 2 in. nor more than 4 in. The spacing center to center of the longitudinal wires shall not be more than 8 in.

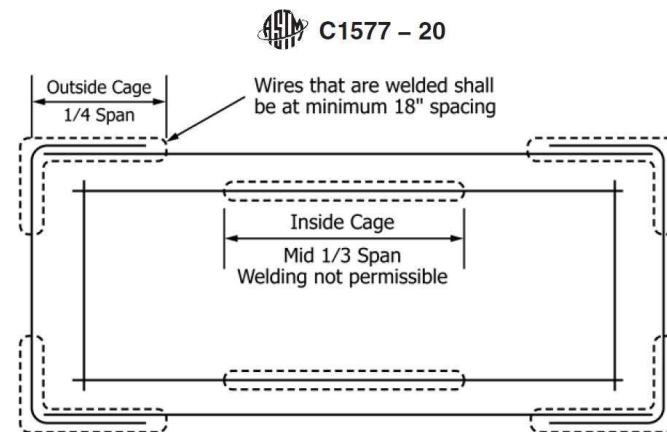

FIG. 15 Critical Zones of High Stress Where Welding is Restricted

Reference ASTM C-1433



Section 7.4 Continued; Laps, Welds, Spacing:

- If welds are made to circumferential reinforcement, they shall be made only to selected circumferential wire that are not less than 18" apart along the longitudinal axis of the box section.
- Also, when spacers are welded to circumferential wires, they shall be welded only to these selected circumferential wires.
- There shall be no welding to other circumferential wires, except it is not prohibited for As4 to be lapped and welded at any location or connected by welding at the corners to As2 and As3.
- No welds shall be made to As2 or As3 circumferential wires in the middle third of the SPAN.
- See Fig. 9 for welding restrictions (see next slide)



Figure 9; Critical Zones of High Stress Where Welding is Restricted

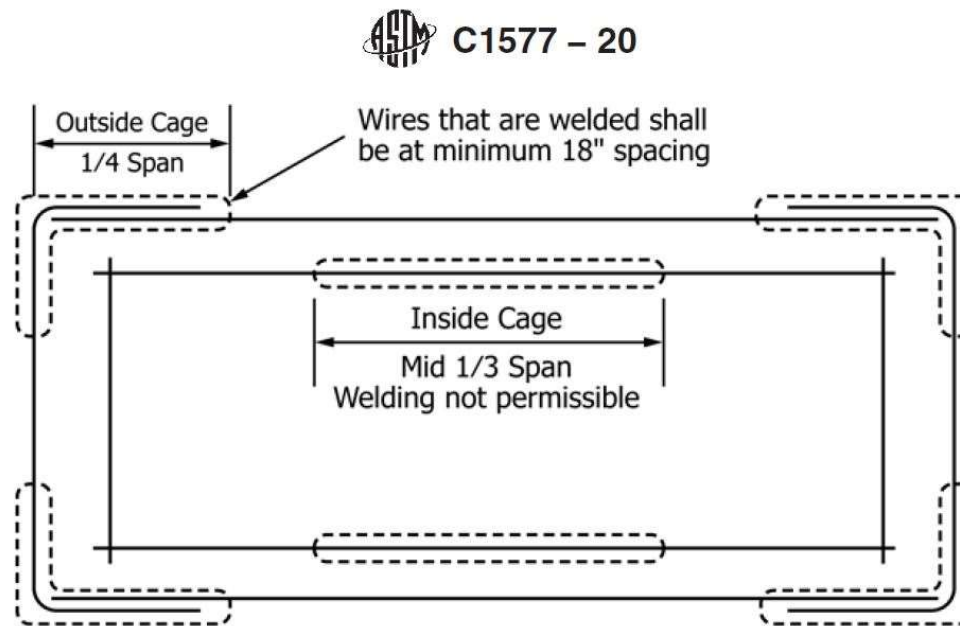

FIG. 15 Critical Zones of High Stress Where Welding is Restricted



Section 7.4 Continued; Laps, Welds, Spacing:

- When distribution reinforcement is to be fastened to a cage by welding, it shall be welded ONLY to longitudinal wires and ONLY near the ends of the box section.
- The spacing center to center of the circumferential wires shall not be less than 2" nor more than 4".
- The spacing center to center of the longitudinal wires shall not be more than 8".



CAGE SHAPE: Part #2; BENDING Reinforcement Mats

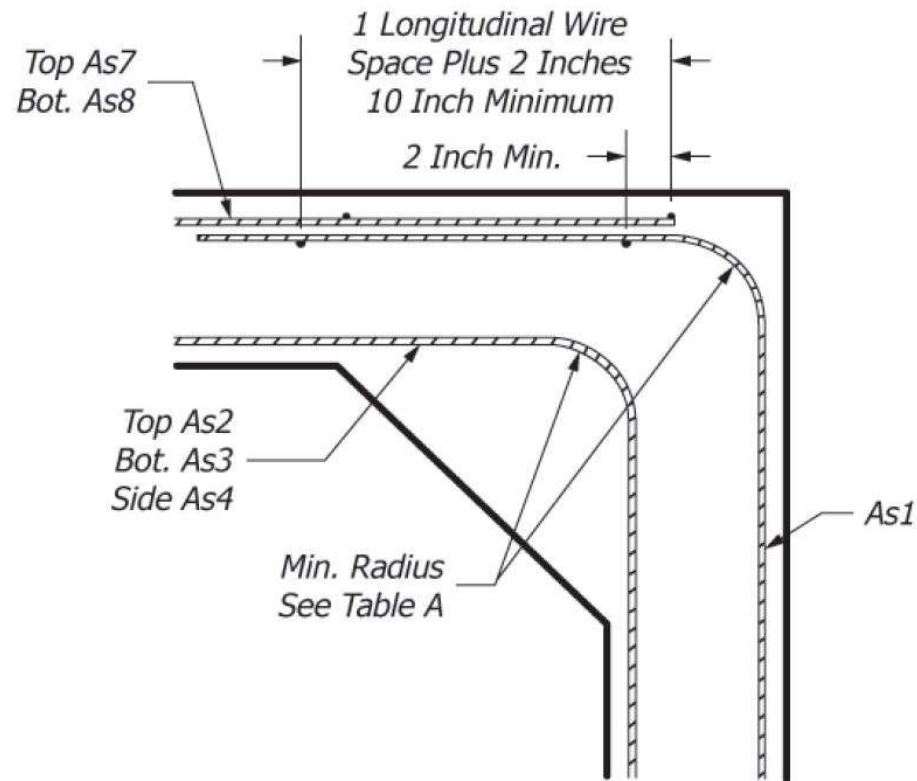

FIG. 6 Detail Option



CAGE SHAPE: BENDING Reinforcement Mats

- This is critical and not all Vendors either know or care about this.
- I have seen it done WRONG in TOO many Plants!

Minimum "W" Wire Bending Radius and Diameter

W#	Nominal Diameter (In)	4 x Dia = Min Radius (In)	= 2x radius = Min. Mandrel Dia (In)
W3	.195"	0.78"	1.56"
W4	.225"	0.9"	1.8"
W5	.252"	1.01"	2.02"
W6	.276"	1.10"	2.21"
W7	.298"	1.19"	2.38"
W8	.319"	1.28"	2.55"
W9	.338"	1.35"	2.70"
W10	.356"	1.42"	2.85"
W11	.374"	1.50"	3.0"
W12	.390	1.56"	3.12"



CAGE SHAPE: BENDING Reinforcement Mats

- This is critical and not all Vendors either know or care about this.
- I have seen it done WRONG in TOO many Plants!

- “Make sure when bending that you use the proper diameter bending bar that is specified so you don’t snap the bars on the wire.”

- “The closer to the transverse bar you are, the more likely you are to break a bar.”when bending the mat.



Cage Location in the Product Wall

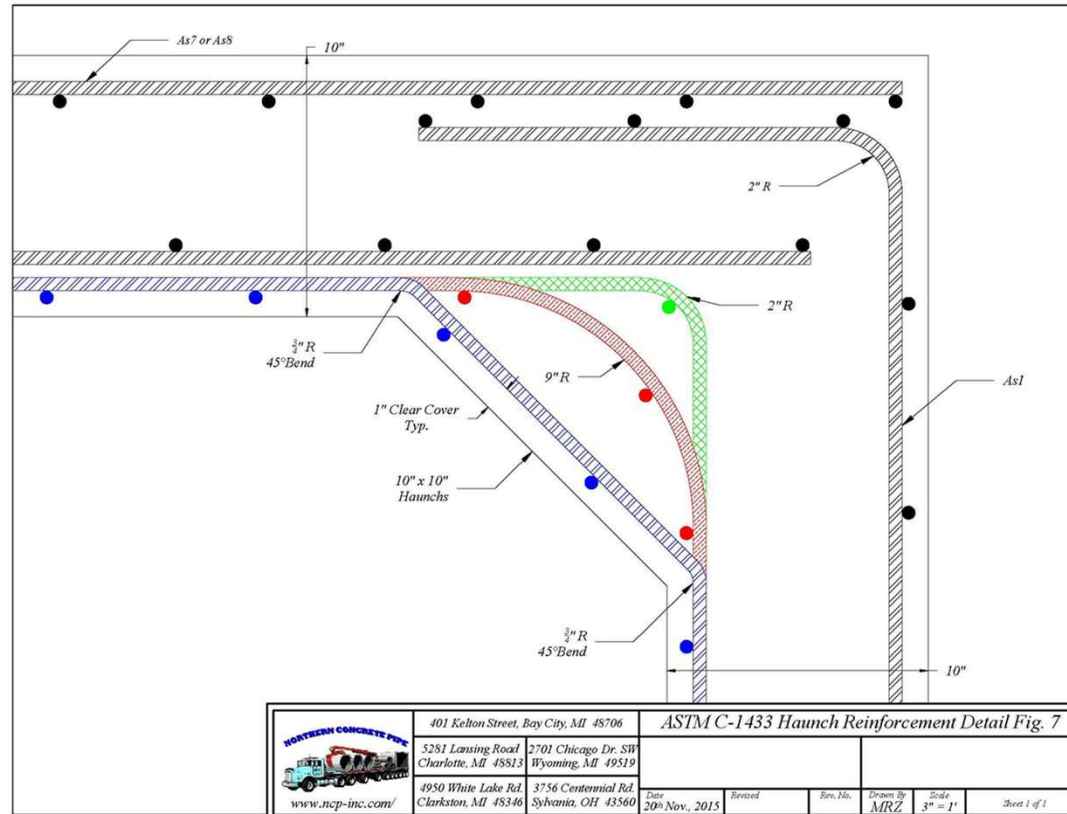



Cage Location in the Product Wall

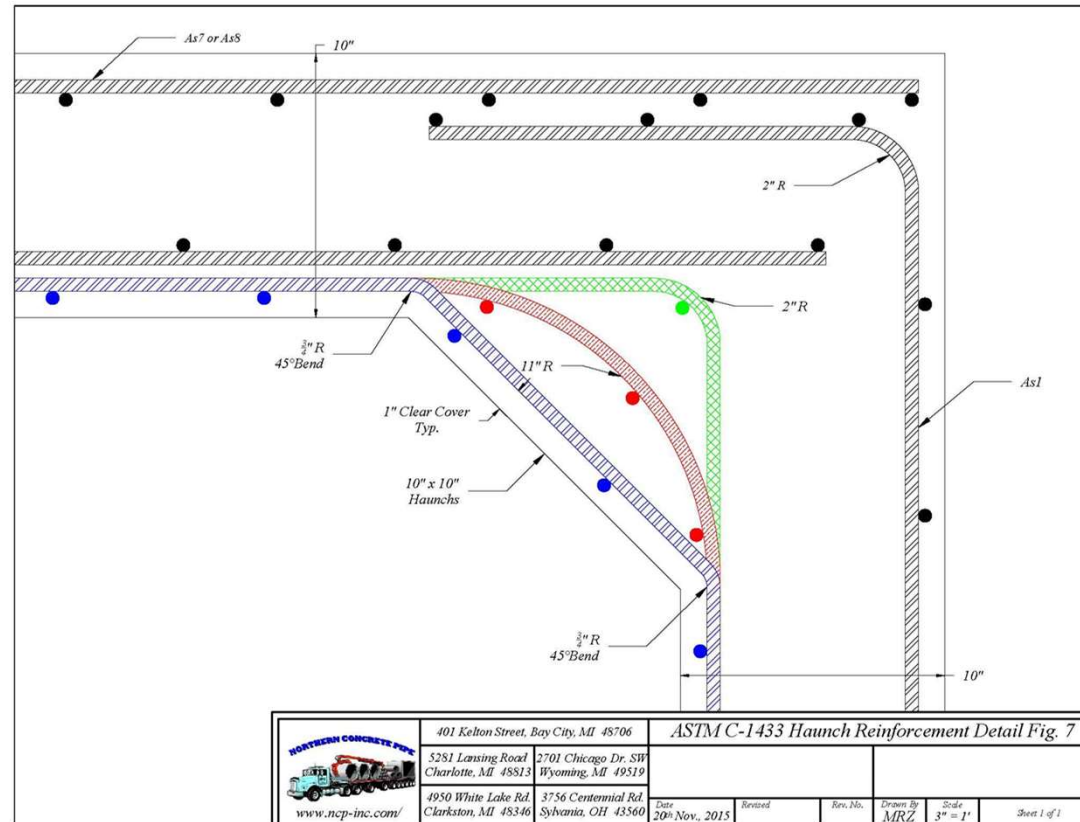

Allowable Wire Bending Configurations

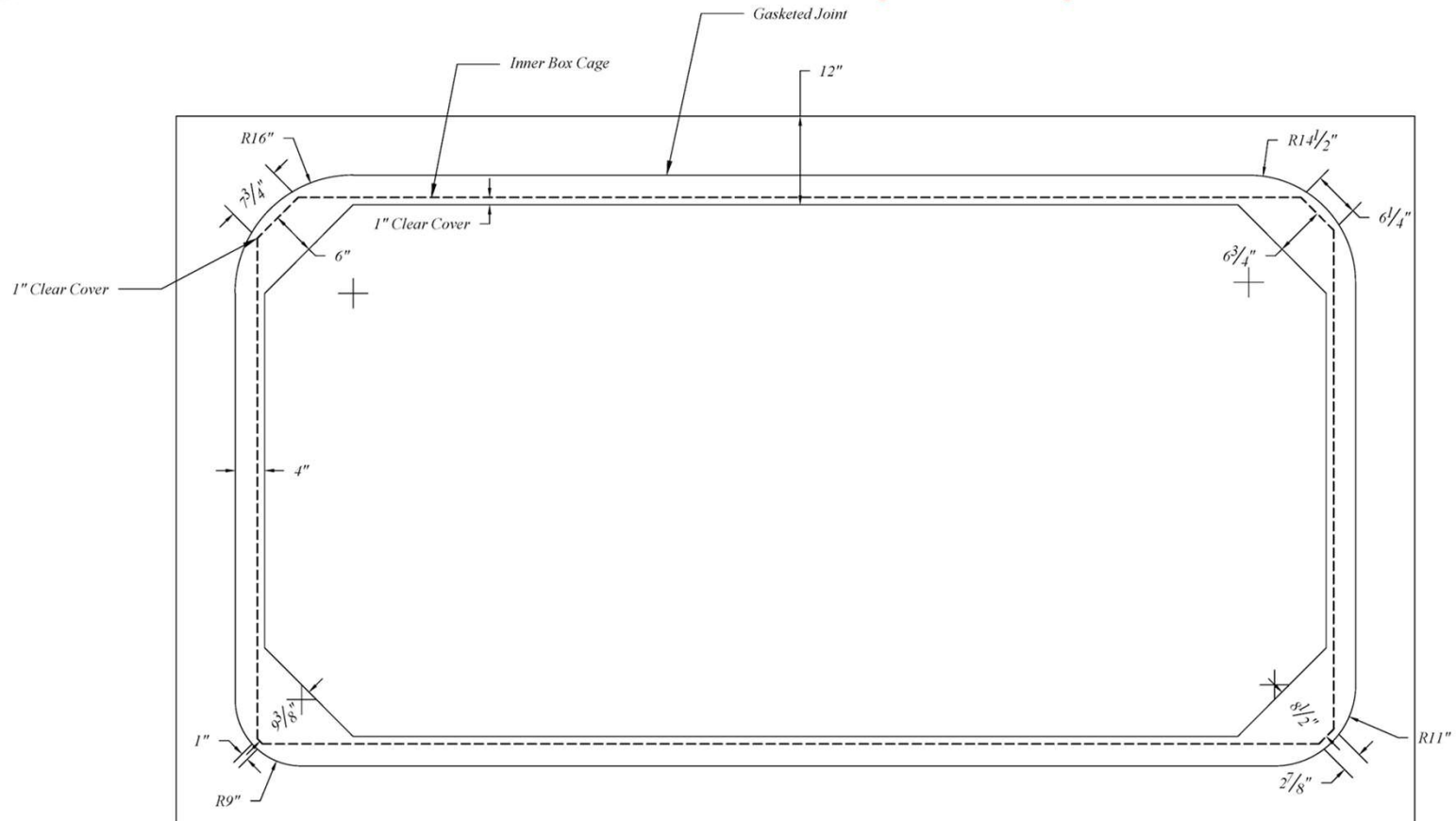

- (4) Different radii with bends in welded wire reinforcement while leaving 1" cover to the joint former.

Allowable Wire Bending Configurations

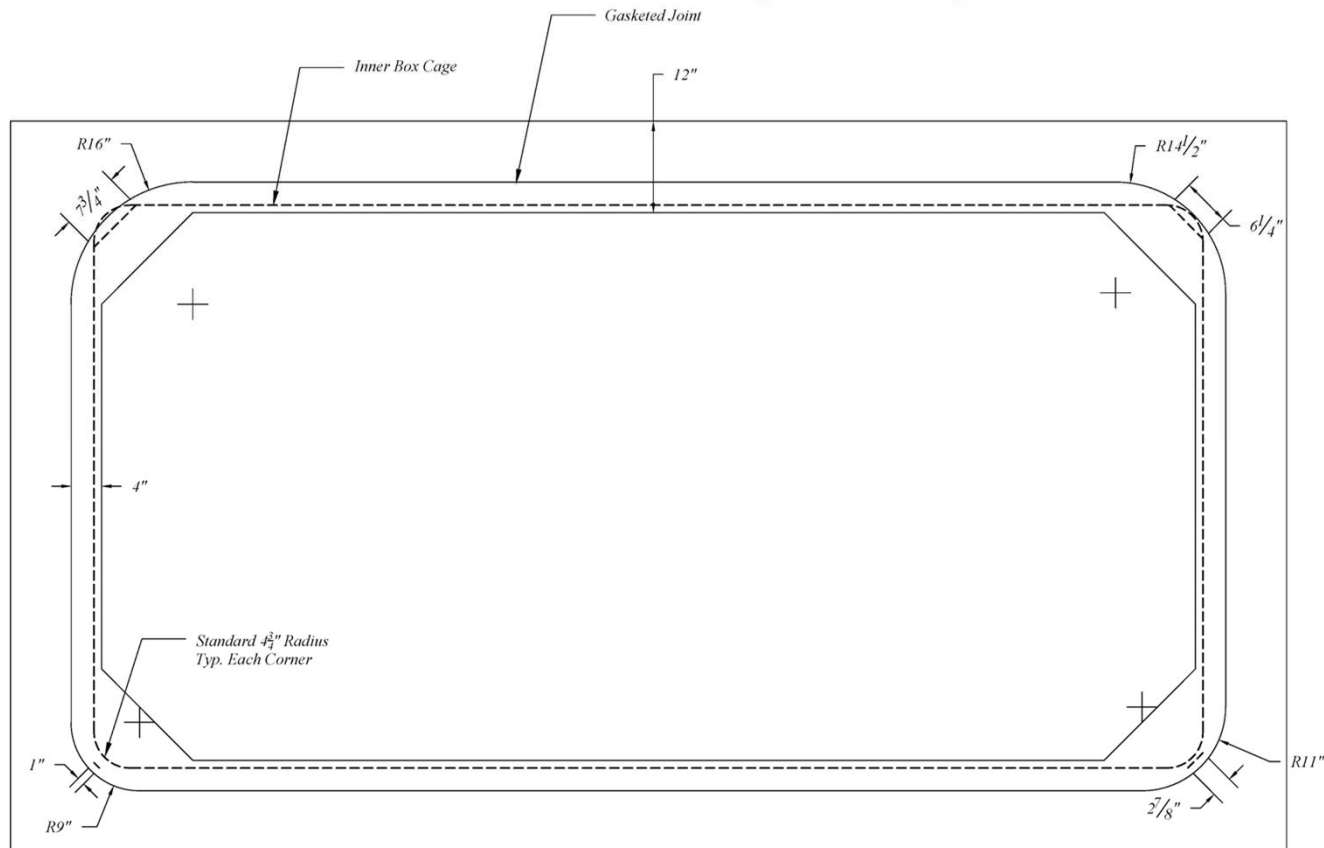

- (4) Different radii with bends in welded wire reinforcement using our standard curved cage with the radius of the bending roller used in our plant, while keeping 1" cover to the joint former.

Allowable Wire Bending Configurations

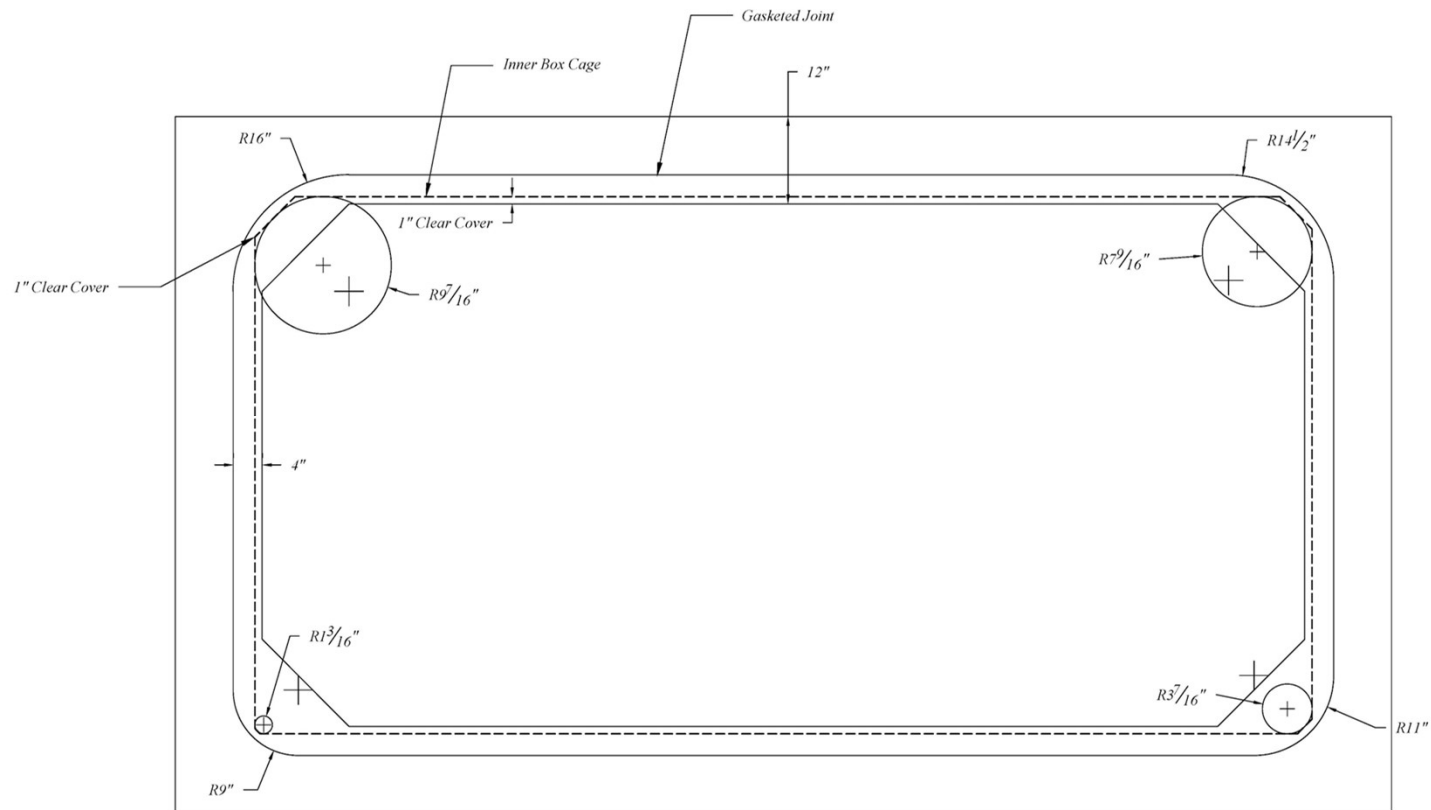

- (4) Different radii with bends in welded wire reinforcement using our standard curved cage with a custom cage roller, while keeping 1" cover to the joint former.



Allowable Wire Bending Configurations

- Each manufacturer can choose their different box culvert joint former to meet their needs. Should this radius be left up to the operators in the plant?NO!
- Whatever the decision is must be decided by the management of the company, not by a single individual **because you took this class.**



STANDARD HOOK DETAILS in accordance with ACI 318 Building Code

All grades of steel (minimum yield strengths)

D = Finished inside bend diameter
(includes springback)

d = Bar diameter

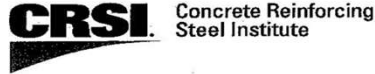
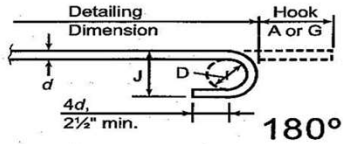

ACI 318 min. bend diameter:
6d for #3 through #8
8d for #9, #10 and #11
10d for #14 and #18

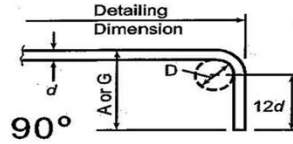

RECOMMENDED END HOOK DIMENSIONS

BAR SIZE	D	180° HOOKS		90° HOOKS
		A or G	J	A or G
#3	2 1/4"	0' - 5"	0' - 3"	0' - 6"
#4	3"	0' - 6"	0' - 4"	0' - 8"
#5	3 3/4"	0' - 7"	0' - 5"	0' - 10"
#6	4 1/2"	0' - 8"	0' - 6"	1' - 0"
#7	5 1/4"	0' - 10"	0' - 7"	1' - 2"
#8	6"	0' - 11"	0' - 8"	1' - 4"
#9	9 1/2"	1' - 3"	0' - 11 3/4"	1' - 7"
#10	10 3/4"	1' - 5"	1' - 1 1/4"	1' - 10"
#11	12"	1' - 7"	1' - 2 3/4"	2' - 0"
#14	18 1/4"	2' - 3"	1' - 9 3/4"	2' - 7"
#18	24"	3' - 0"	2' - 4 1/2"	3' - 5"

STEEL TYPE	BAR SIZE RANGE	GRADE	MINIMUM YIELD (ksi)	MINIMUM TENSILE (ksi)
Carbon A615	#3 - #6	40	40	60
	#3 - #20	60	60	90
	#3 - #20	75	75	100
	#3 - #20	80	80	105
	#3 - #20	100	100	115
Low-Alloy A706	#3 - #18	60	60	80
	#3 - #18	80	80	100
Stainless	#3 - #18	60	60	90
	#3 - #18	75	75	100
	#3 - #18	80	80	100
Rail & Axle A996	#3 - #8	40	40	70
	#3 - #8	50	50	80
	#3 - #11	60	60	90
Low-Carbon	#3 - #18	100	100	150
	#3 - #11	120	120	150

Allowable Wire Bending Configurations

- CRSI recommended minimal bend radii



ASTM STANDARD REINFORCING BARS

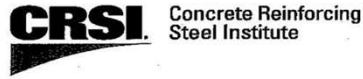

Allowable Wire Bending Configurations

BAR SIZE DESIGNATION	NOMINAL DIMENSIONS		
	AREA (in. ²)	WEIGHT (lb/ft)	DIAMETER (in.)
#3	0.11	0.376	0.375
#4	0.20	0.668	0.500
#5	0.31	1.043	0.625
#6	0.44	1.502	0.750
#7	0.60	2.044	0.875
#8	0.79	2.670	1.000
#9	1.00	3.400	1.128
#10	1.27	4.303	1.270
#11	1.56	5.313	1.410
#14	2.25	7.65	1.693
#18	4.00	13.60	2.257
#20	4.91	16.69	2.50

D = Finished inside bend diameter (includes springback)
 d = Bar diameter

ACI 318 min. bend diameter:
 6d for #3 through #8
 8d for #9, #10 and #11
 10d for #14 and #18

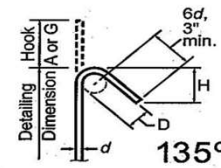
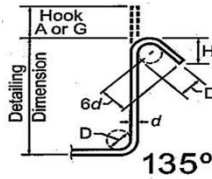
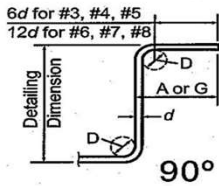

RECOMMENDED STIRRUP/TIE HOOK DIMENSIONS					RECOMMENDED SEISMIC STIRRUP/TIE HOOK DIMENSIONS				
BAR SIZE	D	90°		135°		BAR SIZE	135° SEISMIC HOOK		
		A or G	A or G	H*	D		A or G	H*	
#3	1 1/2"	0'-4"	4"	2 1/2"	#3	1 1/2"	4 1/4"	3"	
#4	2"	0'-4 1/2"	4 1/2"	3"	#4	2"	4 1/2"	3"	
#5	2 1/2"	0'-6"	5 1/2"	3 3/4"	#5	2 1/2"	5 1/2"	3 3/4"	
#6	4 1/2"	1'-0"	8"	4 1/2"	#6	4 1/2"	8"	4 1/2"	
#7	5 1/4"	1'-2"	9"	5 1/4"	#7	5 1/4"	9"	5 1/4"	
#8	6"	1'-4"	10 1/2"	6"	#8	6"	10 1/2"	6"	

* H dimension is approximate



Allowable Wire Bending Configurations

- “We should follow the requirement of the AASHTO LRFD Bridge Design Specification since that is what ASTM C 1577 is supposed to be based upon”. / one Task Group member.

5-114

AASHTO LRFD BRIDGE DES

5.10.2.3—Minimum Bend Diameters

The diameter of a bar bend, measured on the inside of the bar, shall not be less than that specified in Table 5.10.2.3-1.

Table 5.10.2.3-1—Minimum Diameters of Bend

Bar Size and Use	Minimum Diameter
No. 3 through No. 5—General	$6.0d_b$
No. 3 through No. 5—Stirrups and Ties	$4.0d_b$
No. 6 through No. 8—General	$6.0d_b$
No. 9, No. 10, and No. 11	$8.0d_b$
No. 14 and No. 18	$10.0d_b$

The inside diameter of bend for stirrups and ties in plain or deformed welded wire fabric shall not be less than $4.0d_b$ for deformed wire larger than D6 and $2.0d_b$ for all other wire sizes. Bends with inside diameters of less than $8.0d_b$ shall not be located less than $4.0d_b$ from the nearest welded intersection.



- **NEW: Section 7.5; addressing the ASTM TG concerns of the previous slides in this Specification Development.**
- *7.5 Extension of As2/3 Reinforcing at the Haunch—As2 and As3 reinforcing shall meet the following requirements in the region of the haunch:*
- *(1) Starting point for extension length for As2 / As3 to be defined as the tip of the haunch.*
- *(2) The distance from the starting point to the last crosswire of a mesh sheet excluding ends of wires beyond the last crosswire, shall be a minimum of one crosswire space plus 2 in.*
- *(3) Wire length beyond the last crosswire must be sufficient for the As2 and As3 layer to at a minimum cross the As4 layer if provided as separate sheets.*
- *(4) When As2 or As3 sheets are provided in combination with As4 as a nested sheet, the sheet may be bent in one of the following configurations or as approved by the owner:*
- *(a) Single 90 degree bend meeting the minimum bend diameter requirements of Table A with appropriate overlap provided with As4 sheets in the wall.*
- *(*



- **NEW; Section 7.5 Continued:**
 - *b)* Double 45 degree bend meeting minimum bend diameter requirements of Table A to allow the reinforcement to follow the angle haunch with appropriate clear cover. For this option, nested wires providing A_s2 steel area shall extend beyond the midpoint of the haunch.
 - *(c)* Single or multiple radius bend meeting minimum bend diameter requirements of Table A and bent to follow joint and or haunch dimensions with appropriate clear cover.
 - *(d)* It is not prohibited to trim mesh cages within the limits of a joint when the cage does not follow the joint. Adequate replacement steel must be provided within the trimmed area to maintain appropriate reinforcing area and appropriate clear cover.



CAGE SHAPE: BENDING Reinforcement Mats

What Is WRONG with this home-made wire bender?





Plant Practices

- The pipe mandrel was cut off the hydraulic vertical anvil!





CAGE SHAPE: BENDING Reinforcement Mats



- Bend a piece of large wire and show that TORN wire Outside Edge.



Plant Practices:

Cage Shape; Bending Reinforcing Mats:





Plant Practices; **Bending Wire Mesh**

“When using wire mesh sheets that have to be bent, **Northern always adds an additional space** so when bending the mat, you are able to stay away from the transverse wires and at the same time, keep your minimum bend leg length on your wire.”

Example: 2 transverse bars plus 2” per ASTM is a minimum of 10” as required with 8” transverse bars. Northern adds another 8” space so we will have our 10” on one leg and more than 10” on the other leg. You may sometimes have more than the required 10” on BOTH legs.

We have many that end up with an 18” leg on one side so we are sure we have OUR Company required minimums.

Make sense?.....Questions on this?



Plant Practices;

Cage Shape: Bending Reinforcing Mats:





Plant Practices





Plant Practices





Plant Practices

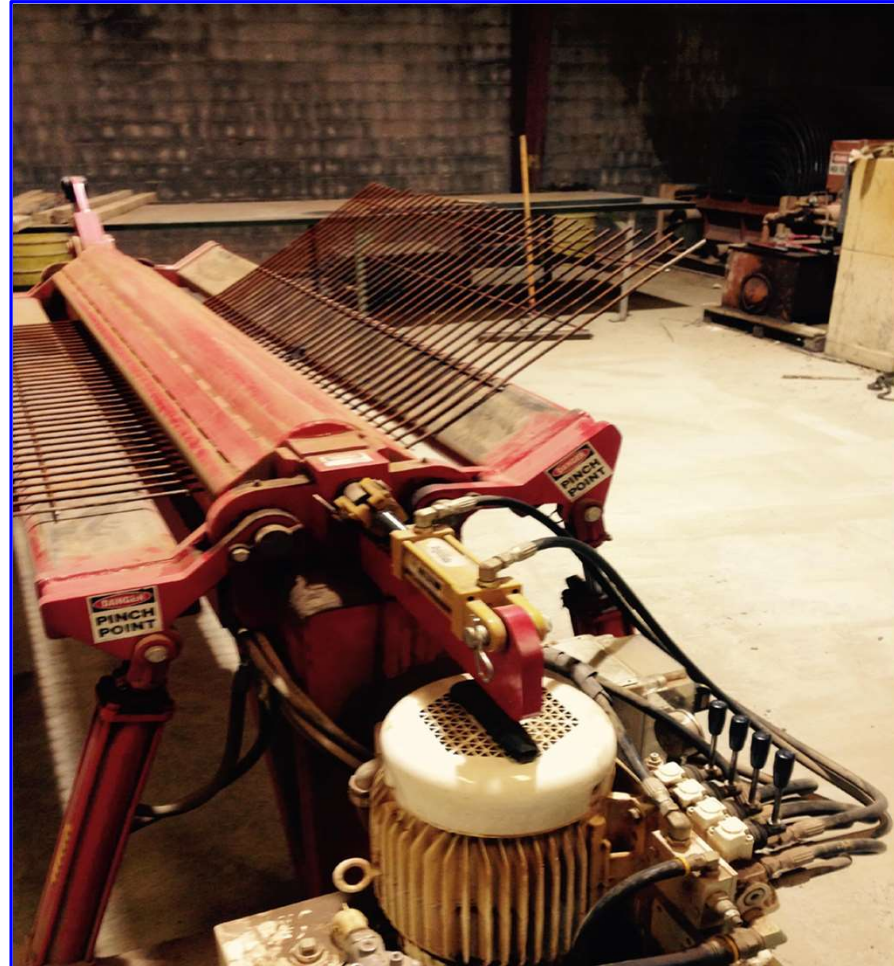



Plant Practices

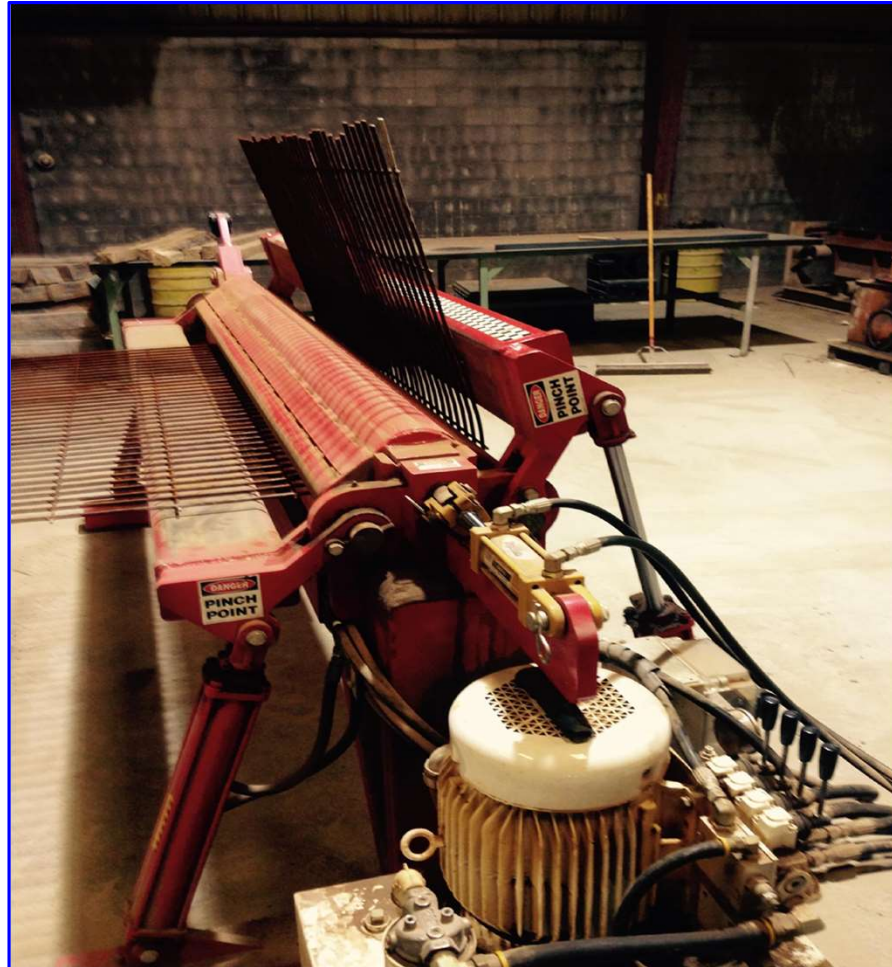



Plant Practices

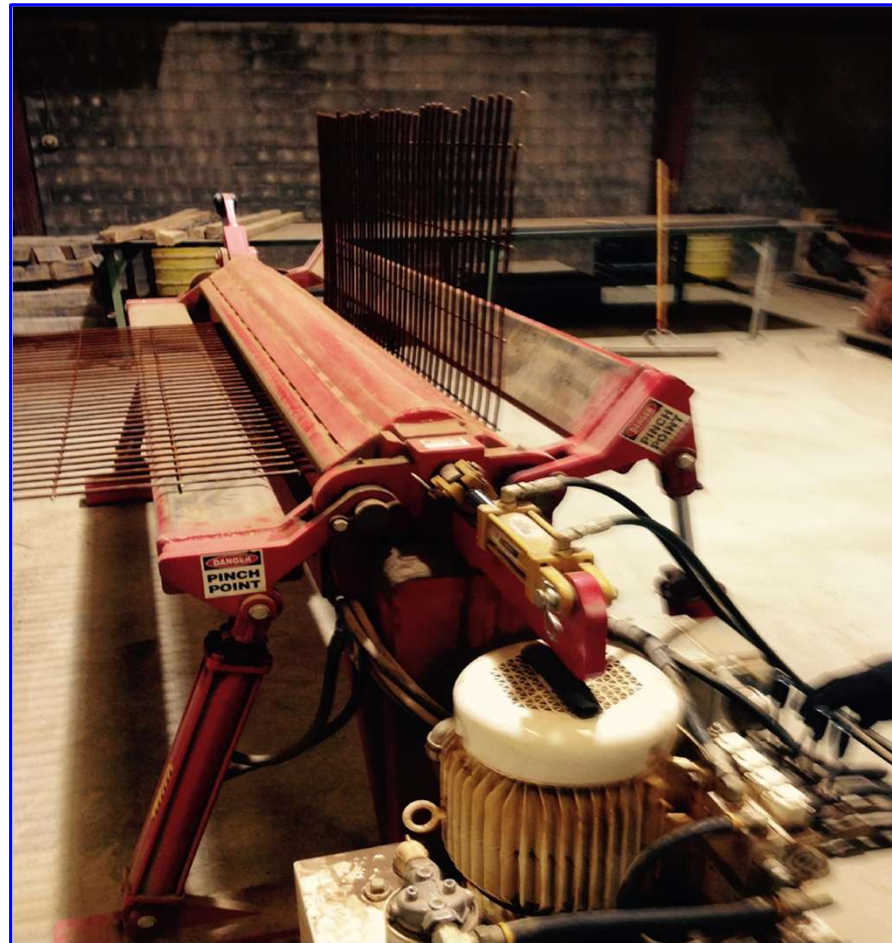



Plant Practices; Bending Mats

“If you are not sure that your wire is at a 90 degree angle after bending, when bending your wire mat, use a three foot square to see if the wire is bent at the proper angle and to verify that it is true along the bend and the same at the top and bottom.”

“ If we **(Northen) are more than 1/4” off** of our measurements, we will flatten the wire if possible and use it again. You quickly learn to do it rightONCE!”



Cage Shape – Handling Holes & Handling Devices (Lift Eyes)

- Section 10; Manufacture:
- Section 10.4 states: Handling devices or holes shall be permitted in each box section for the purpose of handling and laying.



- Plant Practices
- **Cautions:**
- 2” circumferential wire spacing in an **8’ lay length** box culvert: if you **cut** TWO wires for a handling hole and you have cut 2 of 48 which is a 4.2% **reduction.**
- Welding handling devices is restricted in certain box culvert locations and has further consideration required when using shear reinforcing.



Cage Length

As previously shown on slides about **CAGE SHAPE**: Section 7.3 States:

- The clear distance of the end **circumferential** wires shall not be less than $\frac{1}{2}$ " nor more than 2" from the ends of the box section.



7.4 Laps, Welds, and Spacing—Splices in the circumferential reinforcement shall be made by lapping. The overlap measured between the outermost longitudinal wires of each reinforcement sheet shall not be less than the spacing of the longitudinal wires plus 2 in. but not less than 10 in. If As1 is extended to the middle of either slab and connected, welded splices are not prohibited in the connection. When used, As7 and As8 shall be lapped with As1 as shown in Fig. 5 or Fig. 6 (see also Fig. 7 and Fig. 8). If welds are made to circumferential reinforcement, they shall be made only to selected circumferential wires that are not less than 18 in. apart along the longitudinal axis of the box section. Also, when spacers are welded to circumferential wires, they shall be welded only to these selected circumferential wires. There shall be no welding to other circumferential wires, except it is not prohibited for As4 to be lapped and welded at any location or connected by welding at the corners to As2 and As3. No welds shall be made to As2 or As3 circumferential wires in the middle third of the span. (See Fig. 9 for welding restrictions.) When distribution reinforcement is to be fastened to a cage by welding, it shall be welded only to longitudinal wires and only near the ends of the box section. The spacing center to center of the circumferential wires shall not be less than 2 in. nor more than 4 in. The spacing center to center of the longitudinal wires shall not be more than 8 in.

ASTM C1577 - 20

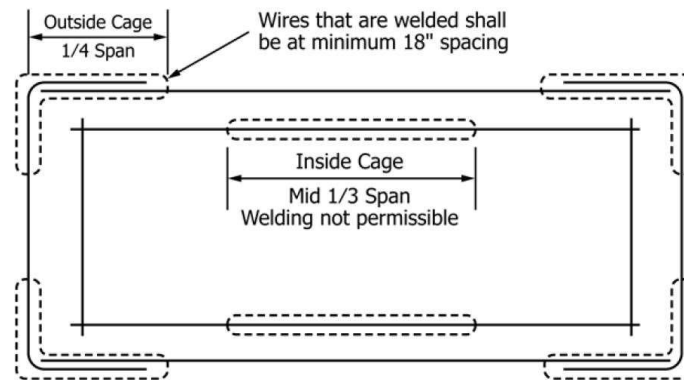

FIG. 15 Critical Zones of High Stress Where Welding is Restricted

Reference ASTM C-1433



Plant Practices; Handling Holes:

After pinning the inner and outer cages into one structure, the next step we do is to cut the lift holes and bend the wire out of the way and bag tie it. Then we reinforce around the plug hole with the vertical #4 rebar Vertically on both sides of the opening.

For the **Dry Cast producers** in the room; HOW do you secure your lift hole formers or anchors into the cage for pouring concrete and not moving the former or insert?



Plant Practices; Handling Holes:





Plant Practices; Handling Holes

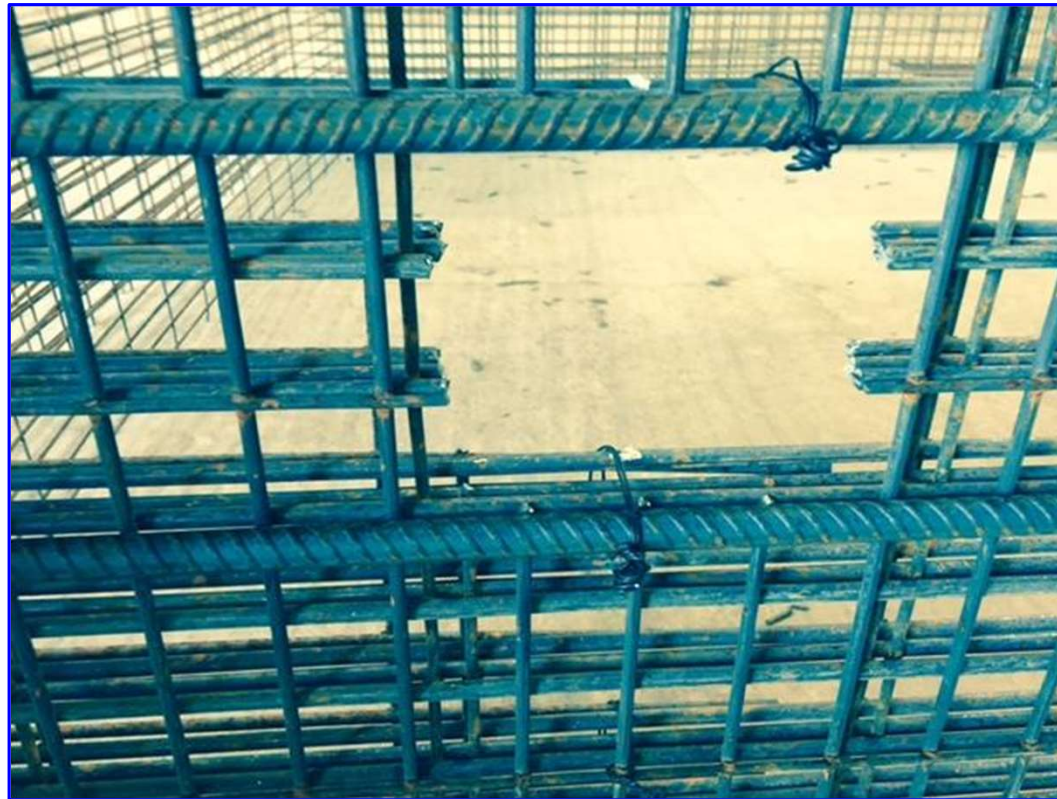



Plant Practices; Handling Holes:

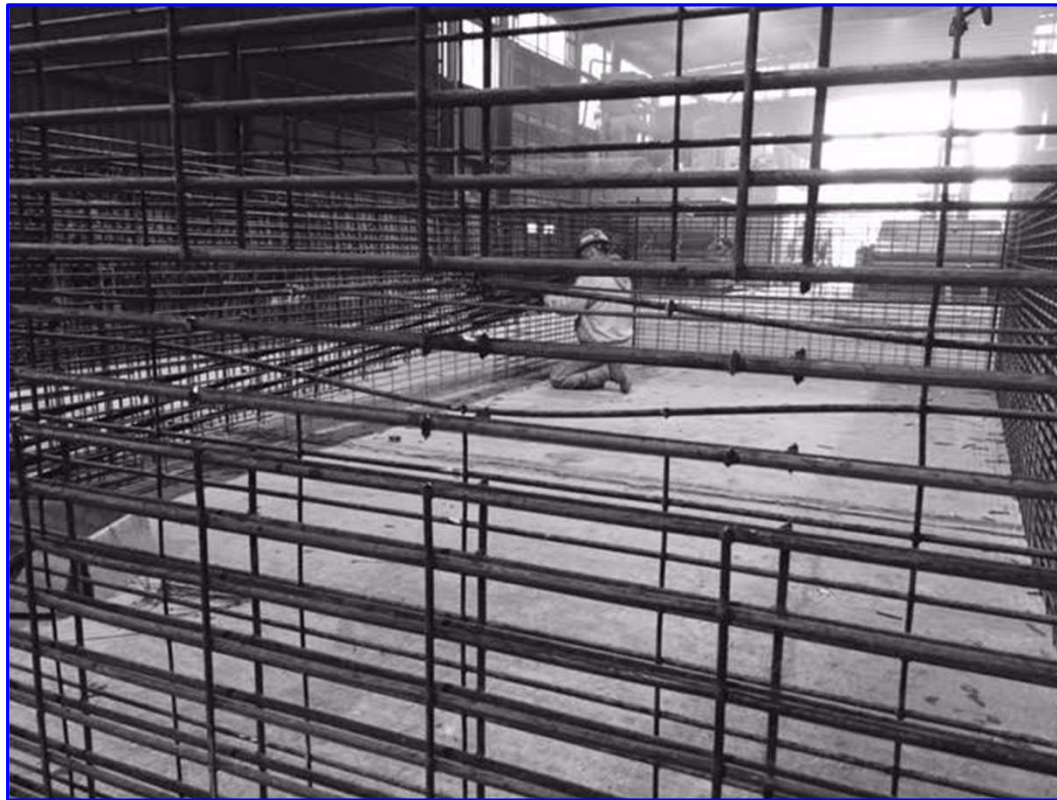





Cutting lift holes; how big can the hole be? **Contractor story.....**

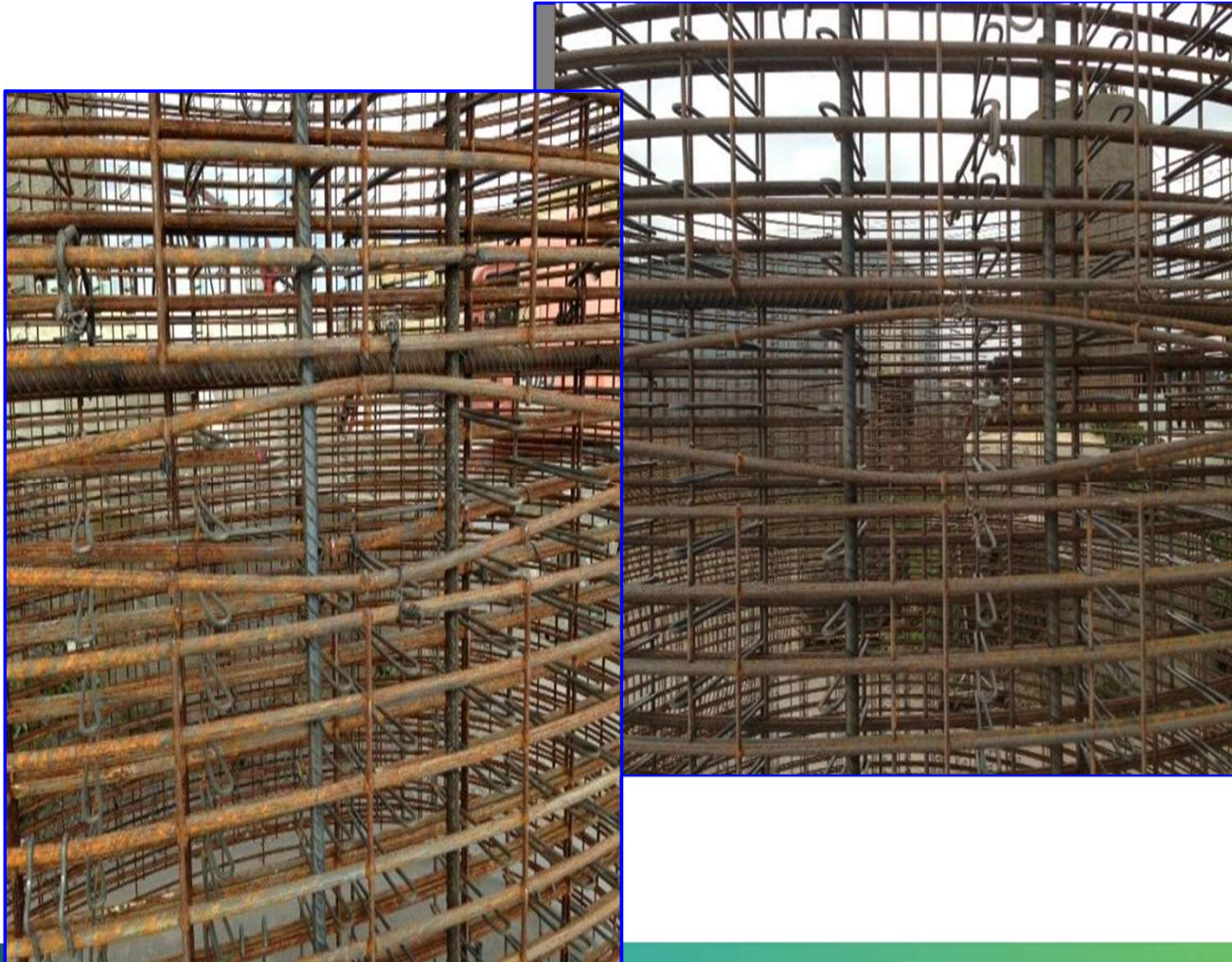

Lifting Devices





Splices & Laps

Section 8.1.8 States: **For PIPE, but this is important general knowledge!**

- If splices are not welded, the reinforcement shall be lapped not less than 20 Diameters for deformed bars and deformed cold worked wire, and 40 diameters for plain bars and cold drawn wire.
- In addition, where lapped cages of welded-wire fabric are used WITHOUT welding, the lap shall contain a longitudinal wire.
- Example: 20 diameter of a W8 wire which is .319" in diameter is 6.38" lap required.
- Example: 40 diameters of a W8 wire is 12.76" lap required. Both: including a Longitudinal wire.

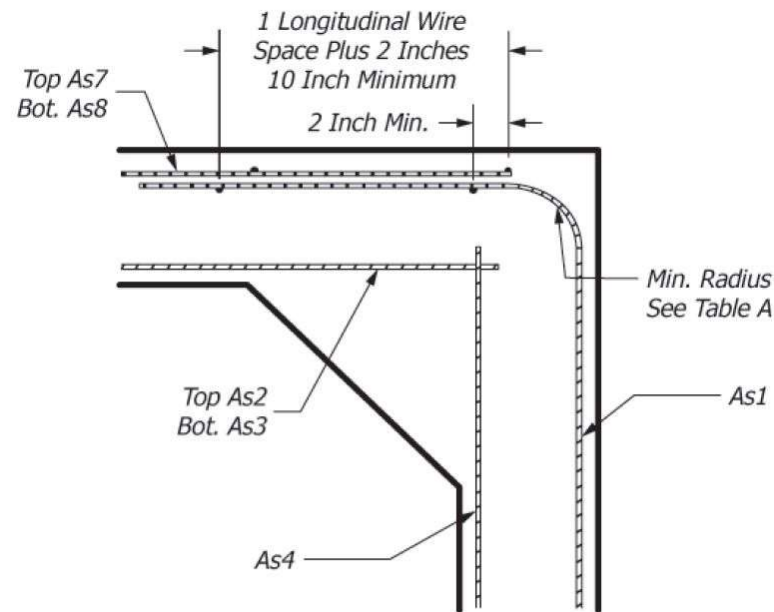

FIG. 5 Detailed Reinforcement Arrangement



- Another option, if you are using long enough laps and you don't have qualified welders, is to tie the lap with hog-nose rings, horizontal spacers from longitudinal to longitudinal, bag-ties or other mechanical fastening methods.
- Depending on the manufacturing process, you have to be very certain how rigid these connections are or they can come apart during the manufacturing of the pipe.
- With a proper lap and a secure tying system, this method will work just as well. However, just remember, it is NOT as strong as a welded cage for the pipe manufacturing process.
- Is a welded cage better than, worse or equal to a tied cage?





Welding: Splices & Laps

- Please take the time when you get back home from the Pipe School, to go to the [ACPA Members Only](#) section of their web site and download the **PROPER REINFORCING WELDING PRACTICES**.
- You will find a great amount of welding specifications, knowledge and **proof testing** on various wire sizes and various weld sizes and rod grades.
- You will also find some critical guidance on other welding we commonly consider doing in our Plants.



7.4 Laps, Welds, and Spacing—Splices in the circumferential reinforcement shall be made by lapping. The overlap measured between the outermost longitudinal wires of each reinforcement sheet shall not be less than the spacing of the longitudinal wires plus 2 in. but not less than 10 in. If As1 is extended to the middle of either slab and connected, welded splices are not prohibited in the connection. When used, As7 and As8 shall be lapped with As1 as shown in Fig. 5 or Fig. 6 (see also Fig. 7 and Fig. 8). If welds are made to circumferential reinforcement, they shall be made only to selected circumferential wires that are not less than 18 in. apart along the longitudinal axis of the box section. Also, when spacers are welded to circumferential wires, they shall be welded only to these selected circumferential wires. There shall be no welding to other circumferential wires, except it is not prohibited for As4 to be lapped and welded at any location or connected by welding at the corners to As2 and As3. No welds shall be made to As2 or As3 circumferential wires in the middle third of the span. (See Fig. 9 for welding restrictions.) When distribution reinforcement is to be fastened to a cage by welding, it shall be welded only to longitudinal wires and only near the ends of the box section. The spacing center to center of the circumferential wires shall not be less than 2 in. nor more than 4 in. The spacing center to center of the longitudinal wires shall not be more than 8 in.

ASTM C1577 - 20

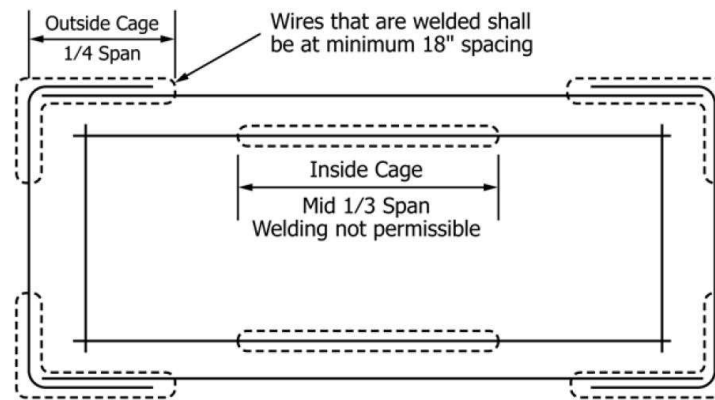

FIG. 15 Critical Zones of High Stress Where Welding is Restricted

Reference ASTM C-1433



- Welding on the reinforcing is critical to strength of the products we build. The weld can determine if our products pass the proof testing (3EB) in our Plants and is imperative to our products performing as they are designed to do in the field.
- **Welding is the most common problem area I find** in visiting pipe and box culvert manufacturing plants.....whether it is cage machines that are too hot, have missed the welding zone or manual welding done to our cages with a stick or wire feed welder, these welds have to be done well!
- **Poor welds is one thing I personally will never just walk by regardless of whose facility I am in.**
- Too many plants put their guy there that just doesn't seem to catch on anyplace else...wrong way! **Everyone should get experience, and in some cases, should start in the wire room to learn how critical cage making requirements and efforts are.**



Effects of Undercut

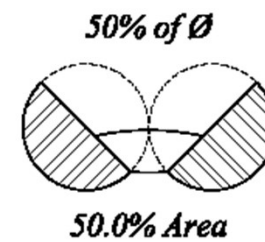
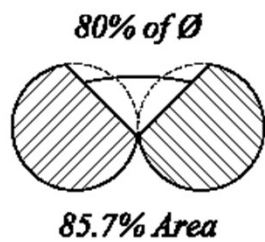
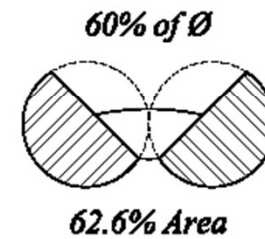
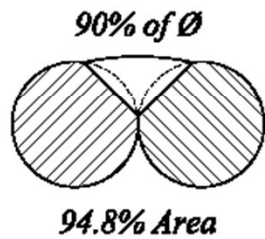
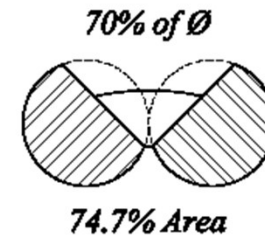
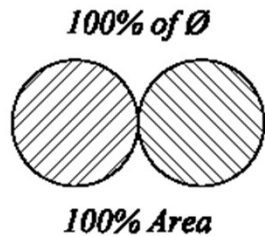





Plant Practices

- What do you do when you have a cage out of shape, from whatever cause?
- Do you use heat to re-shape the wire?

*Not unless you are trained and know how to measure the temperature of the steel and what temp is appropriate for the specific carbon content you are working with.



Look what happens to a very small wire like
a .120 area with 3" wire spacing.

= 4 wire per foot of pipe

= .03 sq in/ft

$(.03 \text{ sq in}) \times 75 \% \times 4 \text{ wires} = .0897 \text{ sq in/ ft}$

.120 sq in/ ft vs .0897 sq in/ft

Don't assume this poor job is consistently
done right; there could be less than 25% of
the product strength not delivered to the job
site due to careless work on OUR part.



Wire Size	Nominal Diameter	Actual Diameter	Area in ²	As (in ²) 3" oc	At 80% Diameter	As (in ²) 2" oc	At 80% Diameter
W3	0.195		0.0299	0.120	0.102	0.180	0.153
W4	0.226		0.0401	0.160	0.136	0.240	0.204
W6	0.276		0.0598	0.240	0.204	0.360	0.306
W8	0.319		0.0799	0.320	0.272	0.480	0.408
W10	0.357		0.1000	0.400	0.340	0.600	0.510
W12	0.391		0.1200	0.480	0.408	0.720	0.612
At 80% of the diameter, the loss due to a poor weld is ~85% of As.							



Ultimate Test Results w/6013 Welding Rod

W10 Smooth Welded Wire (Good Welds)								
Weld Length	Test #1 (Lbs)	Test #2 (Lbs)	Avg. (Lbs)	Nominal Dia. (in)	Actual Dia. (in)	Area (in ²)	50% of Yield (Lbs)	90% of Yield (Lbs)
Spot (Tack)	1600	1793	1697	0.357	0.357	0.100	3500	6300
1/4"	2944	2922	2933	0.357	0.357	0.100	3500	6300
3/8"	3167	3020	3094	0.357	0.357	0.100	3500	6300
1/2"	4031	4078	4055	0.357	0.357	0.100	3500	6300
3/4"	4905	4640	4773	0.357	0.357	0.100	3500	6300
1 1/4"	6540	6655	6598	0.357	0.357	0.100	3500	6300
W12 Smooth Welded Wire (Good Welds)								
Weld Length	Test #1 (Lbs)	Test #2 (Lbs)	Avg. (Lbs)	Nominal Dia. (in)	Actual Dia. (in)	Area (in ²)	50% of Yield (Lbs)	90% of Yield (Lbs)
Spot (Tack)	1608	2053	1831	0.389	0.391	0.120	4200	7560
1/4"	3735	4128	3932	0.389	0.391	0.120	4200	7560
3/8"	3855	4574	4215	0.389	0.391	0.120	4200	7560
1/2"	5366	5273	5320	0.389	0.391	0.120	4200	7560
3/4"	6239	6374	6307	0.389	0.391	0.120	4200	7560
1 1/4"	6694	7447	7071	0.389	0.391	0.120	4200	7560



Plant Practices



- All the topics we have previously discussed is information that all staff in your cage making crew needs to know.....**NOBODY can remember this all** and if they can, **Mr. Murphy** will have them someplace else, just when you need that experience the most.
- Keep records of all these options: **(for everyone's reference)**
- cage: height, squareness, area, preferred wire, design owner, ASTM Spec, wall thickness, spacer type, quantity and size, lap length, etc.....
- cage machine settings at end of each run
- results of QC checks for consistency verification
- **ELIMINATE ANY AND ALL GUESSWORK!**
- **This record keeping is a great way to train new employees. By their starting in cage production, they are trained in the importance of this part of the operation and it introduces them into the Plant work environment before working in the potentially more dangerous production areas.....for safety reasons.**



Plant practices

- What are some ways to know you are making a quality cage?
- After rolling your cage, check your length and squareness of the cages to see that you are in spec.
- When the cage makes it to the production floor, see how the cage sets on the pallet, inside the jacket and around the core. Make adjustments if needed.
- After the box culvert is poured, **check the box** for any cracks, slabbing or protruding reinforcement.
- Finally, after the box has been cured, **check it again** for cracks, slabbing or protruding reinforcement.



Section 9.3; Joint Reinforcement:

- Outer cage circumferential reinforcement as shown in Figs. 1 and 2 shall be placed in the top and bottom slabs at the groove portion of the joint when As1 is **NOT continuous over the span**.
- The minimum area of such reinforcement in **square inches per linear foot** of box section length shall be the same as the areas specified for As4 in Tables 1 and 2.

Plus previous comments included in Section 7.3 stating it must be in the tongue and the groove portion of the joint.

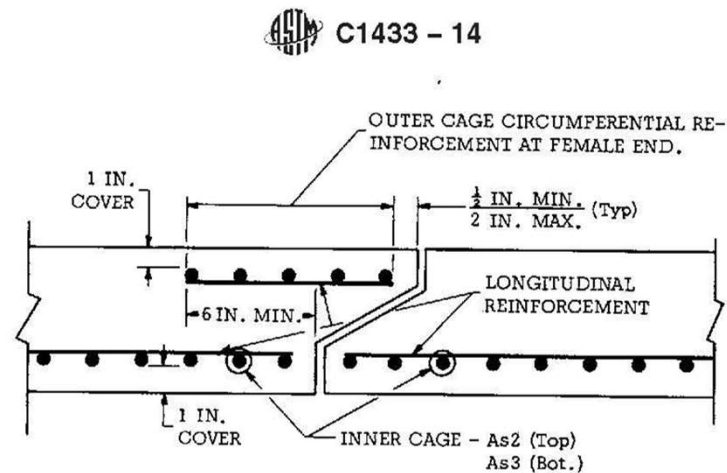

FIG. 2 Section A-A Top and Bottom Slab Joint Reinforcement



- **NEW: Section 12.5.1; Joint Reinforcement in Rubber Gasket Joints**
- Same as is in our PIPE Specifications!
- *12.5.1 Joint Reinforcement for Rubber Gasket Joints*—In no case, however, shall the cover over the reinforcement be less than 1/4 in. as measured to the end of the spigot or 1/2 in. as measured to any other surface.



Cover.....Concrete Cover

Concrete Cover definition: Per ACI Part 3, Section R7.7 (since there is **no ASTM C822** definition)

- Concrete Cover is a protection of reinforcement against weather and **other effects**
- Concrete Cover is measured from the CONCRETE SURFACE to the OUTERMOST SURFACE of the STEEL to which the COVER **requirement applies.**
- This is in compliance with all the previous specifications we just reviewed.
- Proper cover in all areas: bell, haunch, barrel, shoulder, spigot.
- **This is a major cause of dry cast box culvert wall slab offs!**

Some of our members may have references to CLEAR COVER or other terms that work for their operation. The specifications we are reviewing today do not make such reference, however, CLEAR COVER can best be illustrated as **the thickness of a block that you can slip between the wire cage and the core or jacket** (surface of the concrete).



C1577, Section 7.3; Note 4

Not in C1433! NO LONGER IN C1577 either. HISTORY!

- Note 4:
- Depending on reinforcement layout, some designs may fail to meet the provisions in the AASHTO LRFD Bridge Design Specifications that **the concrete cover be at least three time the reinforcing diameter**. Since the introduction of Specification C789 for Precast Reinforced Concrete Box Sections for Culverts, Storm Drains, and Sewers in 1974, the ASTM and AASHTO Materials Standards for precast box culverts have all utilized 1" of concrete cover over the reinforcement. Boxes manufactured in accordance with the ASTM and AASHTO Material Standards **have performed well over the years, with no indication of distress resulting from the 1" concrete cover**.



Plant Practices; Layers of Wire Mats:

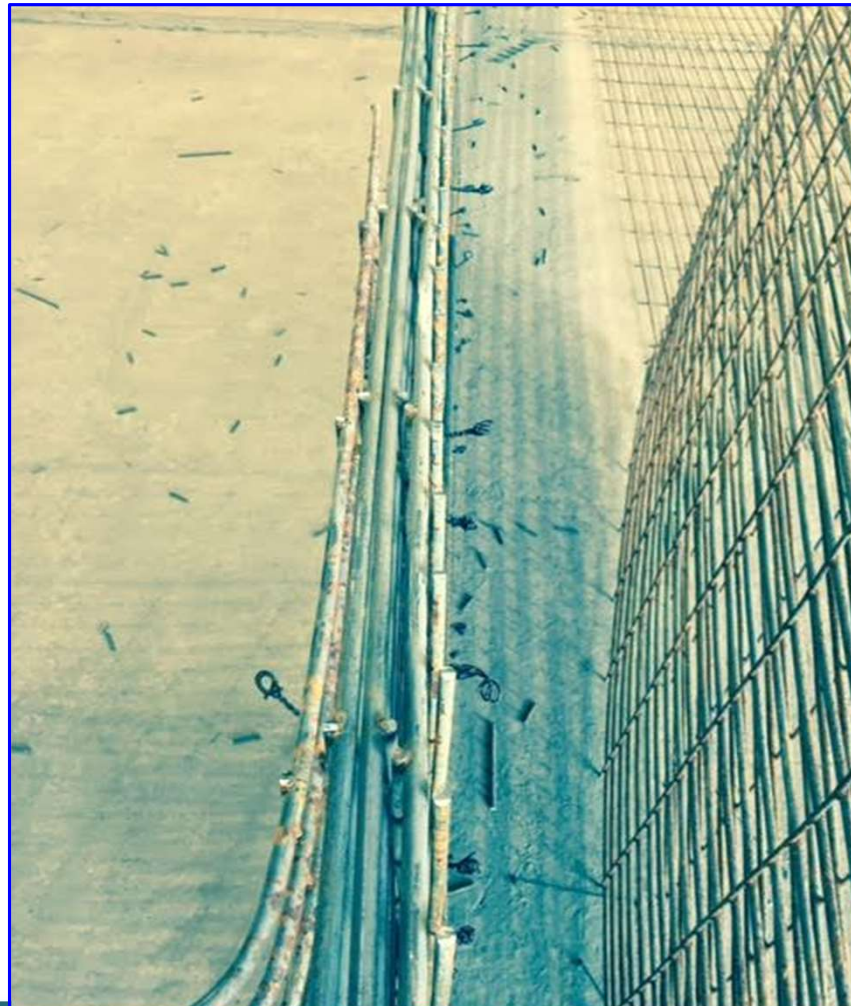



Why is Concrete Cover Important?

- ❑ Concrete: Cracking, Spalling, & Slabbing
- ❑ Steel: weakened from exposure to the environment (shadowing)
- ❑ Overall effect: lost of structural integrity



SHADOWING



SLABBING



Methods to Obtain Proper Concrete Cover

- Cage positioners
- Spacers **How do you pick the right spacer for different cages? One Line? How many Layers? How many forms?**
- Cutting and bending transverse wires - not recommended





Plant Practices: Concrete Cover; Assurance

#3 bar “X” pattern in ALL corners of the box, only welding to the transverse bars on the cage. This stabilizes the wire for transporting the cage to the form.





Plant Practices; Concrete Cover: Assurance





Plant Practices; Concrete Cover: Assurance:

“When welding the laps on the cage, tack weld starting on the bottom of the inner cage to the designed measurement and then move to the top (from the ground up...not box top or bottom) of the cage and do the same tack welding.”

“Then we bag tie the seam between these welds which are allowed in ASTM but we try to do as few as possible.”

“Then we repeat the process for the outer cage.”

A little MORE help from our friends: There are two powerpoint presentations in the back Appendix from previous classes that were generated by the people at CAM.....Thank you.



Plant Practices; Concrete Cover: Assurance:



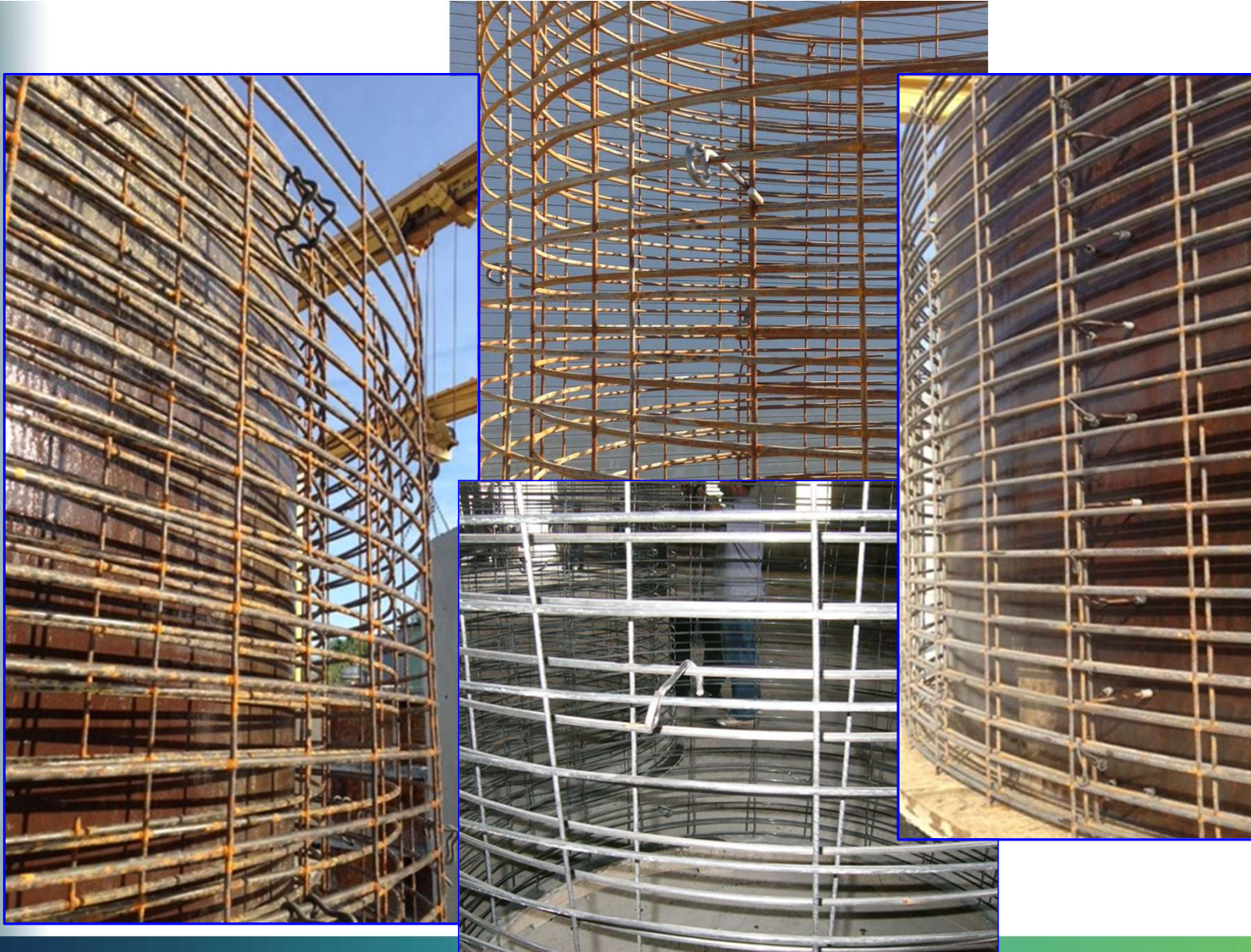

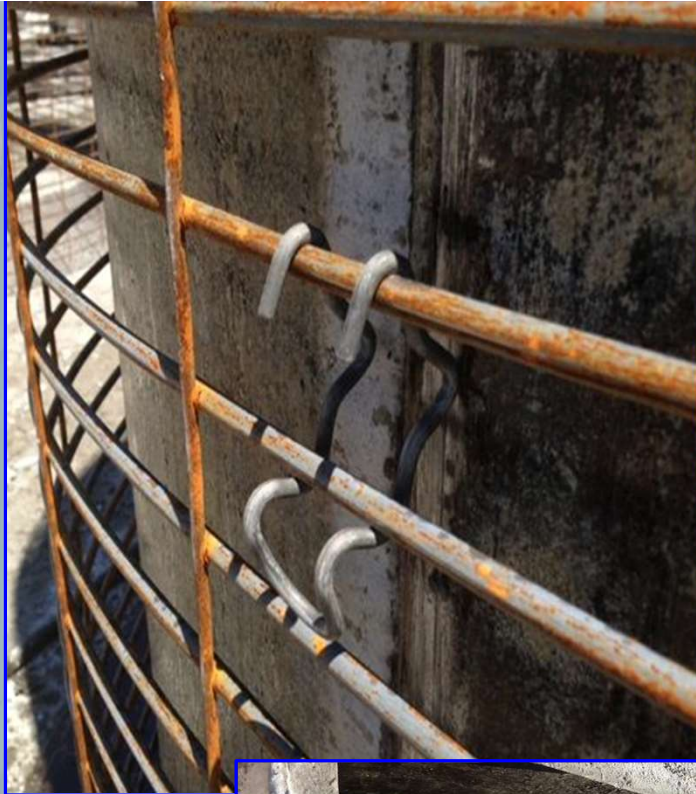





WHY it matters!









Plant Practices; Spacer Use:

Suggestions from **David Swenson, a spacer supplier at Eastern States Steel**: “**The rule of thumb is one box spacer every 2 square feet (every 17”)**”. This is a very conservative guide and is dependent on how well the cages are formed and the quality of the mesh. From my travels, I’ve seen an extremely wide range of spacer usage, both plastic and steel, in box culvert including tack welding pieces of rebar as a spacer. I am not aware of any “standard” for spacer placement in box culverts.”

Northern WET CAST practices:

1. Square up your OUTER wire as best you can, then start putting the proper size pins (box cage spacers) in. Start off the bottom of the cage at least **2” off the edge of the haunch with no more than 36” between pins**. Typically for an 8’ high box section we run **4 rows of pins equally spaced**. We then tie all the pins up inside and outside the cage.
2. Then, we **put clips in between the pins** to hold the cover accurately. In between every row of pins you put clips to hold the **1” cover**. You do this inside and outside the cage.

Methods to Obtain Proper Concrete Cover

- ❑ Places the steel reinforcement in the proper location required to meet structural design, during the casting operation.

Types of Reinforcement Spacers

- ❑ Single Cage



- ❑ Double Cage



Types of Reinforcement Spacers

Box Culvert



Heavy Duty





Plant Practices; Spacer Use

How Many Spacers are Required on a cage?

- The next 4 slides are commonly used practices for spacer placement. **This goes by your plant experience, even the suppliers have varying recommendations.**
- The manufacturing process, the **stiffness of the cage and the size of the product all are determining factors** in how many you should use.
- I can tell you that in large products with relatively heavy wire manufactured by the dry cast method, we have found that three rows at around **32" maximum distance** in the circumferential and vertical direction is a good number to have a great finished product.
- In the information at the back of the room from our **ACPA Associate sponsors**, there is a great deal of information on the various types of products available to properly position our cages in the many different production methods that we use.





Spacers....Cage Positioners....Cage Mounted Types



STANDARD PLACEMENT OF SPACERS FOR SINGLE CAGE PIPE

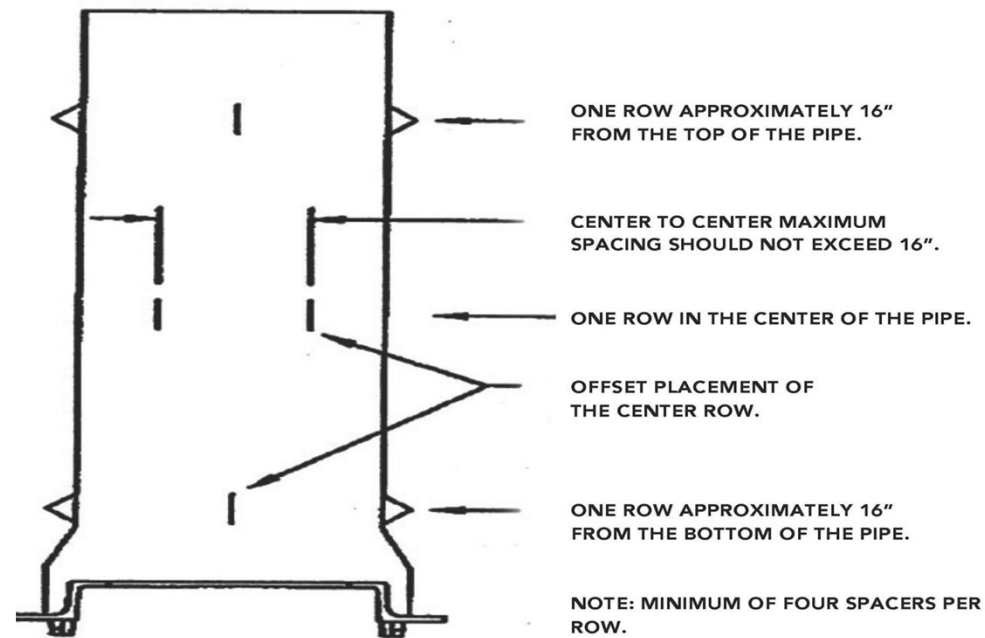



Spacers....Cage Positioners....Cage Mounted Types

MINIMUM PLACEMENT OF SPACERS FOR SINGLE CAGE PIPE

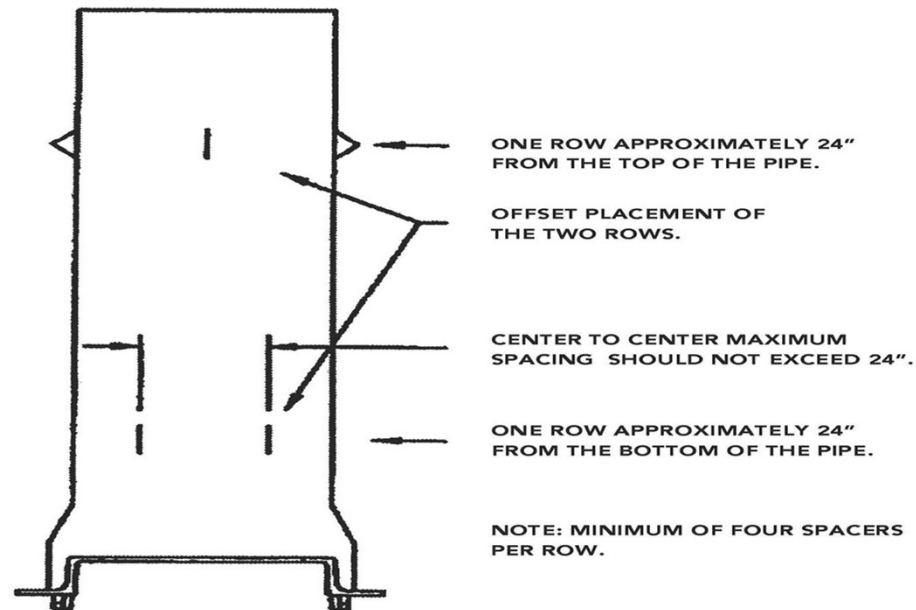

NOTE: THE MINIMUM PLACEMENT OF SPACERS FOR SINGLE CAGE PIPE MAY BE USED IF CAGE ROUNDNESS IS VERY GOOD. THREE EDGE BEARING TESTING MUST BE DONE TO INSURE THAT THE LOCATION OF THE STEEL REINFORCEMENT MEETS ASTM C-76 SPECIFICATION.

OCTOBER 1998



Spacers....Cage Positioners....Cage Mounted Types



STANDARD PLACEMENT OF SPACERS FOR DOUBLE CAGE PIPE

ONE ROW APPROXIMATELY 16" FROM THE TOP OF THE PIPE.

CENTER TO CENTER MAXIMUM SPACING SHOULD NOT EXCEED 16".

ONE ROW IN THE CENTER OF THE PIPE .

OFFSET PLACEMENT OF THE CENTER ROW.

ONE ROW APPROXIMATELY 16" FROM THE BOTTOM OF THE PIPE.

NOTE: MINIMUM OF FIVE SPACERS PER ROW.

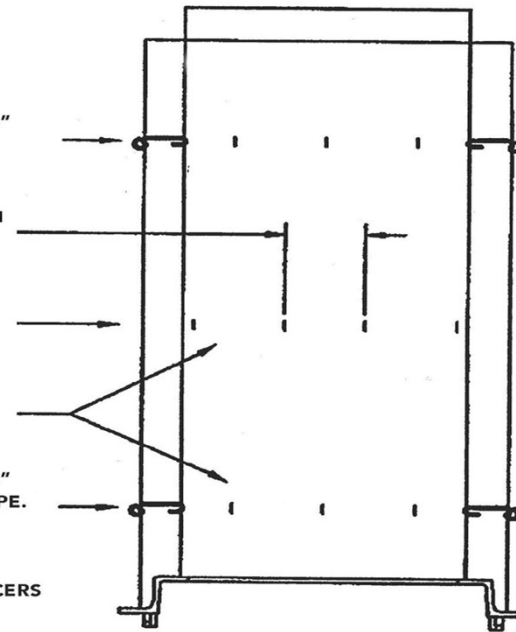



Spacers....Cage Positioners....Cage Mounted Types



MINIMUM PLACEMENT OF SPACERS FOR DOUBLE CAGE PIPE

ONE ROW APPROXIMATELY 24"
FROM THE TOP OF THE PIPE.

OFFSET PLACEMENT OF
THE TWO ROWS.

CENTER TO CENTER MAXIMUM
SPACING SHOULD NOT
EXCEED 24".

ONE ROW APPROXIMATELY 24"
FROM THE BOTTOM OF THE PIPE.

NOTE: MINIMUM OF FOUR
SPACERS PER ROW.

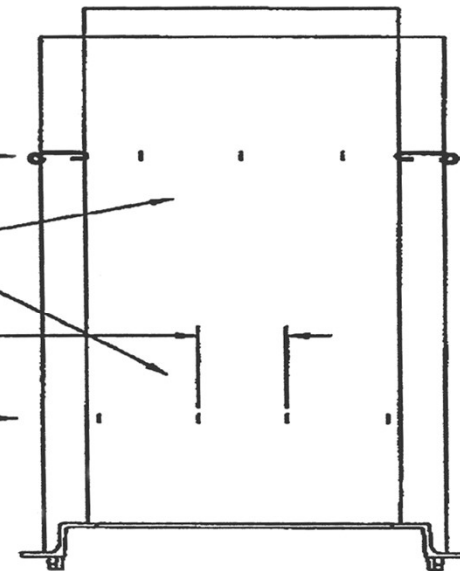

NOTE: THE MINIMUM PLACEMENT OF SPACERS FOR DOUBLE CAGE PIPE MAY BE USED IF CAGE ROUNDNESS IS VERY GOOD. THREE EDGE BEARING TESTING MUST BE DONE TO INSURE THAT THE LOCATION OF THE STEEL REINFORCEMENT MEETS ASTM C-76 SPECIFICATION.

OCTOBER 1998



Plant Practices; Placement of Reinforcement:

Example: 8' x 6' Box Culvert w/ 8" Walls Using ASTM C-1577 and 15' Of Cover

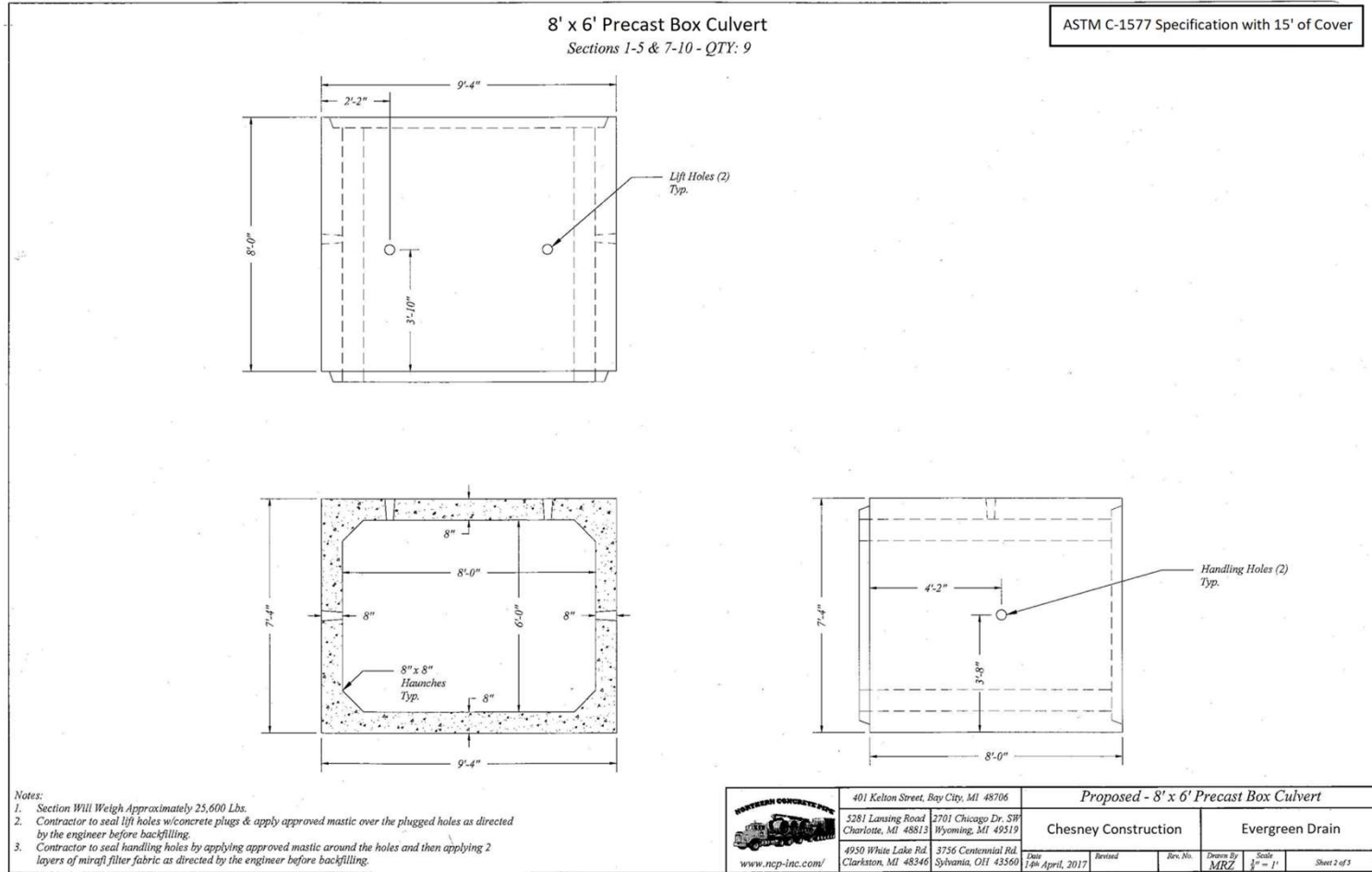



Plant Practices; **Placement of Reinforcement:**
 ASTM C-1577 Specification for 8' x 6' Box Culvert w/ 8" Walls



8 ft by 6 ft by 8 in.

Design Earth Cover, ft	Circumferential Reinforcement Areas, in. ² /ft							"M," in.
	A _{s1}	A _{s2}	A _{s3}	A _{s4}	A _{s5}	A _{s7}	A _{s8}	
0<2	0.22	0.42	0.35	0.19	0.19	0.19	0.19	
2<3	0.25	0.40	0.38	0.19				50
3-5	0.21	0.32	0.33	0.19				50
10	0.22	0.33	0.34	0.19				45
15	0.28	0.43	0.45	0.19				41
20	0.36	0.55	0.57	0.19				41



Inner Cage

As5

As2, 3, 4

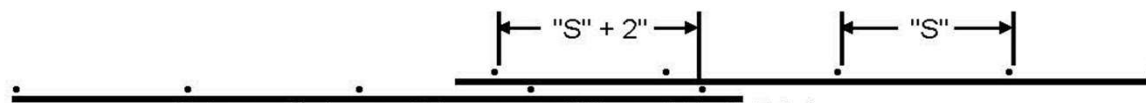
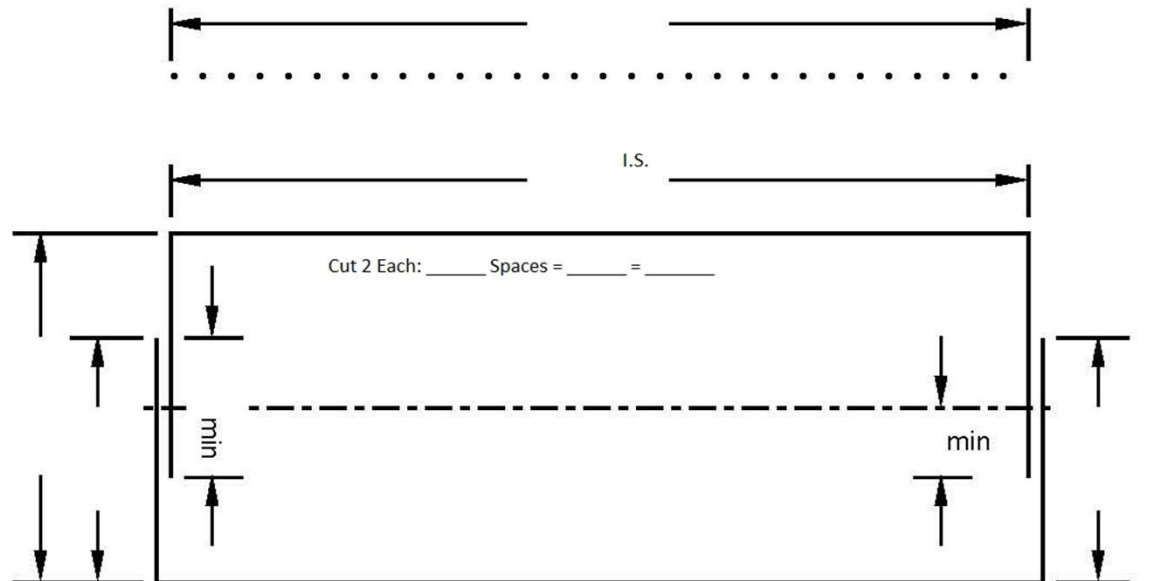

Between Outermost Transverse Wires of Each Fabric Sheet Shall Not Be Less Than The Spacing + 2"
Typical Lap Detail



Calculations

O.S. $8' \text{ Span} + 8'' \text{ Wall} + 8'' \text{ Wall} - 2'' \text{ Cover} = 9'-2'' \text{ O.S.}$
 $6' \text{ Rise} + 8'' \text{ Wall} + 8'' \text{ Wall} - 2'' \text{ Cover} = 7'-2'' \text{ O.S.}$

Lap $9'-2'' / 2 = 4'-7'' + 10'' \text{ Min.} = 5'-5'' \text{ Min.}$

Wire Length $7'-2'' + 5'-5'' + 5'-5'' = 18'-0''$
 $18'-0'' = 216'' / 8'' \text{ Spacing} = 27 \text{ Spaces}$

Note: The overall wire length is to be adjusted by + 4" to avoid bending on a transverse wire.
Northern's practice is to add a space = 8"

I.S. $8' \text{ Span} + 2'' \text{ Cover} = 8'-2'' \text{ I.S.}$
 $6' \text{ Rise} + 2'' \text{ Cover} = 6'-2'' \text{ I.S.}$

Lap $6'-2'' / 2 = 3'-1'' + 10'' \text{ Min.} = 3'-11'' \text{ Min.}$

Wire Length $8'-2'' + 3'-11'' + 3'-11'' = 16'-0''$
 $16'-0'' = 192'' / 8'' \text{ Spacing} = 24 \text{ Spaces}$

Note: The overall wire length is to be adjusted by + 4" to avoid bending on a transverse wire.
Northern's practice is to add a space = 8"

7.4 Laps, Welds, and Spacing—Splices in the circumferential reinforcement shall be made by lapping. The overlap measured between the outermost longitudinal wires of each reinforcement sheet shall not be less than the space containing two longitudinal wires of each mesh plus 2 in., but not less than 10 in. If A_{s1} is extended to the middle of either slab and connected, welded splices or lapped splices shall be used in the connection. When used, A_{s7} and A_{s8} shall be lapped with A_{s1} as shown in Fig. 5, Fig. 6, or Fig. 8 and are not prohibited from being connected by welding. If welds are made to circumferential reinforcement, they shall be made only to selected circumferential wires that are not less than 18 in. apart along the longitudinal axis of the box section as shown in Fig. 9. Also, when spacers are welded to circumferential wires, they shall be welded only to these selected circumferential wires. There shall be no welding to other circumferential wires, except A_{s4} is not prohibited from being lapped and welded at any location or connected by welding at the corners to A_{s2} and A_{s3} . No welds shall be made to A_{s2} or A_{s3} circumferential wires in the middle third of the span as shown in Fig. 9. When distribution reinforcement is to be fastened to a cage by welding, it shall be welded only to longitudinal wires and only within 18 in. of the end of the box section. If welds are made



By: Northern Concrete Pipe, Inc.

State Tested: Yes

Contractor: Chesney Construction Job: Evergreen Drain Location: Bay County
 Span: 8' Rise: 6' Length: 76'-4" Spec: ASTM C-1577 HL-93 W/ 15' Cover Design By: _____
 Top: 8" Bottom: 8" Walls: 8" Haunches: 8" x 8" Min Cover: 1" Max Cover: 15"
 # Pcs.: 10 Pieces Inspection By: Department Of Transportation 5000 psi Concrete Yes Air Ent.

Minimum Area (in²/ft)
 Concrete Cover (in)

As1	As2	As3	As4	As7	As8	As5	As6	As1 Ext.
.280	.430	.450	.190	.190	.190	X	X	
1"	1"	1"	1"	1"	1"	X	X	

Outer Cage

As7, 8

.190 = .240

As1

.280 = .300

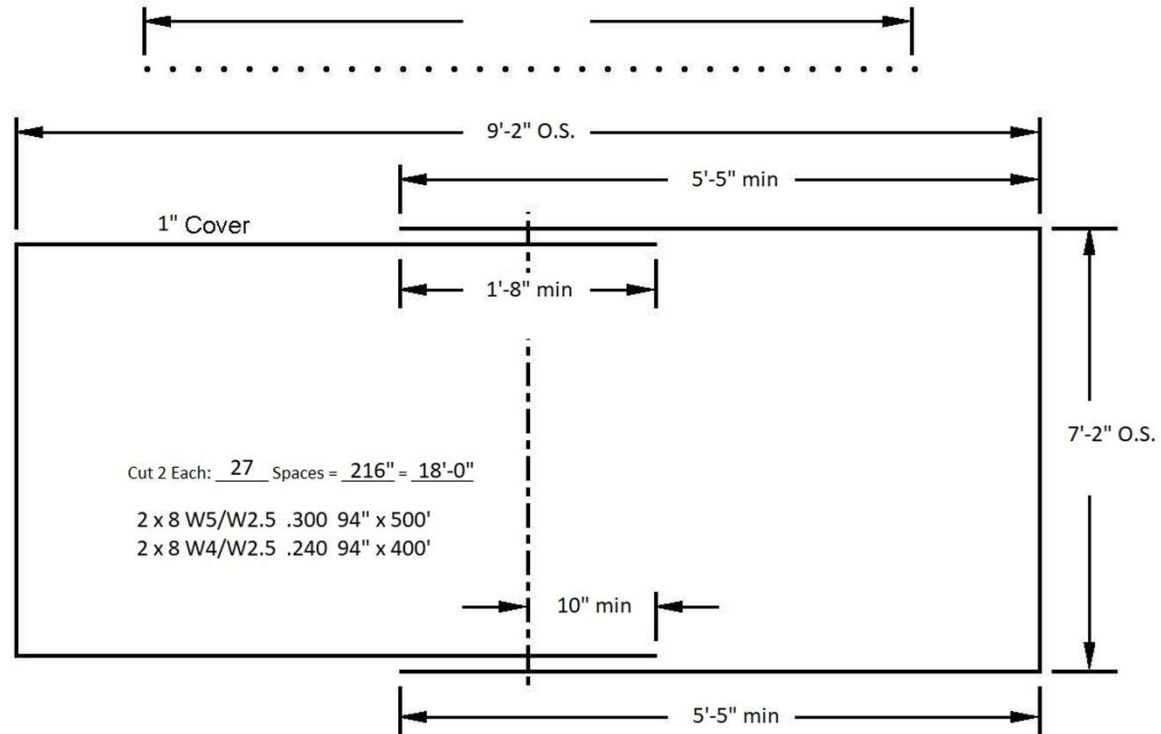



Inner Cage

As 4

.190 = .240

As 3

.450

As 2

.430 = .450

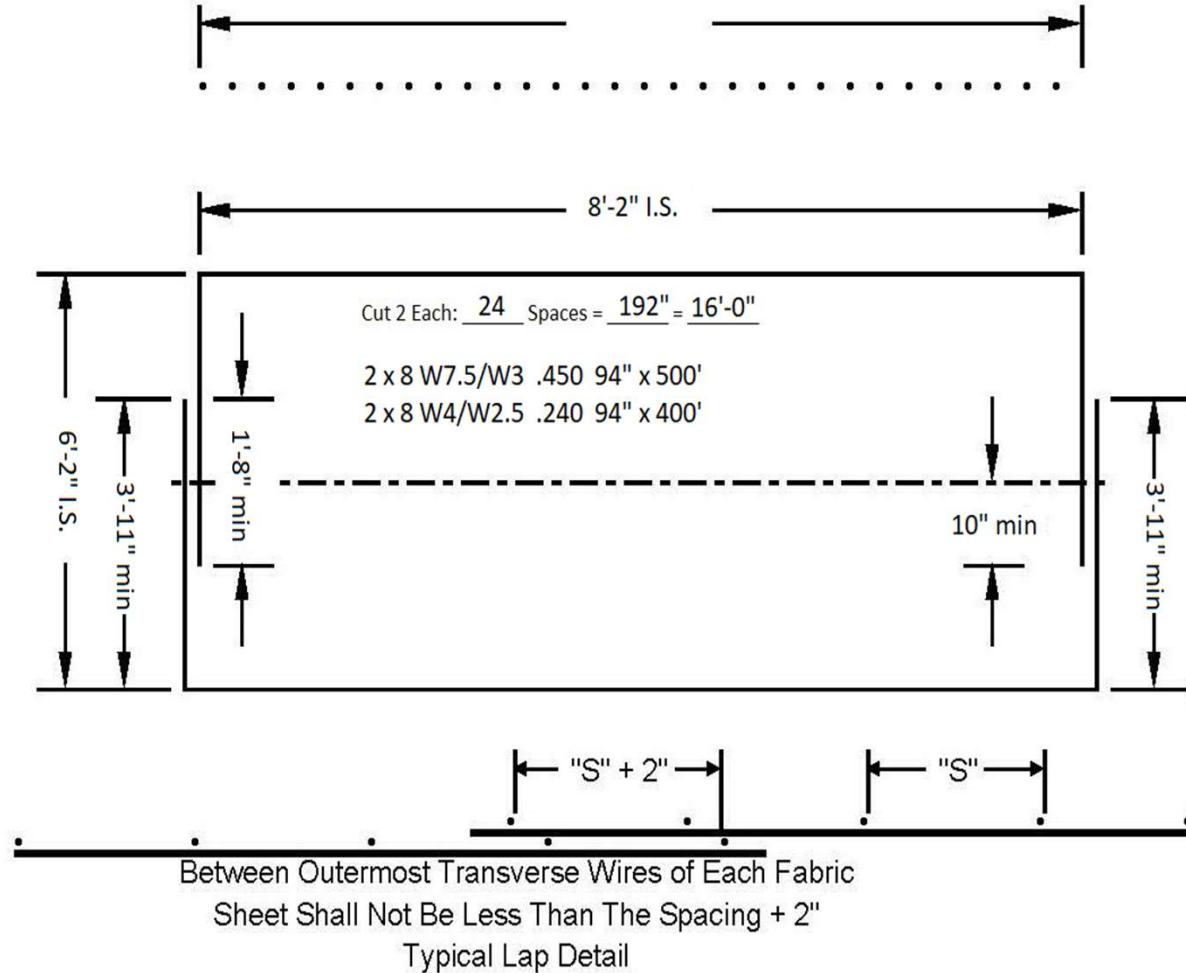



Plant Practices; Placement of Reinforcement:

Example: 10' x 5' Box Culvert w/ 10" Walls Using ASTM C-1577 And 2'-3' of Cover

Section #3-14

(12 Required)

10' x 5' x 8' Precast Box Culvert
ASTM C-1577 Specification with 2'-3' Of Cover

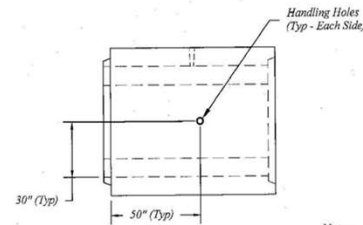
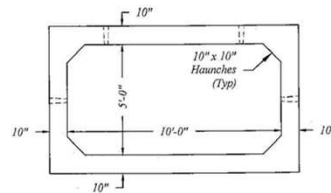
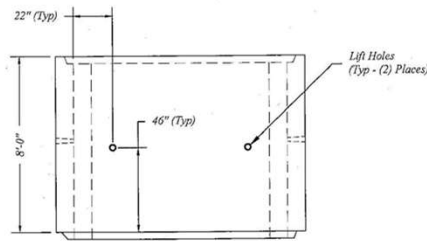

Section Will Weigh Approximately 35,000 lbs.

Notes:

1. Box Sections Shall Be Manufactured w/ Tapering Lift Holes; Therefore Requiring Cables of Proper Capacity & Length For Safe Unloading & Installation. (Detail on Sheet #11)
2. Contractor To Seal Lift Holes & Handling Holes w/ Concrete Plugs & Apply Approved Mastic Over The Plugged Holes As Directed By The Engineer Before Backfilling.

Approved By: _____
 Company Name: _____
 Date Approved: _____

2381 Lem's Road Knoxville, TN 37919 Ph: (615) 644-2777	3756 Commercial Blvd Knoxville, TN 37919 Ph: (615) 841-3361	407 Adams Knoxville, TN 37919 Ph: (615) 852-3545
Revisions: No. 1 Date: 1/5/17	Sheet Title: Section #3-14	Moore County Tennessee Daniel's Road Crossing CUSTOMER: Lem's Excavating
Drawn By: BCK	Scale (11" x 17"): 1/4" = 1'-0"	Date: 12/12/16
Checked By:	Sheet No.: 7	13



Plant Practices; **Placement of Reinforcement:**
 ASTM C-1577 Specification for 8' x 6' Box Culvert w/ 8" Walls



10 ft by 5 ft by 10 in.

Design Earth Cover, ft	Circumferential Reinforcement Areas, in. ² /ft							"M," in.
	A _{s1}	A _{s2}	A _{s3}	A _{s4}	A _{s5}	A _{s7}	A _{s8}	
0<2	0.30	0.36	0.30	0.24	0.24	0.24	0.24	
2<3	0.35	0.39	0.34	0.24				58
3-5	0.28	0.31	0.30	0.24				53
10	0.33	0.35	0.36	0.24				52
15	0.42	0.46	0.47	0.24				47
20	0.55	0.59	0.61	0.24				47
25	0.68	0.73	0.75	0.24				47



By: Northern Concrete Pipe, Inc. State Tested: Yes
 Contractor: Lem's Excavating Job: Daniel's Road Crossing Location: Moore County
 Span: 10' Rise: 5' Length: 115'-6" Spec: C-1577 HL-93 W/ 2'-3' Cover Design By: _____
 Top: 10" Bottom: 10" Walls: 10" Haunches: 10" x 10" Min Cover: 1" Max Cover: 2'-3' Cover
 # Pcs.: 15 Pieces Inspection By: Department Of Transportation 5000 psi Concrete Yes Air Ent.

	As1	As2	As3	As4	As7	As8	As5	As6	As1 Ext.
Minimum Area (in ² /ft)									
Concrete Cover (in)									

Outer Cage

As6

As7

As1

As8

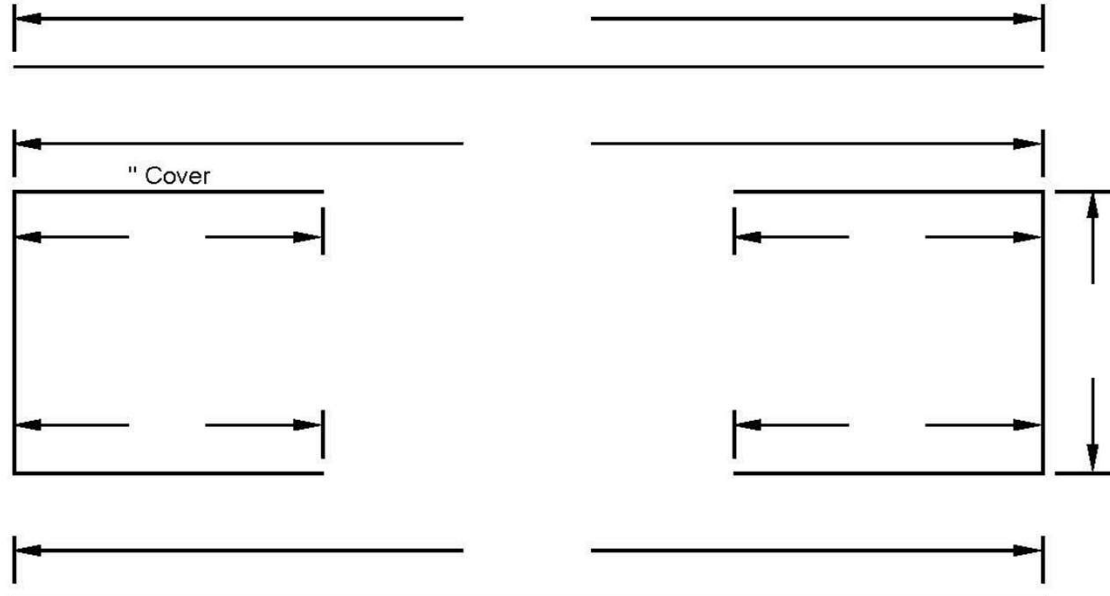



Inner Cage

As5

As2

As4

As3

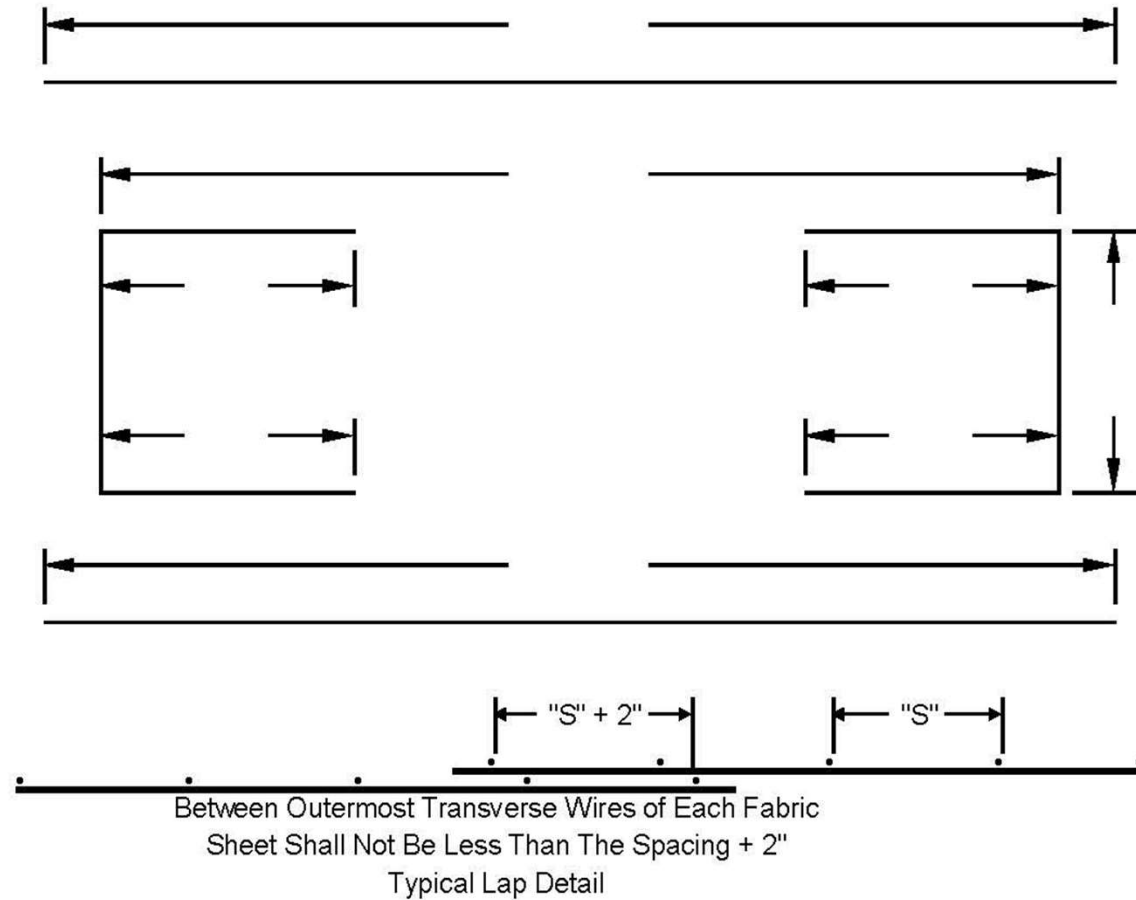

Between Outermost Transverse Wires of Each Fabric
Sheet Shall Not Be Less Than The Spacing + 2"

Typical Lap Detail



Calculations

O.S. 10' Span + 10" Wall + 10" Wall - 2" Cover = 11'-6" O.S.
 5' Rise + 10" Wall + 10" Wall - 2" Cover = 6'-6" O.S.
 10' Span + 4" Min. + 4" Min. = 10'-8" O.S.
 See Fig 3

Wire Length 6'-6" + 5'-1" + 5'-1" = 16'-8"
 16'-8" = 200" / 8" Spacing = 25 Spaces

10'-8" = 128" / 8" Spacing = 16 Spaces

Note: The overall wire length is adjusted by + 4" to avoid bending on a transverse wire.
 Northern's practice is to add a space = 8"

I.S. 5' Rise + 2" Cover = 5'-2" I.S.
 10' Span + 4" Min. + 4" Min. = 10'-8" I.S.
 See Fig 3

Wire Length 5'-2" + 1'-9" + 1'-9" = 8'-8"
 8'-8" = 104" / 8" Spacing = 13 Spaces
 10'-8" = 128" / 8" Spacing = 16 Spaces

Note: The overall wire length is adjusted by + 4" to avoid bending on a transverse wire.
 Northern's practice is to add a space = 8"

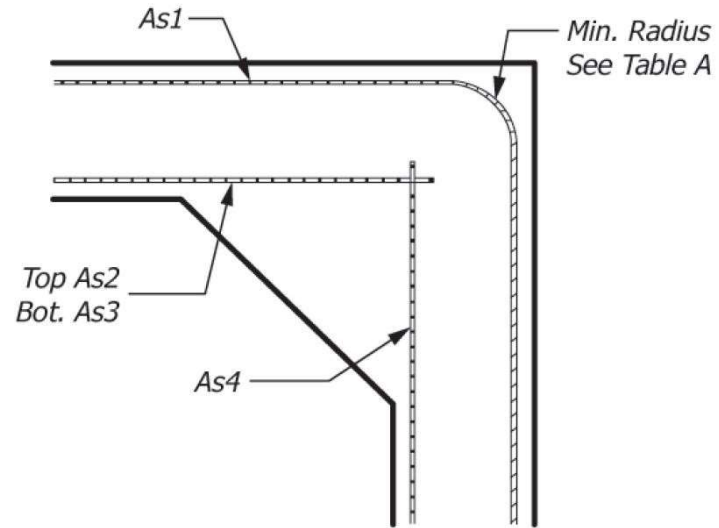

FIG. 3 Detail Inner Reinforcement



By: Northern Concrete Pipe, Inc.

State Tested: Yes

Contractor: Lem's Excavating Job: Daniel's Road Drain Location: Moore County
 Span: 10' Rise: 5' Length: 115'-6" Spec: C-1577 HL-93 W/ 2'-3' Cover Design By: _____
 Top: 10" Bottom: 10" Walls: 10" Haunches: 10" x 10" Min Cover: 1" Max Cover: 2'-3' Cover
 # Pcs.: 15 Pieces Inspection By: Department Of Transportation 5000 psi Concrete Yes Air Ent.

	As1	As2	As3	As4	As7	As8	As5	As6	As1 Ext.
Minimum Area (in ² /ft)	.350	.390	.340	.240	.240	.240	X	X	
Concrete Cover (in)	1"	1"	1"	1"	1"	1"	X	X	

Outer Cage

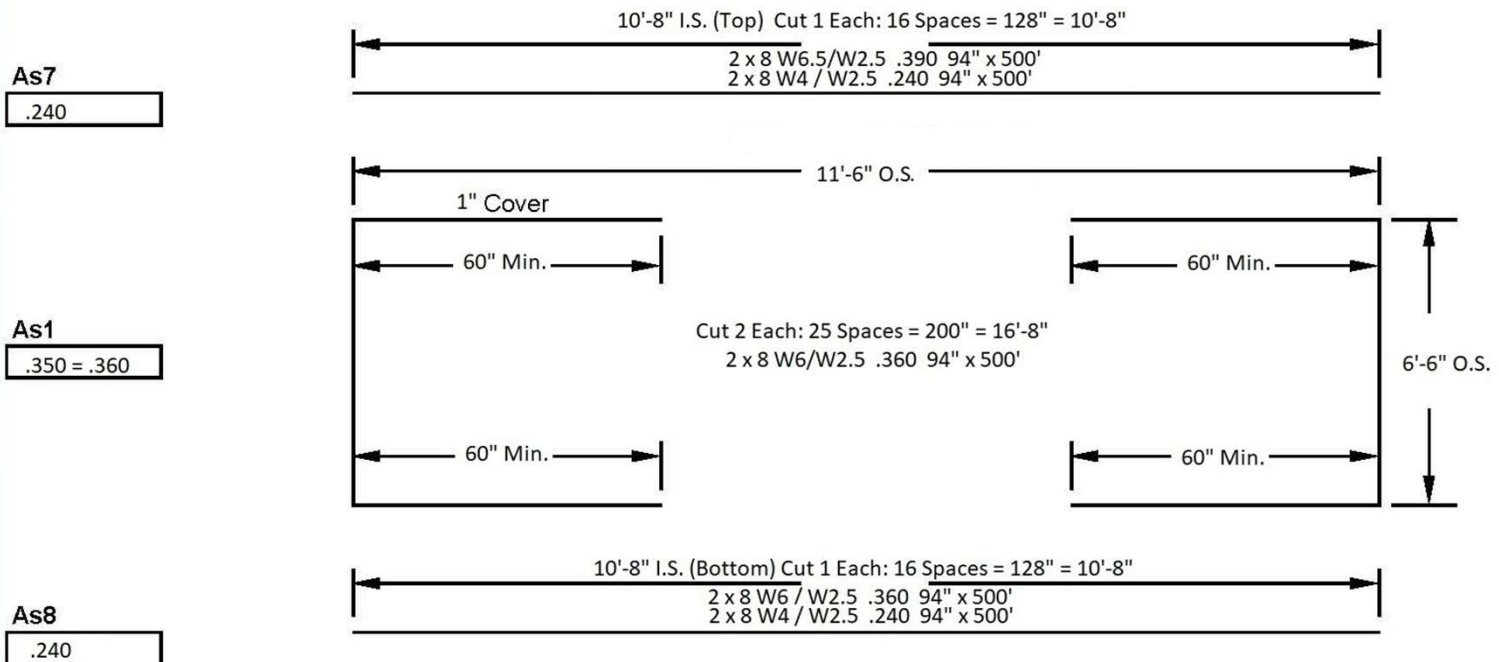



Inner Cage

As2

.390

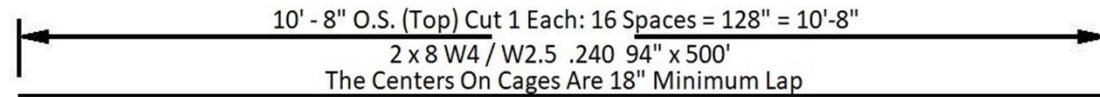

As4

.240

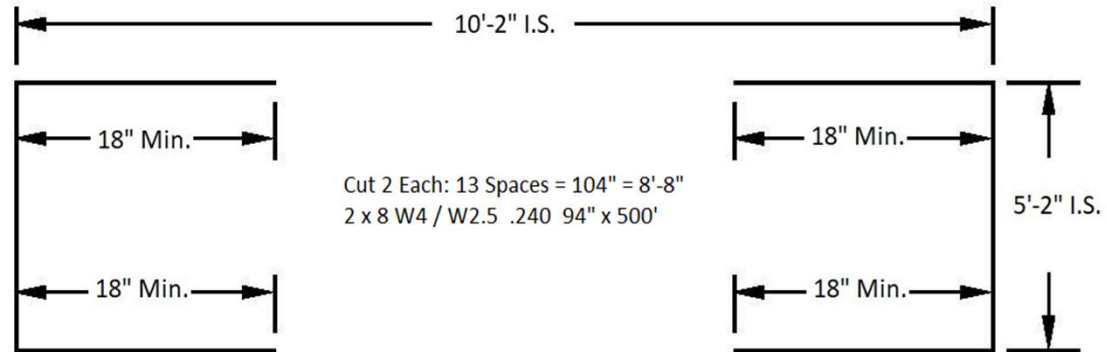

As3

.340 = .360

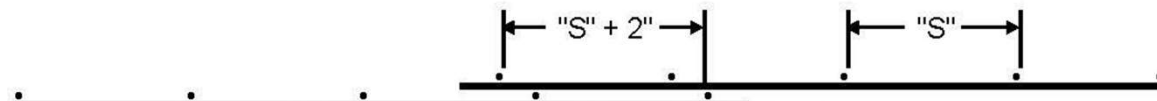
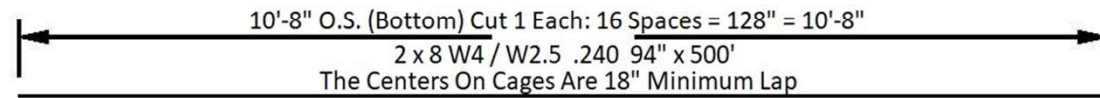

Between Outermost Transverse Wires of Each Fabric Sheet Shall Not Be Less Than The Spacing + 2"
Typical Lap Detail



Area	Description	Lbs/LF
0.220	3x8 W5.5/W2.5 93" x 400'	6.99
0.240	2x8 W4/W2.5 94" x 400'	7.60
0.260	3x8 W6.5/W2.5 93" x 400'	8.42
0.270	2x8 W4.5/W2.5 94" x 400'	8.40
0.300	2x8 W5/W2.5 94" x 400'	9.20
0.330	2x8 W5.5/W2.5 94" x 400'	10.00
0.360	2x8 W6/W2.5 94" x 400'	10.80
0.390	2x8 W6.5/W2.5 94" x 400'	11.60
0.420	2x8 W7/W3 94" x 400'	12.60
0.450	2x8 W7.5/W3 94" x 400'	13.50
0.480	2x8 W8/W3.5 94" x 400'	14.50
0.510	2x8 W8.5/W3.5 94" x 400'	15.30
0.540	2x8 W9/W4 94" x 400'	16.30
0.570	2x8 W9.5/W4 94" x 400'	17.10
0.600	2x8 W10/W4 94" x 400'	18.00
0.630	2x8 W10/W4 94" x 400'	18.90
0.660	2x8 W11/W4 94" x 400'	19.60
0.690	2x8 W11.5/W4.5 94" x 400'	20.50
0.720	2x8 W12/W5 94" x 400'	21.20



(Area—sq. in. per ft. of width for various spacings)

Wire Size	Number	Nominal Diameter Inches	Nominal Weight Lbs/Lin/ Ft	Center to Center Spacing							
				2"	3"	4"	6"	8"	10"	12"	
W45	D45	0.757	1.530	2.70	1.80	1.35	0.90	0.675	0.540	0.45	
W31	D31	0.628	1.054	1.86	1.24	.93	.62	.465	.372	.31	
W30	D30	0.618	1.020	1.80	1.20	.90	.60	.45	.36	.30	
W28	D28	0.597	.952	1.68	1.12	.84	.56	.42	.336	.28	
W26	D26	0.575	.884	1.56	1.04	.78	.52	.39	.312	.26	
W24	D24	0.553	.816	1.44	.96	.72	.48	.36	.288	.24	
W22	D22	0.529	.748	1.32	.88	.66	.44	.33	.264	.22	
W20	D20	0.505	.680	1.20	.80	.60	.40	.30	.24	.20	
W18	D18	0.479	.612	1.08	.72	.54	.36	.27	.216	.18	
W16	D16	0.451	.544	.96	.64	.48	.32	.24	.192	.16	
W15	D14	0.422	.476	.84	.56	.42	.28	.21	.168	.14	
W12	D12	0.391	.408	.72	.48	.36	.24	.18	.144	.12	
W11	D11	0.374	.374	.66	.44	.33	.22	.165	.132	.11	
W10.5		0.366	.357	.63	.42	.315	.21	.157	.126	.105	
W10	D10	0.357	.340	.60	.40	.30	.20	.15	.12	.10	
W9.5		0.348	.323	.57	.38	.285	.19	.142	.114	.095	
W9	D9	0.338	.306	.54	.36	.27	.18	.135	.108	.09	
W8.5		0.329	.289	.51	.34	.255	.17	.127	.102	.085	
w8	D8	0.319	.272	.48	.32	.24	.16	.12	.096	.08	
W7.5		0.309	.255	.45	.30	.225	.15	.112	.09	.075	
W7	D7	0.299	.238	.42	.28	.21	.14	.105	.084	.07	
W6.5		0.288	.221	.39	.26	.195	.13	.097	.078	.065	
W6	D6	0.276	.204	.36	.24	.18	.12	.09	.072	.06	
W5.5		0.265	.187	.33	.22	.165	.11	.082	.066	.055	
W5	D5	0.252	.170	.30	.20	.15	.10	.075	.06	.05	
W4.5		0.239	.153	.27	.18	.135	.09	.067	.054	.045	
W4	D4	0.226	.136	.24	.16	.12	.08	.06	.048	.04	
W3.5		0.211	.119	.21	.14	.105	.07	.052	.042	.035	
W3		0.195	.102	.18	.12	.09	.06	.045	.036	.03	
W2.9		0.192	.099	.174	.116	.087	.058	.043	.035	.029	
W2.5		0.178	.085	.15	.10	.075	.05	.037	.03	.025	
W2		0.160	.068	.12	.08	.06	.04	.03	.024	.02	
W1.4		0.134	.048	.084	.056	.042	.028	.021	.017	.014	

Note: Wire sizes other than those listed above may be produced provided the quantity required is sufficient to justify manufacture.



QUANTITIES, DESCRIPTIONS & APPROXIMATE WEIGHTS OF PRECAST COMPONENTS:

1 Ea. - 24'-0" x 10'-0" B1 End Section (3'-8" Lay Length)	52,835 #/Ea.
1 Ea. - 24'-0" x 10'-0" B2 Interior Section (4'-0" Lay Length)	54,800 #/Ea.
10 Ea. - 24'-0" x 10'-0" B3 Interior Sections (4'-0" Lay Length)	54,800 #/Ea.
1 Ea. - 24'-0" x 10'-0" B4 Interior Section (3'-8" Lay Length)	50,235 #/Ea.
1 Ea. - 24'-0" x 10'-0" B5 End Section (3'-4" Lay Length)	48,270 #/Ea.
2 Ea. - 1'-0" Wide x 10'-0" Long x 13'-3" Tall WMI Wingwalls	23,055 #/Ea.
2 Ea. - 1'-0" Wide x 10'-0" Long x 13'-3" Tall WMI2 Wingwalls	23,055 #/Ea.
2 Ea. - 3'-0" Wide x 3'-0" Tall Precast E1 Wingwall Footings	31,435 #/Ea.
2 Ea. - 3'-0" Wide x 3'-0" Tall Precast E2 Wingwall Footings	31,435 #/Ea.

APPROVED BY: _____
 COMPANY: _____
 DATE: _____

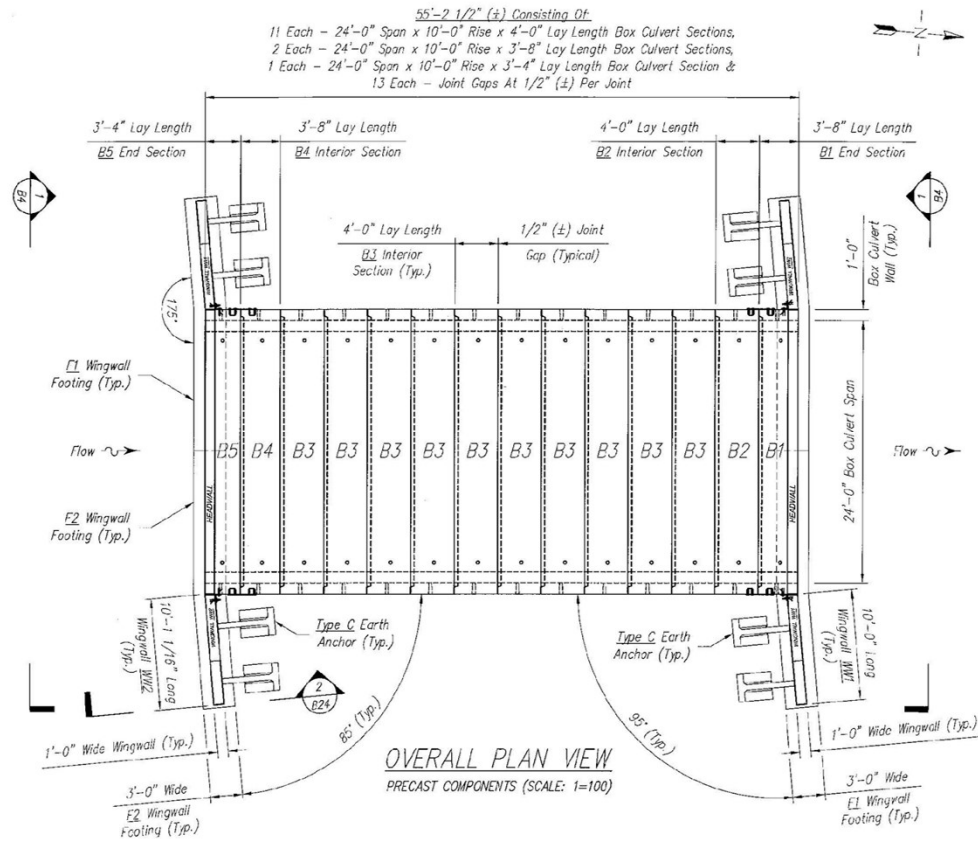

NORTHERN CONCRETE

Revisions:	
No.	Date
1	
2	
3	
4	

Sheet Title: OVERALL PLAN VIEW
 MDOT Design Unit:

24' x 10' BOX CULVERT

Drawing No.	NORTHERN - B3
Drawn By:	JKC
Scale:	1=100
Chk'd By:	TRW
Sheet No.	B3
Date:	03/16/17

401 Kellon Street, Bay City, MI 49706



By: Northern Concrete Pipe, Inc. State Tested: Yes
 Contractor: Baumann Contracting Job: Dempster Road Over Bear Creek Location: Knox County
 Span: 24' Rise: 10' Length: 55' - 2-1/2" Spec: C-1577 HL-93 W/ 1'-3" Cover Design By: _____
 Top: 16" Bottom: 16" Walls: 12" Haunches: 12" x 12" Min Cover: Varies Max Cover: 1'-3" Cover
 # Pcs.: 14 Pieces Inspection By: Department Of Transportation 6500 psi Concrete Yes Air Ent.

	As1	As2	As3	As4	As7	As8	As5	As6	As1 Ext.
Minimum Area (in ² /ft)	1.32	1.56	1.08	.300	.360	.360	X	X	
Concrete Cover (in)	1"- 2"	1-1/4"	1"	1"	2"	2"	X	X	

Outer Cage

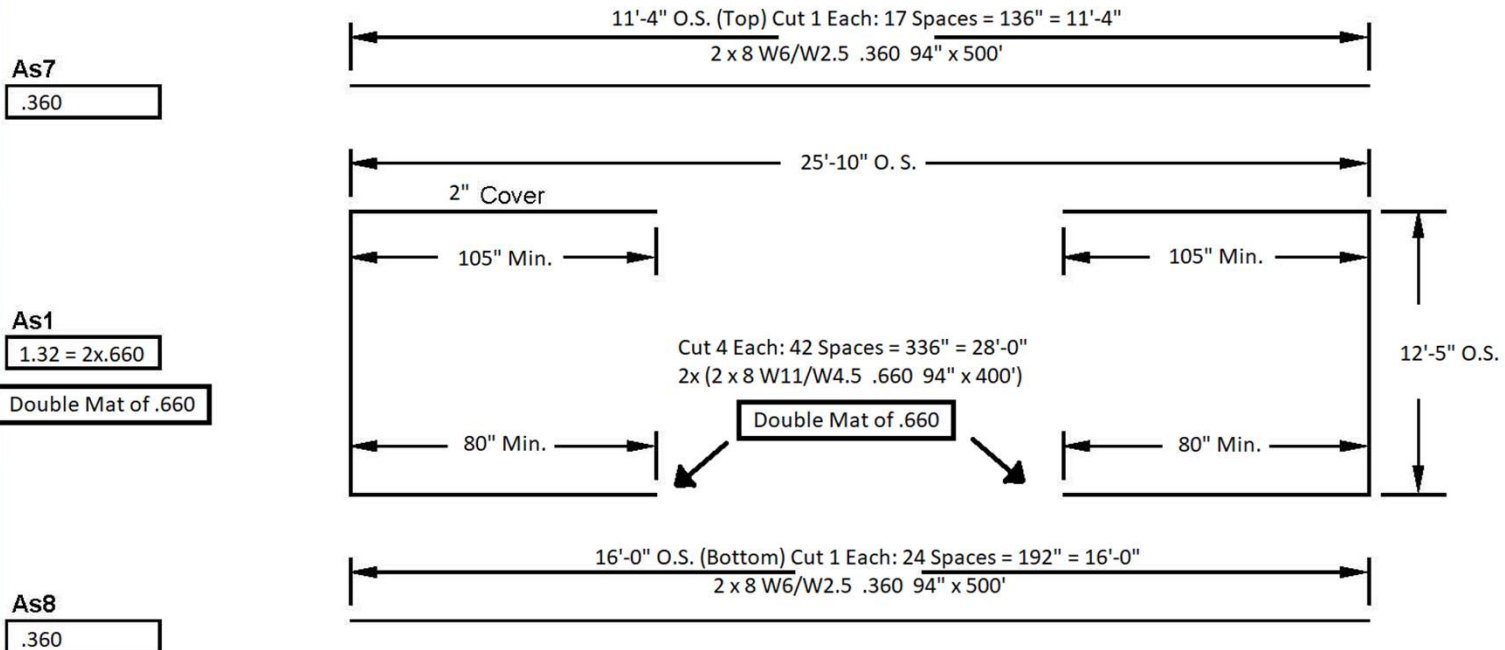



Inner Cage

As2

$1.56 / .312 = 3 \times .540$

Triple Mat of .540
Plus #3 Bar Vertical @ 4" CC

As4

.300

As3

$1.08 / .215 = 2 \times .540$

Double Mat of .540
Plus Mat of .220

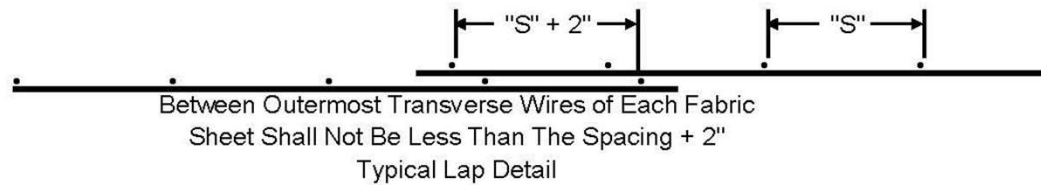
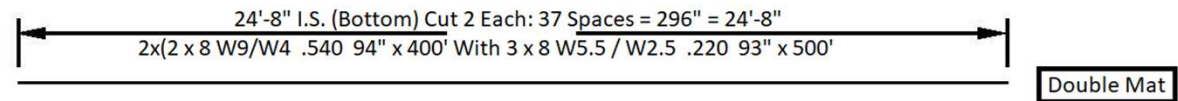
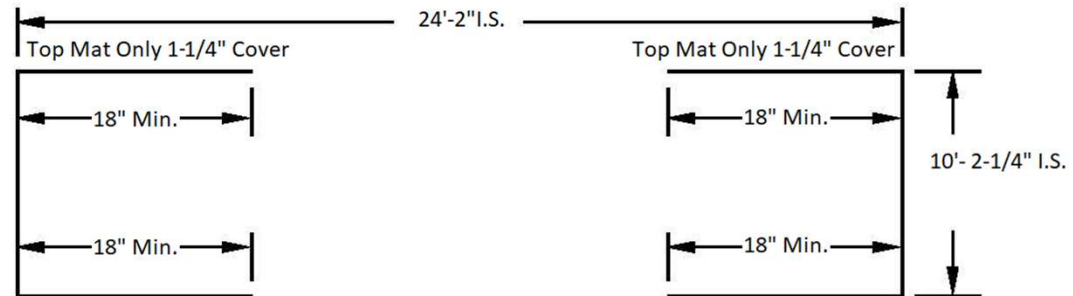
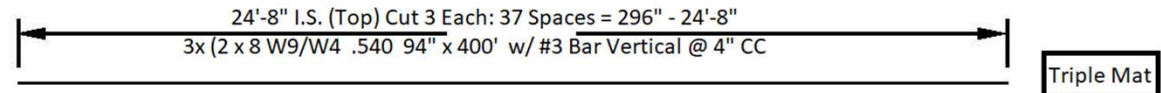



Section 12. **Permissible Variations**; Position or Area of Reinforcement 12.5 or 12.6:

- These Sections only refer to General box culvert cage reinforcement. There are no specifics like there is in PIPE specs.

NOTE: ASTM C1677 which is the specification for concrete box using **RUBBER GASKETS** for joint sealing does state in Section 6; Design of Joints: 6.1.3: The joints of the box shall be of such a design that **they will withstand the forces caused by the compression of the gasket** when joined, without cracking or fracturing when tested.....

This Specification does NOT specifically address the placement or area of the reinforcing like our PIPE specs do. So, this is left up to the design engineers in your Company and the proof testing that your Company does to verify such design.

Figure 1; Typical Box Sections

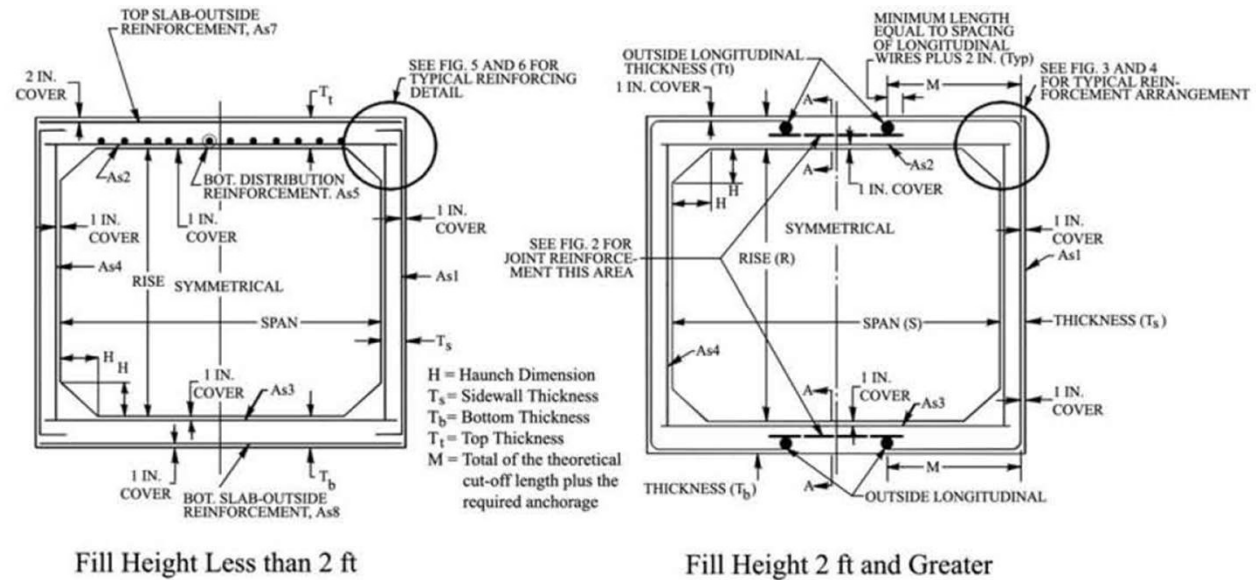



Section 12; Permissible Variations: Those Not Directly Cage Related.

- Section 12.1: **Internal Dimensions**: The internal dimension shall not vary more than 1% or 2" from the design dimensions. (**whichever is less**) (for > 4' dimen.)
- The **Haunch dimensions** shall not vary more than ¼" from the design dimensions.
- Section 12.2: **Slab and Wall Thickness**: The slab and wall thickness shall not be less than that shown in the design by more than 5% or 3/16", whichever is **GREATER**.
- Section 12.3: **Length of opposite surfaces**: Variations in laying lengths of two opposite surfaces of the box section shall not be more than 1/8" per foot of internal span with maximum of 5/8" through 7' span and a maximum of ¾" for all spans greater than 7'.
- Section 12.4: **Length of Section**: The under run length of a section shall not be more than 1/8" per foot of length with a maximum of ½" in any box section.
- **All of these MUST be considered for proper cage positioning!**



PERMISSIBLE VARIATIONS: Position of Reinforcement Section 12.5:

- Remember to consider the Permissible Variations could affect the PRODUCT SHAPE.
- Our cage permissible variations and location requirements are greatly affected by the box culvert product manufacturing process and can put us out of spec if all these details are not monitored by **ALL** Plant staff. **Not just your wire crew staff needs to know and be concerned about these restrictions.**
- Note: All the checks on these slides are required to be checked and recorded by QCast.



PERMISSIBLE VARIATIONS: Position of Reinforcement Section 12.5:

- Position of Reinforcement: The maximum variation in the position of the reinforcement for a **5" or less slab and wall thickness shall be $\pm 3/8$ " and.....**
- for **greater than 5" slab and wall thickness shall be $\pm 1/2$ ".**
- **In no case, however, shall the cover over the reinforcement be less than $5/8$ "**, as measured to the internal surface or the external surface....
- except of the top slab for boxes with under 2' of (earth) cover shall not be less than $1 5/8$ ".
- The preceding minimum cover limitation does not apply at the **mating surfaces** of the joint.



ASTM Permissible Variations C-1577 Section 12.1

Internal Dimensions

Span Or Rise (ft)	Vary +/- (%)	Vary +/- (Inch)	Min Span/Rise (ft)	Max Span/Rise (ft)
4	-	0.50	3.96	4.04
5	1	0.60	4.95	5.05
6	1	0.72	5.94	6.06
7	1	0.84	6.93	7.07
8	1	0.96	7.92	8.08
9	1	1.08	8.91	9.09
10	1	1.20	9.90	10.10
11	1	1.32	10.89	11.11
12	1	1.44	11.88	12.12
13	1	1.56	12.87	13.13
14	1	1.68	13.86	14.14
15	1	1.80	14.85	15.15
16	1	1.92	15.84	16.16
17	1	*2.00	16.83	17.17
18	1	*2.00	17.83	18.17
19	1	*2.00	18.83	19.17
20	1	*2.00	19.83	20.17

* Dimensions Greater Than 4' Shall Not Vary By More Than 1% or 2" From The Design Dimensions, Whichever Is Less.

* Dimensions Less Than Or Equal to 4' Shall Not Vary By More Than 1/2".

* Measurements Are Taken At The Midpoint Of The Span/Rise & 12" From Each End Of The Section.

* Haunch Dimensions Shall Not Vary By More than 1/4" From The Design Dimensions.



Figure 12.1 – C-1577 Permissible Variations – Internal Dimensions

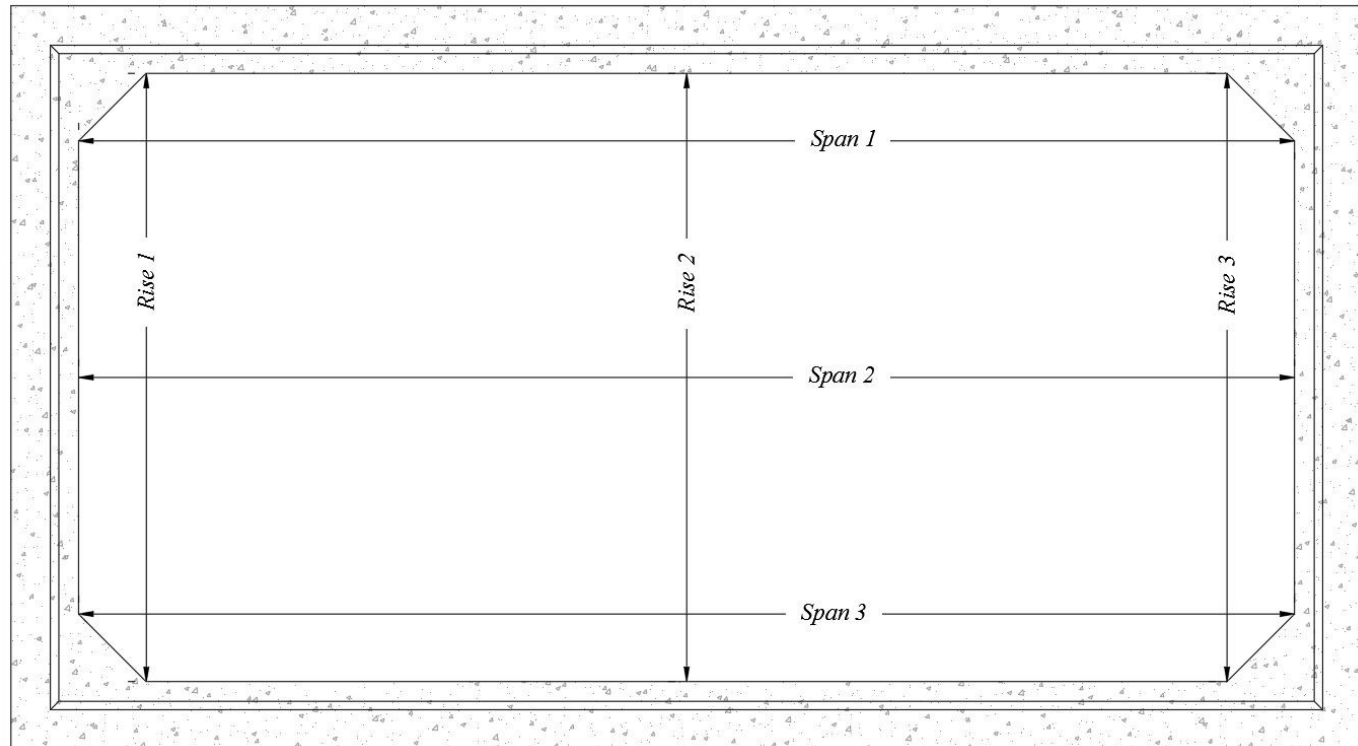



ASTM Permissible Variations C-1577 Section 12.2			
Slab & Wall Thickness			
Slab/Wall Thickness (Inch)	Max Vary (%)	Max Vary (Inch)	Min Thickness (Inch)
4	5	0.20	3.80
5	5	0.25	4.75
6	5	0.30	5.70
7	5	0.35	6.65
8	5	0.40	7.60
9	5	0.45	8.55
10	5	0.50	9.50
11	5	0.55	10.45
12	5	0.60	11.40
13	5	0.65	12.35
14	5	0.70	13.30
15	5	0.75	14.25
16	5	0.80	15.20
17	5	0.85	16.15
18	5	0.90	17.10

* Slab/Wall Thickness Shall Not Be Less Than That Shown In The Design By More Than 5% or 3/16", whichever is greater.
 * A Thickness More Than That Required In The Design Shall Not Be Cause For Rejection.



Figure 12.2 – C-1577 Permissible Variations – Slab & Wall Thickness

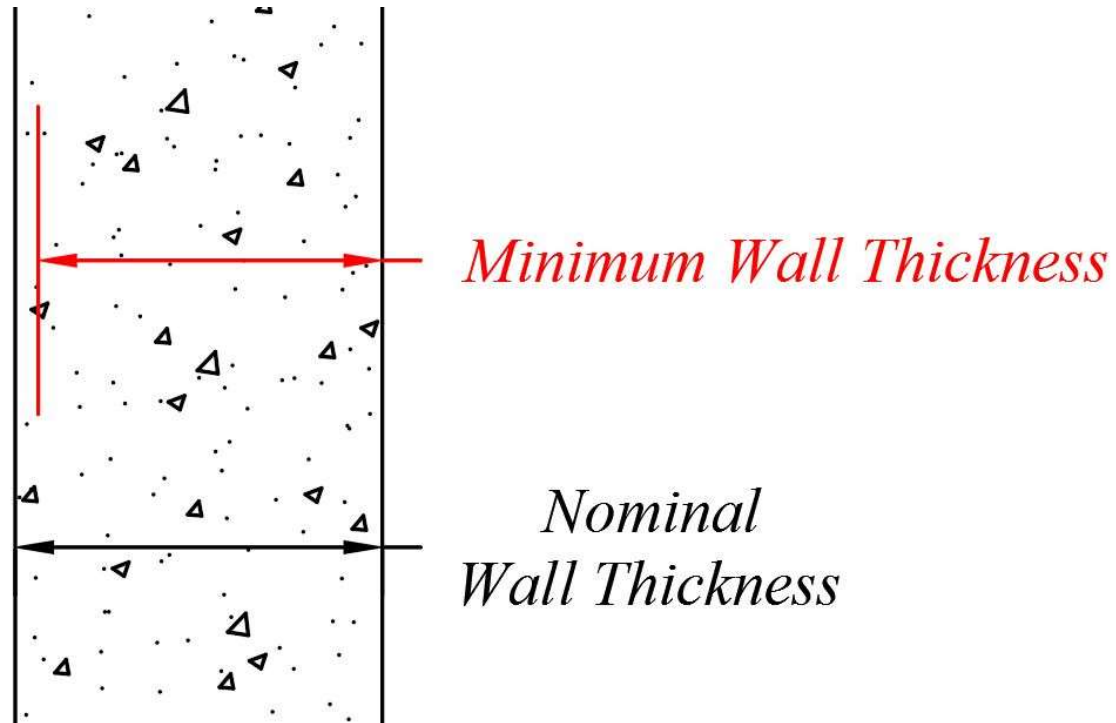



ASTM Permissible Variations C-1577 Section 12.3	
Length Of Opposite Surfaces	
Span	Max Vary Lay Length (Inch)
4	*1/2"
5	*5/8"
6	*5/8"
7	*5/8"
8	**3/4"
9	**3/4"
10	**3/4"
11	**3/4"
12	**3/4"
13	**3/4"
14	**3/4"
15	**3/4"
16	**3/4"
17	**3/4"
18	**3/4"
19	**3/4"
20	**3/4"

*Variations In Lay Lengths of Two Opposite Surfaces Shall Not Be More 1/8" /ft. of Internal Span (Max 5/8" Up To & Including 7' Span)

**Variations In Lay Lengths of Two Opposite Surfaces For Greater Than 7' of Span is Maximum of 3/4"

***Except Where Beveled Ends For Laying Curves Are Specified



Figure 12.3 – C-1577 Permissible Variations – Length of Opposite Surfaces

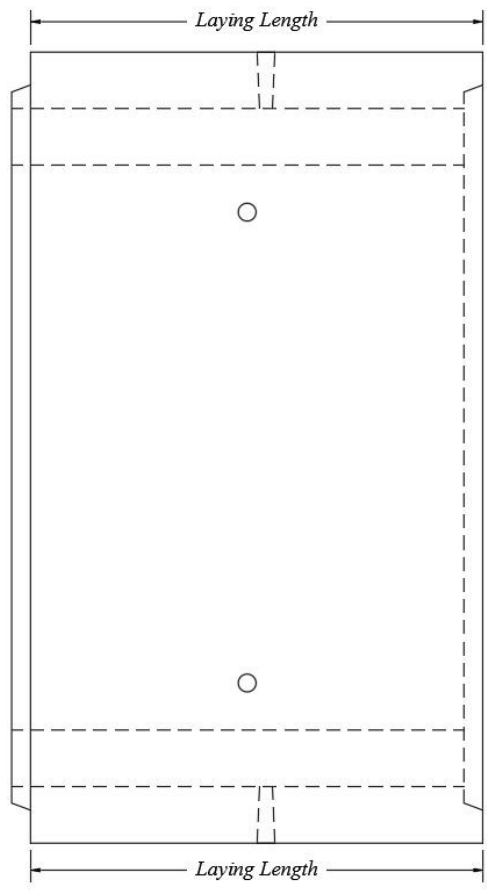



ASTM Permissible Variations C-1577 Section 12.5

Position Of Reinforcement

Wall Thickness	Max Vary +/- (Inch)
4	3/8"
5	3/8"
6	1/2"
7	1/2"
8	1/2"
9	1/2"
10	1/2"
11	1/2"
12	1/2"
13	1/2"
14	1/2"
15	1/2"
16	1/2"
17	1/2"
18	1/2"

* Maximum Variation In Position Of Reinforcement In 5" Or Less Slab/Wall Thickness Shall By +/- 3/8"

* Maximum Variation In Position Of Reinforcement In Greater Than 5" Slab/Wall Thickness Shall By +/- 1/2"

*In No Case Shall The Cover Be Less Than 5/8" As Measured From The Internal or External Surface EXCEPT THE COVER OVER THE REINFORCEMENT FOR THE EXTERNAL SURFACE OF THE TOP SLAB FOR BOXES WITH UNDER 2FT. OF COVER SHALL NOT BE LESS THAN 1-5/8"



Figure 12.5 – C-1577 Permissible Variations – Position of Reinforcement

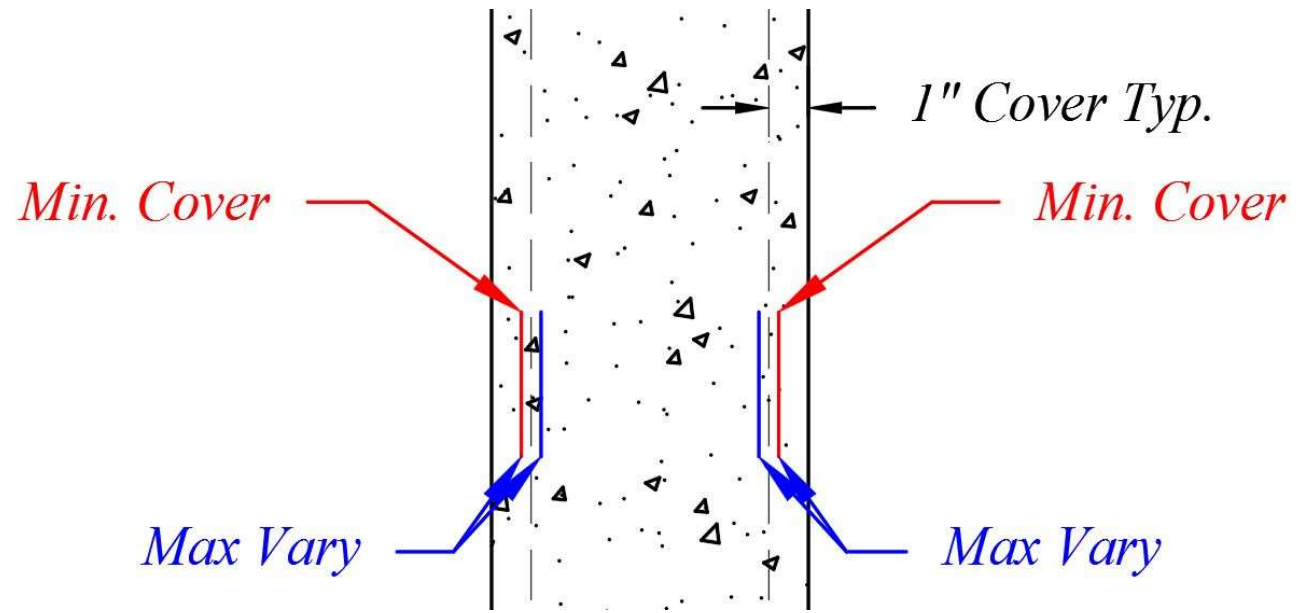



Section 12.6: P.V.; Area of Reinforcement:

- The areas of steel reinforcement shall be the design steel areas as shown in Tables 1 and 2. (OR; Box Car or E.T. Culvert)
- Steel areas **greater** than those required shall NOT be cause for rejection.
- The **permissible variation in diameter of any wire** in finished reinforcement shall conform to the tolerances prescribed for the wire before fabrication by Specification A1064 or A1064M. (You must know what tolerances are allowed in the diameter for drawn wire!)
- If steel bars (Grade 60) are used in lieu of welded-wire reinforcement, the steel areas presented in Tables 1 and 2 shall be **INCREASED** to account for the difference in yield strength, steel spacing, concrete cover and crack control between the welded-wire reinforcement and steel bars. (**Engineering decisions!.....how much?**)



Section 12.7; P.V.; Haunch Dimensions:

- The vertical and horizontal dimensions shall be equal to the side wall thickness.
- If haunches with other dimensions are used, a **SPECIAL REINFORCEMENT DESIGN** for the ACTUAL dimensions shall be completed.
- In lieu of performing a SPECIAL DESIGN, for the specific case where the actual haunch dimensions are larger than the standard dimensions AND vertical AND horizontal haunch dimensions are equal, the As1 steel area shall be increased **1% for EVERY 5% increase in the haunch dimension** over that specified in Table 1 or Table 2 AND As2 and As3 **shall be REDUCED** by an equal percentage.
- You can't just trust this to somebody else! Everyone in your crew needs to know what these parameters are so you have an adequate system of checks and balances to make certain this ALL, always gets considered and adjusted for.



Plant Practices

- Box cages are more challenging to understand and teach our people to understand and build properly. It typically requires the ability to read a print, then take that information to the cage bending machine and bend the cage as designed. I have seen many attempts that do this wrong.
- Just identifying the correct mat to be bent for either the inside or the outside cage is most important; **having left over mats at the end of a project is a very bad thing.** You have to identify what the drawing requires and then find the proper mat for that position on the box cage.
- Then you have to find the center of the mat while knowing how to measure to find that point.
- Figure that out and then you have to understand your particular machine to know where to make the first bend, based on the center point of the mat.
- There can be varying cover requirements on box cages and you have to understand that, before you make your first bend.
- Also, before you bend, you have to know how your plant production process requires the layout of the laps to be....are inside and outside cages the same.....RARELY!
- Over/under bending corners will affect the cover near the bends.
- Spacer placement is different for every box culvert production process.



Plant Practices; Flat Mesh Sheets or Mats:

“If you use ROUND rolls of wire mesh, when it comes out of the wire machine, it has to be flat.”

“Proper flatness depends upon the machine you are using. On most machines it should land on the floor when you count the first 14 full 8” spaces. Lighter wire mesh should hit the floor on 12 to 13 spaces at 8” c-c transverse bars.

“These vary from machine to machine but they are a very consistent and accurate double check that work as a very good starting point to verify your machine operation.”

All types of rolling machines seem to be very close on these counts. We have 6 different machine types this works on.



Plant Practices

- If your wire is coming off your roller like this:



like this coming out uneven.



Improper Cage Machine Set Up



REINFORCEMENT; ASTM points of Importance:

- **“LINE”** of reinforcement definition: circumferential reinforcement comprised of one or more **layers**.
- **“LAYER”** of reinforcement definition: circumferential reinforcement that is one bar or wire in thickness.
- **We have to have them in the right shape and place, regardless of how we get the required area.**



Plant Practices

- Is your wire clean?
- No oil or grease. No dirt. No tags. No paint. etc.....
- RUST: if it has not reduced the diameter of the wire, it will only enhance product strength. It will affect welding on cage machines.
- What does poor wire cleanliness hurt?
- PAINT on wire mats....allowed?



Special Designs

Typically, these special designs can only be submitted by a registered engineer for the Project's owner's approval. **These are not in-plant production decisions!**



Special Designs: Holes/Block Outs





Special Designs: Holes/Block Outs

1206-037

Sta. 32+85

Contractor To Seal Lift Holes & Handling Holes
w/Neoprene Plugs or Approved Equal and Cover
w/Joint Waterproofing or Geotextile and Adhesive.

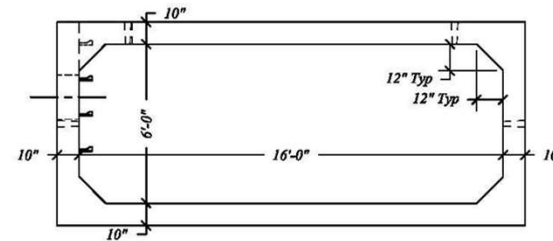
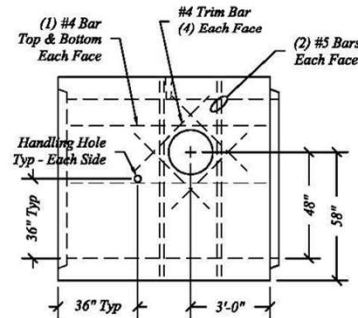
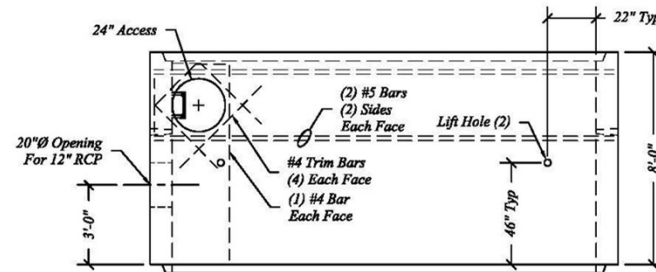

MDOT
STUL 70414 / 113317 A



401 Kelton Street
Bay City, MI 48706
1 800 222 9918

5281 Lansing Road
Charlotte, MI 48813
1 800 874 9701

Proposed - 16' x 6' Precast Concrete Box Culvert

Milbocker & Sons
Allegan, MI

Lincoln Avenue At
Maplewood Drain

Date	Revised	Rev. No.	Drawn By	Scale
07 Jun 12	27 Jun 12	1	BmG	1 : 30

Special Designs: Holes/Block Outs

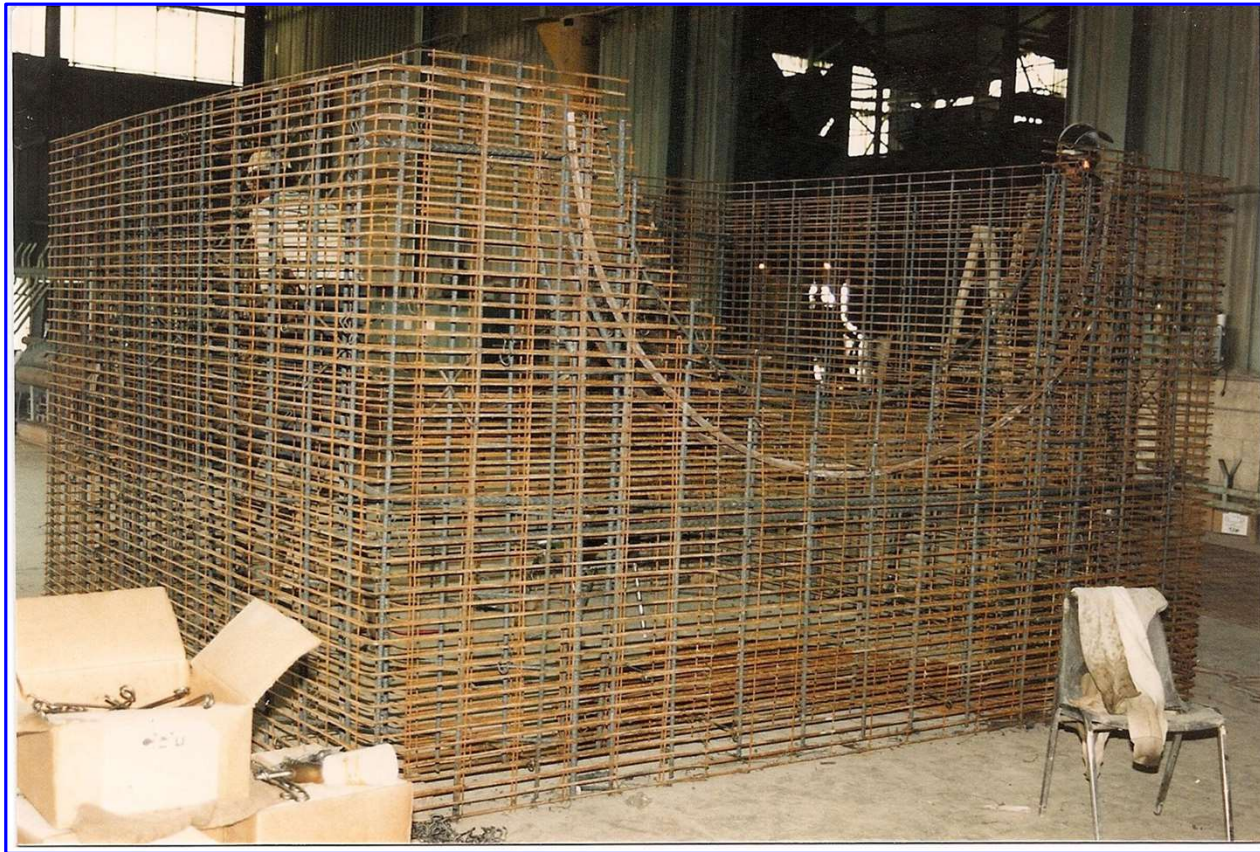



Special Designs: Holes/Block Outs

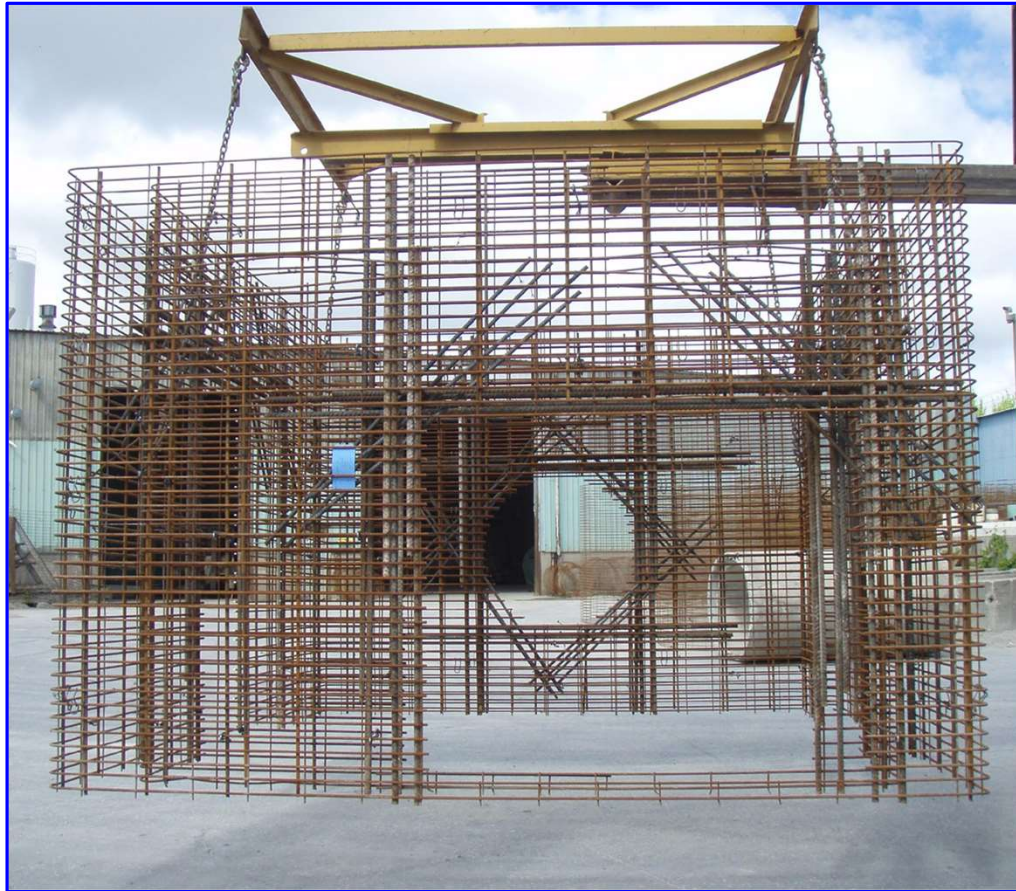



Special Designs: Holes/Block Outs





Special Designs: Shear Reinforcement





Special Designs

Date: 2/21/2012

Shop Drawing

Time: 9:39 AM

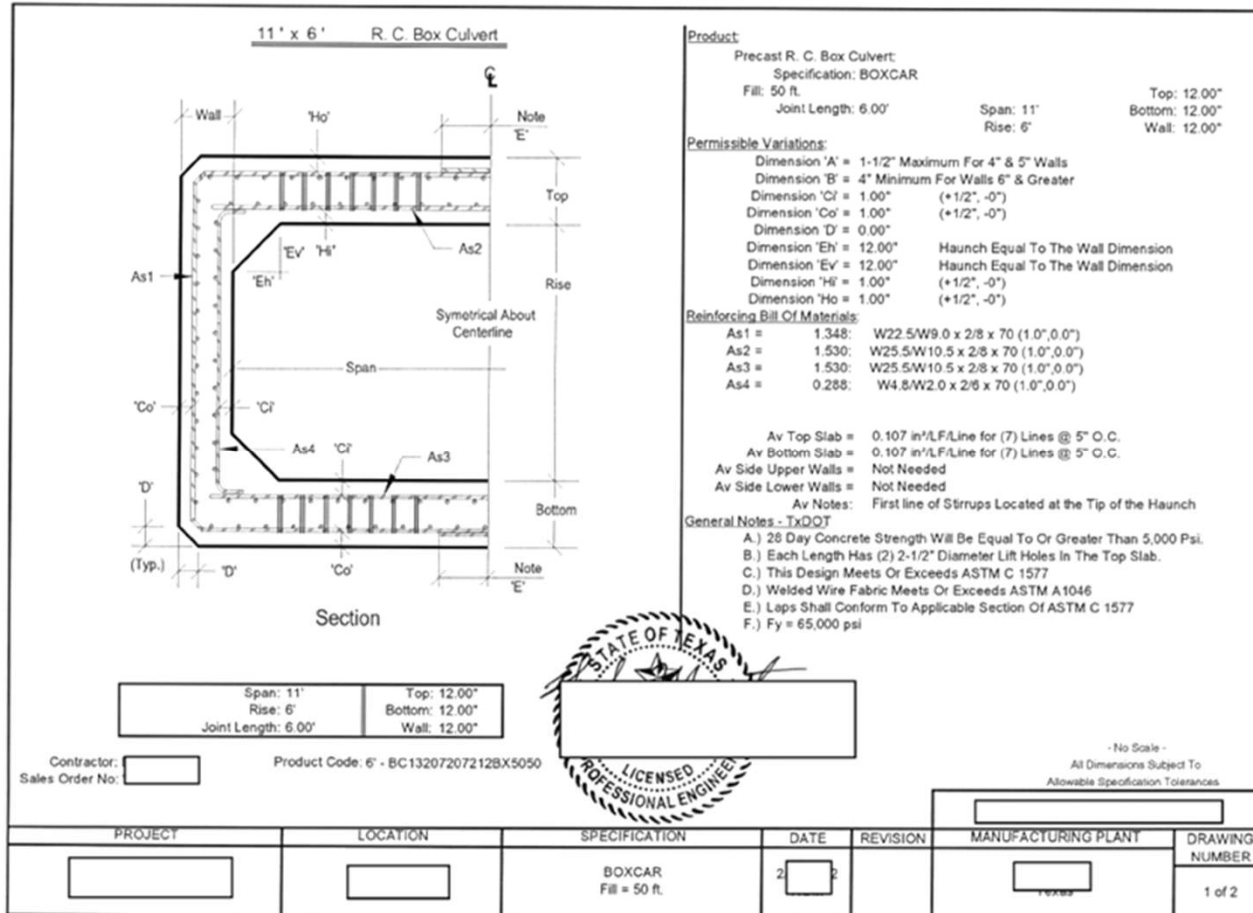

Special Designs





Other Installation Methods

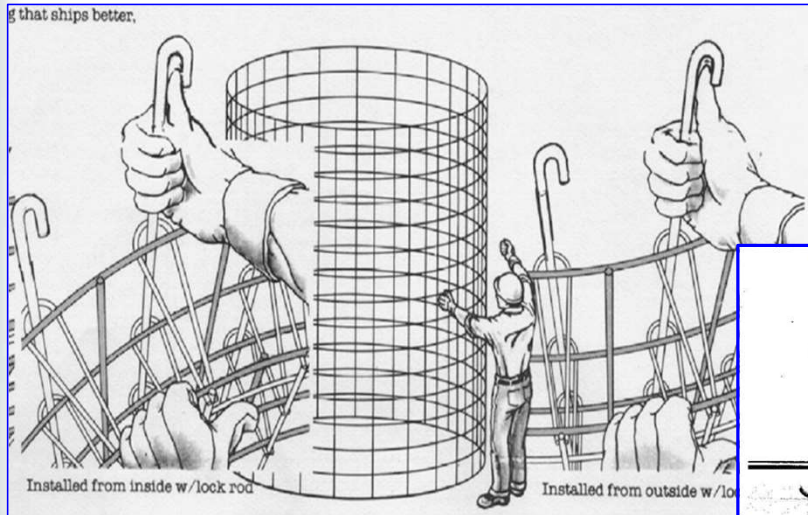

**reinforcement for
large diameter,
deep installation
concrete pipe.**





Individual Spacers

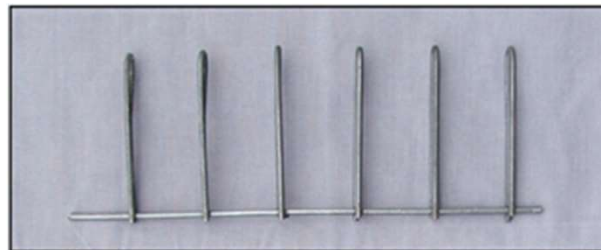
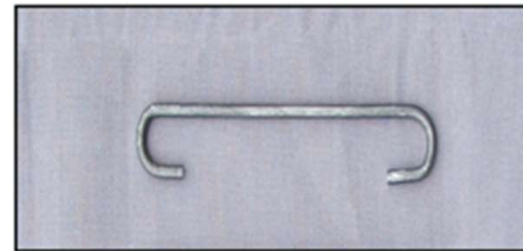
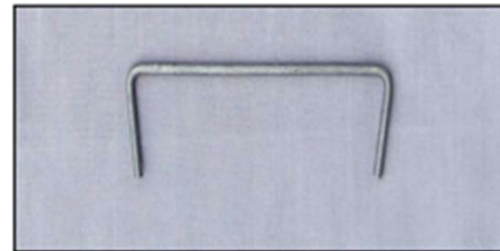
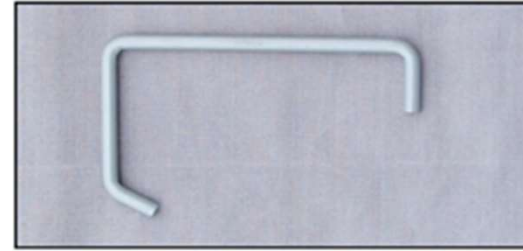
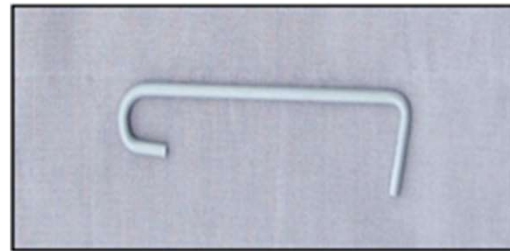



Stirrup Mat Terminology

Engineered Wire Products, Inc.

P.O. Box 313, Upper Sandusky, OH 43351
 Phone: 800-842-8581 Fax: 419-294-1019 / 937-433-5326

DIA:	
WALL:	
CLASS:	
CONCRETE:	
COVER:	
DESIGN SPEC:	
PCS:	LENGTH:

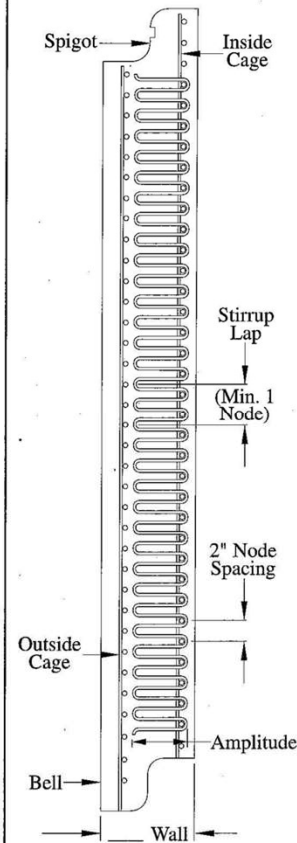

'S'-STIRRUPS REQUIRED	
CROWN	INVERT
AREA REQ'D:	
AMPLITUDE:	
WIRE:	
NODES:	
LINES:	
SPACING:	
ASSEMBLIES:	

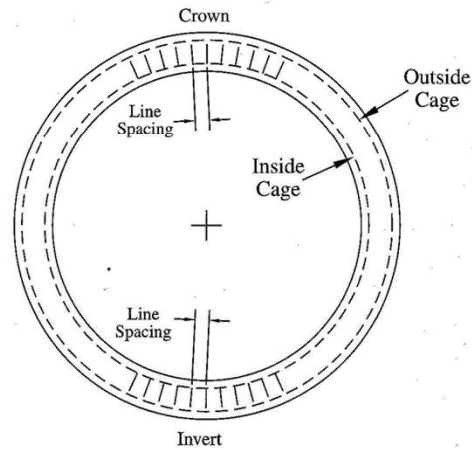

CUSTOMER:	LOCATION:	
CONTACT:	PHONE:	FAX:
PROJECT:		
DATE:	REP:	



Typical Box Shop Drawing

Stirrup mats installed at the tips of haunches. Install the mat loops thru the inside cage toward the outer wall and pin with Lock Rod.

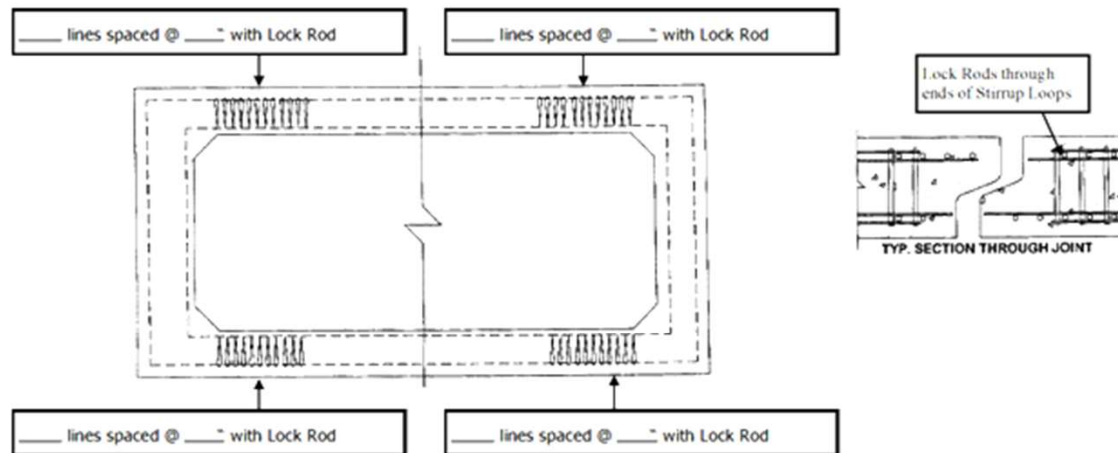

CUSTOMER: _____

BOX DIMENSIONS: _____

STIRRUP AREA: _____ IN SQ/FT OF LINE

TOTAL LINEAR FT: _____ LAY LENGTH: _____

APPROVED BY: _____

DATE: _____

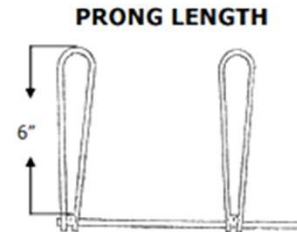

Standard “S”- Stirrups

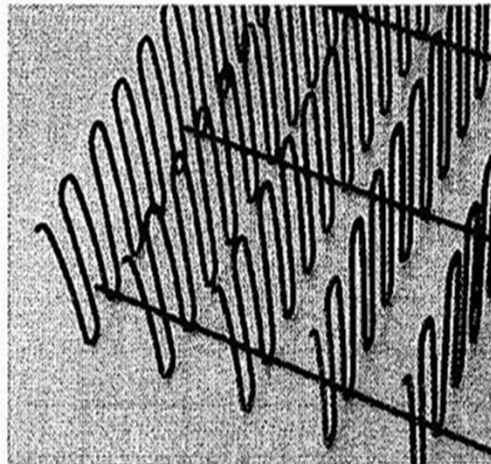

'S'-stirrup assembly

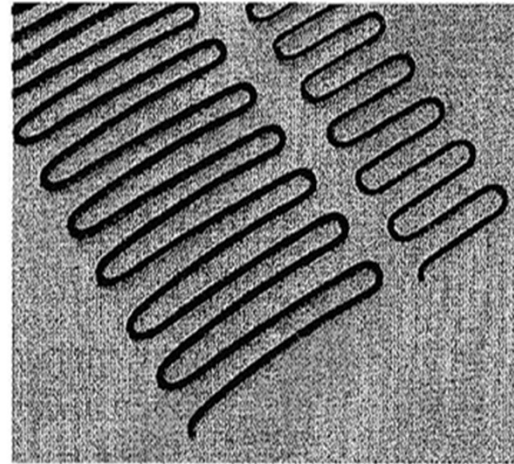

'S'-stirrups



Standard Stirrup Packaging





Ordering Wire or Welded Wire Fabric

- Anyone need some help or that would like to talk about ORDERING these reinforcing materials?
- Everyone know the necessary information needed for placing an order for these materials?



Wire Waste Reduction



- Class suggestions for how do you use roll ends in an efficient cost savings way?
- Manhole bottom wires or base section wires?
- Distribution mats for box culverts?
- As bar chairs or spacers for flat work type cages?
- Your ideas????



Q Cast Inspection Charts

- The next 5 slides are **Q Cast Reinforcing Inspection** Charts that are helpful in training your staff what else needs to be recorded in our product inspections to satisfy our customers Quality Assurance demands.



REINFORCING INSPECTION WORKSHEET

Guideline: Document one cage at start of each shift and if any settings are changed.
Minimum required measurements shown.

Date									
Pipe Size									
Pipe Class									
Pipe Wall									
	Meas.	Spec.	Meas.	Spec.	Meas.	Spec.	Meas.	Spec.	
Dia. - 0°									
Dia. - 90°									
Horiz. Wire Spacing									
Horiz. Wire Dia.									
Area Check									
Vert. Wire Spacing									
Vert. Wire Dia.									
Area Check									
Length									
Lap									
*Bell Dia. - 0°									
*Bell Dia. - 90°									
Weld Check									
Spacer Check size & location									

Wire Machine Safety Stops
Initial if OK

	Monday Date _____	Tuesday Date _____	Wednesday Date _____	Thursday Date _____	Friday Date _____	Saturday Date _____
Machine 1						
Machine 2						
Machine 3						

* expands bell cages

Comments and Corrective Action:



REINFORCING INSPECTION WORKSHEET

Guideline: Document one cage at start of each shift and if any settings are changed.
Minimum required measurements shown.

Date									
Pipe Size									
Pipe Class									
Pipe Wall									
	Meas.	Spec.	Meas.	Spec.	Meas.	Spec.	Meas.	Spec.	
Dia. - 0°									
Dia. - 90°									
Horiz. Wire Spacing									
Horiz. Wire Dia.									
Area Check									
Vert. Wire Spacing									
Vert. Wire Dia.									
Area Check									
Length									
Lap									
*Bell Dia. - 0°									
*Bell Dia. - 90°									
Weld Check									
Spacer Check size & location									

Visual Inspections

(Include Reinforcing Placement, Handling Holes/Lifting Devices, Tie-pin Holes, Release Agent Application, Form Cleanliness and Condition, Step Holes/ Plugs.)

Initial if Acceptable				
-----------------------	--	--	--	--

* expands bell cages

Comments and Corrective Action:



Box Culvert Reinforcement Inspection Cont.

Place a check mark in the box under **OK** if requirement is met, or a check mark under **HOLD** if requirement is not met.

End Cover			
Item	OK	Hold	Remarks
Circumferential ₁			
Longitudinal ₂			
Multiple Layers			
Item	OK	Hold	Remarks
Separation ₃			
Weld Placement ₄			
Laps			
Item	OK	Hold	Remarks
Min. Lap ₅			
Weld Placement ₆			
Critical Welding Zones			
Item	OK	Hold	Remarks
As2 Mid 1/3 ₇			
As3 Mid 1/3 ₇			
Distribution Steel			
Item	OK	Hold	Remarks
Weld Placement ₈			
Spacers			
Item	OK	Hold	Remarks
Location ₉			
Size ₁₀			

1. Not less than 1/2 inch or greater than 2 inches from the end of the box section
2. Not greater than 2 inches from the end of the box section
3. Not greater than one longitudinal thickness plus 1/4 inch
4. If not tied, welds shall be made to selected circumferential wire not less than 18 inches apart
5. One longitudinal spacing plus 2 inches or 10 inches, whichever is greater
6. If not tied, welds shall be made to selected circumferential wire not less than 18 inches apart (at corners of As1, As7 & As8, see Fig. 9 of C1577 & C1433 "Critical Zones of High Stress Where Welding is Restricted")
7. No welding permitted due to high stress (see Fig. 9 in C1577 & C1433 "Critical Zones of High Stress Where Welding is Restricted")
8. Welds shall only be made to longitudinal wires, and only within 18" from the end of the box section
9. Verify that spacers are in the correct location on the cage per manufacturer's drawings
10. Verify against manufacturer's drawings that the correct size of spacer(s) are used



Three-sided Structure - Flat Deck Reinforcement Inspection Cont.

Place a check mark in the box under OK if requirement is met, or a check mark under HOLD if requirement is not met.

End Cover			
Item	OK	Hold	Remarks
Circumferential ₁			
Longitudinal ₂			
Multiple Layers			
Item	OK	Hold	Remarks
Separation ₃			
Weld Placement ₄			
Laps			
Item	OK	Hold	Remarks
Min. Lap ₅			
Weld Placement ₆			
Critical Welding Zones			
Item	OK	Hold	Remarks
Top Span Mid 1/3 ₇			
1/4 Top Span from Corners ₈			
Legs ₉			
Distribution Steel			
Item	OK	Hold	Remarks
Weld Placement ₁₀			
Spacers			
Item	OK	Hold	Remarks
Location ₁₁			
Size ₁₂			

1. Not less than 1/2 inch or greater than 2 inches from the ends of each section
2. Not more than 2" from the ends of the three-sided section
3. Not greater than one longitudinal thickness plus 1/4 inch
4. If not tied, welds shall be made to selected circumferential wire not less than 18" apart
5. One longitudinal spacing plus 2 inches or 10 inches, whichever is greater
6. If not tied, welds shall be made to selected circumferential wire not less than 18" a part along longitudinal axis of three-sided section
7. No welding to inside circumferential cage permitted due to high stress
8. No welding to outside circumferential cage permitted due to high stress
9. No welding to outside circumferential cage permitted due to high stress
10. Welds shall only be made to longitudinal wires or bars, and only within 18" from the end of the three-sided section
11. Verify that spacers are in the correct location on the cage per manufacturer's drawings
12. Verify against manufacturer's drawings that the correct size of spacer(s) are used



Three-sided Structure - Arch Deck Reinforcement Inspection Cont.

Place a check mark in the box under **OK** if requirement is met, or a check mark under **HOLD** if requirement is not met.

End Cover			
Item	OK	Hold	Remarks
Circumferential ₁			
Longitudinal ₂			
Multiple Layers			
Item	OK	Hold	Remarks
Separation ₃			
Weld Placement ₄			
Laps			
Item	OK	Hold	Remarks
Min. Lap ₅			
Weld Placement ₆			
Critical Welding Zones			
Item	OK	Hold	Remarks
Top Span Mid 1/3 ₇			
1/4 Top Span from Corners ₈			
Legs ₉			
Distribution Steel			
Item	OK	Hold	Remarks
Weld Placement ₁₀			
Spacers			
Item	OK	Hold	Remarks
Location ₁₁			
Size ₁₂			

1. Not less than 1/2 inch or greater than 2 inches from the ends of each section
2. Not more than 2" from the ends of the three-sided section
3. Not greater than one longitudinal thickness plus 1/4 inch
4. If not tied, welds shall be made to selected circumferential wire not less than 18" apart
5. One longitudinal spacing plus 2 inches or 10 inches, whichever is greater
6. If not tied, welds shall be made to selected circumferential wire not less than 18" apart along longitudinal axis of three-sided section
7. No welding to inside circumferential cage permitted due to high stress
8. No welding to outside circumferential cage permitted due to high stress
9. No welding to outside circumferential cage permitted due to high stress
10. Welds shall only be made to longitudinal wires or bars, and only within 18" from the end of the three-sided section
11. Verify that spacers are in the correct location on the cage per manufacturer's drawings
12. Verify against manufacturer's drawings that the correct size of spacer(s) are used



Reinforcement Combinations

- Where is our industry headed? Research & Technology is not waiting for us!

Thin wall 120" RCP with a 6.5" wall instead of a 10" "A" wall.

- ONE CAGE in the middle of the wall or a single Elliptical cage.
- All with ADDITIONAL FIBER reinforcing.





Questions?

Thank you for your attention today!

Please take this information back to your Plant(s) and make sure all your staff members get a good understanding of just how important this is to all of our futures.



- Additional Information and Appendix:



Q Cast Inspection Charts

- The next 3 slides are **Q Cast Reinforcing Inspection** Charts that are helpful in training your staff what else needs to be recorded in our product inspections to satisfy our customers Quality Assurance demands.



Q Cast Inspection Forms

Section VI

PLANT CERTIFICATION

Box Culvert Reinforcement Inspection - Single Cell

Identification	
Fabrication Date	
Span	
Rise	
Design, Table #	
Earth Cover, Min.	
Earth Cover, Max.	

Date: _____

Inspector: _____

Comments: _____

Circumferential and Longitudinal Reinforcing Areas, in ² /ft.					
Mark	Required	Used	Mesh Style	Length "L"	"M"*
A _s 1					
A _s 2					N/A
A _s 3					N/A
A _s 4					N/A
A _s 5					N/A
A _s 6					N/A
A _s 7					N/A
A _s 8					N/A
Inserts			N/A	N/A	N/A
Spacers			N/A	N/A	N/A
*Lap			N/A	N/A	N/A

*Where reinforcing cages are overlapped, lap splices for WWR must equal 1 longitudinal wire spacing plus 2 in. and greater than or equal to 10 in.
 **M only applies as a design option for boxes with a fill height of 2 ft. and greater.

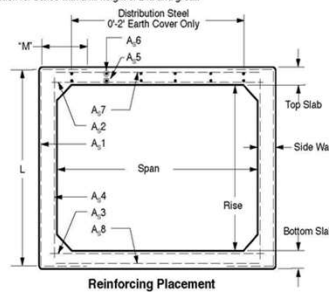



Q Cast Inspection Forms

Box Culvert Reinforcement Inspection Cont.

Place a check mark in the box under **OK** if requirement is met, or a check mark under **HOLD** if requirement is not met.

End Cover			
Item	OK	Hold	Remarks
Circumferential ₁			
Longitudinal ₂			
Multiple Layers			
Item	OK	Hold	Remarks
Separation ₃			
Weld Placement ₄			
Laps			
Item	OK	Hold	Remarks
Min. Lap ₅			
Weld Placement ₆			
Critical Welding Zones			
Item	OK	Hold	Remarks
As2 Mid 1/3 ₇			
As3 Mid 1/3 ₈			
Distribution Steel			
Item	OK	Hold	Remarks
Weld Placement ₉			
Spacers			
Item	OK	Hold	Remarks
Location ₁₀			
Size ₁₀			

1. Not less than 1/2 inch or greater than 2 inches from the end of the box section
2. Not greater than 2 inches from the end of the box section
3. Not greater than one longitudinal thickness plus 1/4 inch
4. If not tied, welds shall be made to selected circumferential wire not less than 18 inches apart
5. One longitudinal spacing plus 2 inches or 10 inches, whichever is greater
6. If not tied, welds shall be made to selected circumferential wire not less than 18 inches apart (at corners of As1, As7 & As8, see Fig. 9 of C1577 & C1433 "Critical Zones of High Stress Where Welding is Restricted")
7. No welding permitted due to high stress (see Fig. 9 in C1577 & C1433 "Critical Zones of High Stress Where Welding is Restricted")
8. Welds shall only be made to longitudinal wires, and only within 18" from the end of the box section
9. Verify that spacers are in the correct location on the cage per manufacturer's drawings
10. Verify against manufacturer's drawings that the correct size of spacer(s) are used



Q Cast Inspection Forms

Section VI PLANT CERTIFICATION

Box Culvert Reinforcement Inspection - Double Cell

Identification
Fabrication Date
Span
Rise
Design, Table #
Earth Cover, Min.
Earth Cover, Max.

Date: _____

Inspector: _____

Comments: _____

Circumferential and Longitudinal Reinforcing Areas, in ² /ft.					
Mark	Required	Used	Mesh Style	Length "L"	"M"
A _s 1					
A _s 2					N/A
A _s 3					N/A
A _s 4					N/A
A _s 5					N/A
A _s 6					N/A
A _s 7					N/A
A _s 8					N/A
A _s 9					N/A
A _s 10					N/A
Inserts			N/A	N/A	N/A
Spacers			N/A	N/A	N/A
*Lap			N/A	N/A	N/A

*Where reinforcing cages are overlapped, lap splices for WWR must equal 1 longitudinal wire spacing plus 2 in. and greater than or equal to 10 in.

**M only applies as a design option for boxes with a fill height of 2 ft. and great.

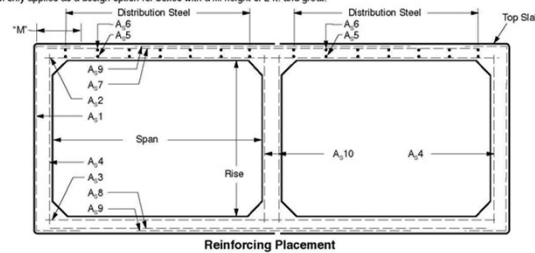



Q Cast Inspection Forms

PLANT CERTIFICATION

Section VI

Box Culvert Reinforcement Inspection Cont.

Place a check mark in the box under **OK** if requirement is met, or a check mark under **HOLD** if requirement is not met.

End Cover			
Item	OK	Hold	Remarks
Circumferential ₁			
Longitudinal ₂			
Multiple Layers			
Item	OK	Hold	Remarks
Separation ₃			
Weld Placement ₄			
Laps			
Item	OK	Hold	Remarks
Min. Lap ₅			
Weld Placement ₆			
Critical Welding Zones			
Item	OK	Hold	Remarks
As2 Mid 1/3 ₇			
As3 Mid 1/3 ₈			
Distribution Steel			
Item	OK	Hold	Remarks
Weld Placement ₉			
Spacers			
Item	OK	Hold	Remarks
Location ₁₀			
Size ₁₀			

1. Not less than 1/2 inch or greater than 2 inches from the end of the box section
2. Not greater than 2 inches from the end of the box section
3. Not greater than one longitudinal thickness plus 1/4 inch
4. If not tied, welds shall be made to selected circumferential wire not less than 18 inches apart
5. One longitudinal spacing plus 2 inches or 10 inches, whichever is greater
6. If not tied, welds shall be made to selected circumferential wire not less than 18 inches apart (at corners of As1, As7 & As8, see Fig. 9 of C1577 & C1433 "Critical Zones of High Stress Where Welding is Restricted")
7. No welding permitted due to high stress (see Fig. 9 in C1577 & C1433 "Critical Zones of High Stress Where Welding is Restricted")
8. Welds shall only be made to longitudinal wires, and only within 18" from the end of the box section
9. Verify that spacers are in the correct location on the cage per manufacturer's drawings
10. Verify against manufacturer's drawings that the correct size of spacer(s) are used



Box Culvert Reinforcement Inspection Cont.

Place a check mark in the box under **OK** if requirement is met, or a check mark under **HOLD** if requirement is not met.

End Cover			
Item	OK	Hold	Remarks
Circumferential ₁			
Longitudinal ₂			
Multiple Layers			
Item	OK	Hold	Remarks
Separation ₃			
Weld Placement ₄			
Laps			
Item	OK	Hold	Remarks
Min. Lap ₅			
Weld Placement ₆			
Critical Welding Zones			
Item	OK	Hold	Remarks
As2 Mid 1/3 ₇			
As3 Mid 1/3 ₇			
Distribution Steel			
Item	OK	Hold	Remarks
Weld Placement ₈			
Spacers			
Item	OK	Hold	Remarks
Location ₉			
Size ₁₀			

1. Not less than 1/2 inch or greater than 2 inches from the end of the box section
2. Not greater than 2 inches from the end of the box section
3. Not greater than one longitudinal thickness plus 1/4 inch
4. If not tied, welds shall be made to selected circumferential wire not less than 18 inches apart
5. One longitudinal spacing plus 2 inches or 10 inches, whichever is greater
6. If not tied, welds shall be made to selected circumferential wire not less than 18 inches apart (at corners of As1, As7 & As8, see Fig. 9 of C1577 & C1433 "Critical Zones of High Stress Where Welding is Restricted")
7. No welding permitted due to high stress (see Fig. 9 in C1577 & C1433 "Critical Zones of High Stress Where Welding is Restricted")
8. Welds shall only be made to longitudinal wires, and only within 18" from the end of the box section
9. Verify that spacers are in the correct location on the cage per manufacturer's drawings
10. Verify against manufacturer's drawings that the correct size of spacer(s) are used



Q Cast Documentation

- Note:
- Q Cast does not go into enough inspection of welds in my opinion but I do have to admit that I only say this to keep your Q C people on their toes monitoring this, because I personally don't have a suggestion for a better way....yet.



This document is not an ASTM standard and is intended only to provide the user of an ASTM standard an indication of what changes have been made to the previous version. Because it may not be technically possible to adequately depict all changes accurately, ASTM recommends that users consult prior editions as appropriate. In all cases only the current version of the standard as published by ASTM is to be considered the official document.



Designation: **G1577—19b C1577 – 20**

Standard Specification for Precast Reinforced Concrete Monolithic Box Sections for Culverts, Storm Drains, and Sewers Designed According to AASHTO LRFD¹

This standard is issued under the fixed designation C1577; the number immediately following the designation indicates the year of original adoption or, in the case of revision, the year of last revision. A number in parentheses indicates the year of last approval. A superscripted epsilon (ϵ) indicates an editorial change since the last revision or approval.

1. Scope*

1.1 This specification covers single-cell precast reinforced concrete box sections cast monolithically and intended to be used for the construction of culverts and for the conveyance of storm water, industrial wastes and sewage.

Note 1.—This specification is primarily a manufacturing and purchasing specification. However, standard designs per the AASHTO LRFD Bridge Design Specifications are included and the criteria used to develop these designs are given in *Appendix XI*. The successful performance of this product depends upon the proper selection of the box section, bedding, backfill, and care that the installation conforms to the construction specifications. The purchaser of the precast reinforced concrete box sections specified herein is cautioned that proper correlation of the loading conditions and the field requirements with the box section specified, and provision for inspection at the construction site, are required.

1.2 The values stated in inch-pound units are to be regarded as standard. No other units of measurement are included in this standard.

1.3 *This international standard was developed in accordance with internationally recognized principles on standardization established in the Decision on Principles for the Development of International Standards, Guides and Recommendations issued by the World Trade Organization Technical Barriers to Trade (TBT) Committee.*

2. Referenced Documents

2.1 ASTM Standards:²

- A1064/A1064M Specification for Carbon-Steel Wire and Welded Wire Reinforcement, Plain and Deformed, for Concrete
- A615/A615M Specification for Deformed and Plain Carbon-Steel Bars for Concrete Reinforcement
- A706/A706M Specification for Deformed and Plain Low-Alloy Steel Bars for Concrete Reinforcement
- C33/C33M Specification for Concrete Aggregates
- C150/C150M Specification for Portland Cement
- C260/C260M Specification for Air-Entraining Admixtures for Concrete
- C309 Specification for Liquid Membrane-Forming Compounds for Curing Concrete
- C494/C494M Specification for Chemical Admixtures for Concrete
- C497 Test Methods for Concrete Pipe, Concrete Box Sections, Manhole Sections, or Tile
- C595/C595M Specification for Blended Hydraulic Cements
- C618 Specification for Coal Fly Ash and Raw or Calcined Natural Pozzolan for Use in Concrete

¹ This specification is under the jurisdiction of ASTM Committee C13 on Concrete Pipe and is the direct responsibility of Subcommittee C13.07 on Acceptance Specifications and Precast Concrete Box Sections.

Current edition approved 1998-11-01; 1999-02-15, 2002; Published September 2002; November 2020. Originally approved in 2005. Last previous edition approved in 2019 as G1577—19b C1577 – 20b. DOI: 10.1520/C1577-20.

² For referenced ASTM standards, visit the ASTM website, www.astm.org, or contact ASTM Customer Service at service@astm.org. For Annual Book of ASTM Standards volume information, refer to the standard's Document Summary page on the ASTM website.

*A Summary of Changes section appears at the end of this standard.



List of ACPA Associate Members who are our Preferred Suppliers for the Materials used in this Program:

CAM - Concrete Accessory Manufacturing – Joan Suda, joan.suda@afinitas.com

Davis Wire Corp. – William Cantrell, wcantrell@daviswire.com

Eastern States Steel Corp. - Dave Swenson, dswenson@spacers.com

Liberty Engineered Wire Products - Jeff Babcock, jeff.babcock@libertysteel.us

Helix Steel - Wes Dees, wes.dees@helixsteel.com

Insteel Wire Products, Inc. - Dean Hatley, dhatley@insteel.com

King Steel – Mike Shall, mshall@kingsteelcorp.com

O'Brien Wire – Ken West, kwest@obrienwire.com

Superior Wire & Technical Services – Bill Dickerman, knparts.1@gmail.com

Special Designs





Other Installation Methods

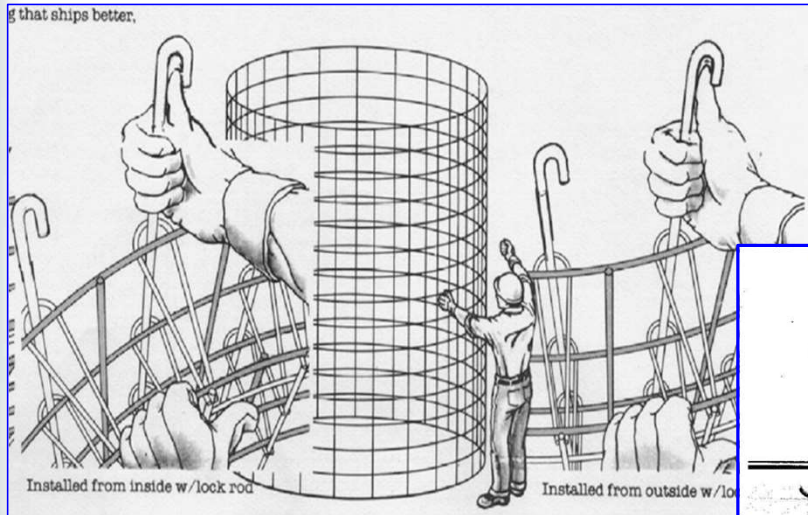

**reinforcement for
large diameter,
deep installation
concrete pipe.**

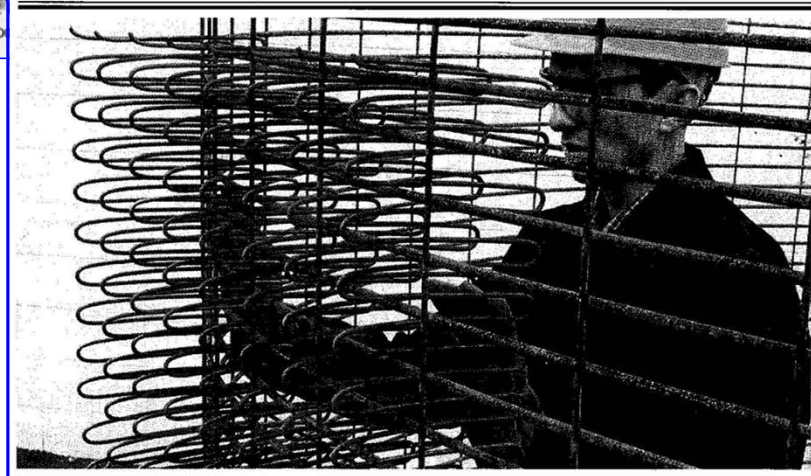



Individual Spacers

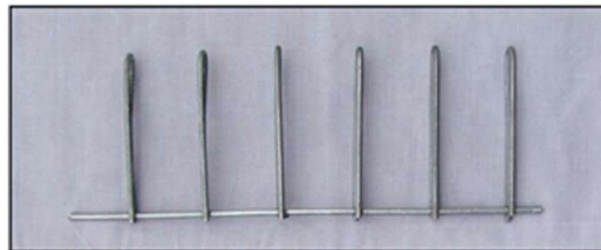
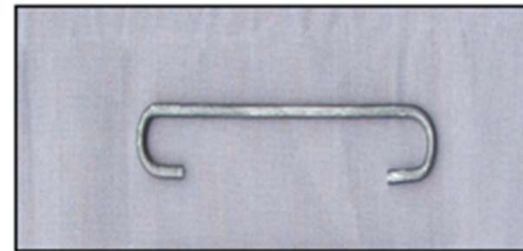
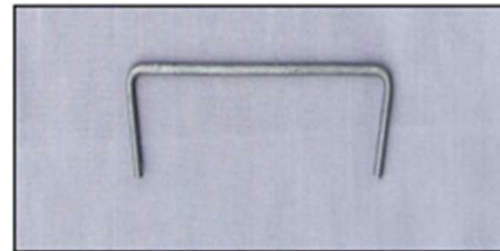
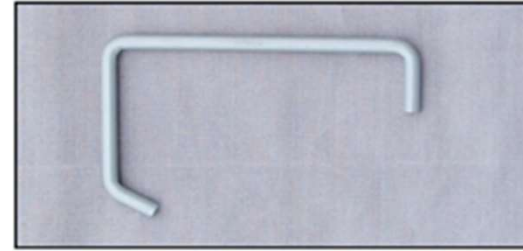
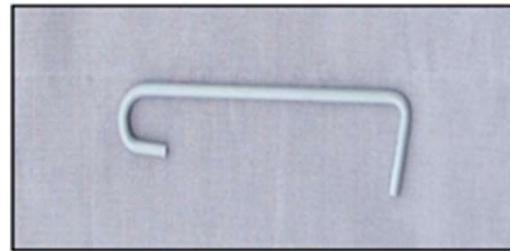



Additional WELDING Info (if Time Permits at the End of the Class)

- The following few slides are also on the ACPA website.
- These are CRITICAL safety points that every manufacturer has to consider before they allow any of this to be done in their facility!



Welding Rebar

- In general, welding rebar is not a good practice.
- Many specifications are starting to require procedure prequalification (PQR) to confirm the compatibility of the combined materials.
- Be careful about welding too close to a bend. Typically it is recommended to terminate rebar welds a minimum of 2" or 2 bar diameters from the start of the bend.
- Rebar is difficult to weld and the heat process of the welding process can degrade the load carrying capacity of the steel. This can be overcome by experienced and certified welders and selection of a suitable weldable grade of rebar.
- The pre-stressed concrete PCI Manual and ACI have standards for some of this that we don't have time for today.
- "W" (weldable) stamped into the deformations and "S" denoting compliance with multi-grade bars for [ASTM A706/A615](#).



WARNINGS: Welding Attachments to Reinforcing Cages; Actual Manufacturer's Recommendations and Safety Factor Concerns Examples:

PRODUCT SAFETY “...guarantees its products, as shipped from the factory and when the above factors are taken into account. These products are intended for use by qualified and experienced workmen. **Even slight misuse, misapplication or lack of supervision and inspection can contribute to serious accidents.”**



Shop or Job Site Arc Welding

“**DO NOT WELD TO ANY CASTING**, unless in the opinion of a qualified engineer, such welding is in a non-critical area. Welding to castings causes embrittlement at the load point and greatly reduces the load carrying capacity. Tack welding of wire products can have the same effect. Since.....is not able to control field conditions or field workmanship,.....**DOES NOT GUARANTEE** any of its products **altered** in any way (including welding or bending) after leaving the factory.”



Safety Notes and Product Application

“Do not weld rebar to any portion of an anchor. **Do not weld to lifting hardware units.** Welding may cause embrittlement and result in failure. It is necessary to have good working knowledge of materials, heat treatment and welding procedures before welding is to be considered. Since Is not able to control field conditions or field workmanship, **DOES NOT GUARANTEE** any product **altered** after leaving the factory.”



Stirrup and prefabricated shear steel wire installation in both pipe and box culverts should only be done where allowed by [ASTM](#) and on non-critical cage positions such as on to the transverse or longitudinal wires.







GALVANIZING OF ANCHORS

“NOTE: Due to the Anchors heat treatment, hydrogen embrittlement may occur during the galvanizing process”

This is just another reason not to weld on anchors.



Shop or Field Welding

“Welding of precast accessories can be hazardous. Knowledge of materials, heat treatment and welding procedures is necessary for proper welding.

DO NOT WELD ANY CASTING unless approved by a licensed metallurgical engineer. Welding to iron castings causes carbides and extreme brittleness near the weld point **and destroys most of the castings load value**. Since we cannot control either the workmanship or conditions under which this work is done, Cannot be responsible for any product **altered** in the field by welding, bending, or any other modification.”



Typical Variables That Effect The Capacity of Cast-In Anchors and Lifting Units.

- Damage or Modification
“Do not weld or modify lifting units or anchors. The user should establish an inspection system to check components prior to use. Damaged, worn, or deformed products should be discarded.”
- Failure to observe any safety recommendations can result in a service failure of a lifting system possibly leading to injury or death.”



Questions?

Thank you for your attention today!

Please take this information back to your Plant(s) and make sure all your staff members get a good understanding of just how important this is to all of our futures.



Appendix #1

Date: 2/21/2012

Shop Drawing

Time: 9:39 AM

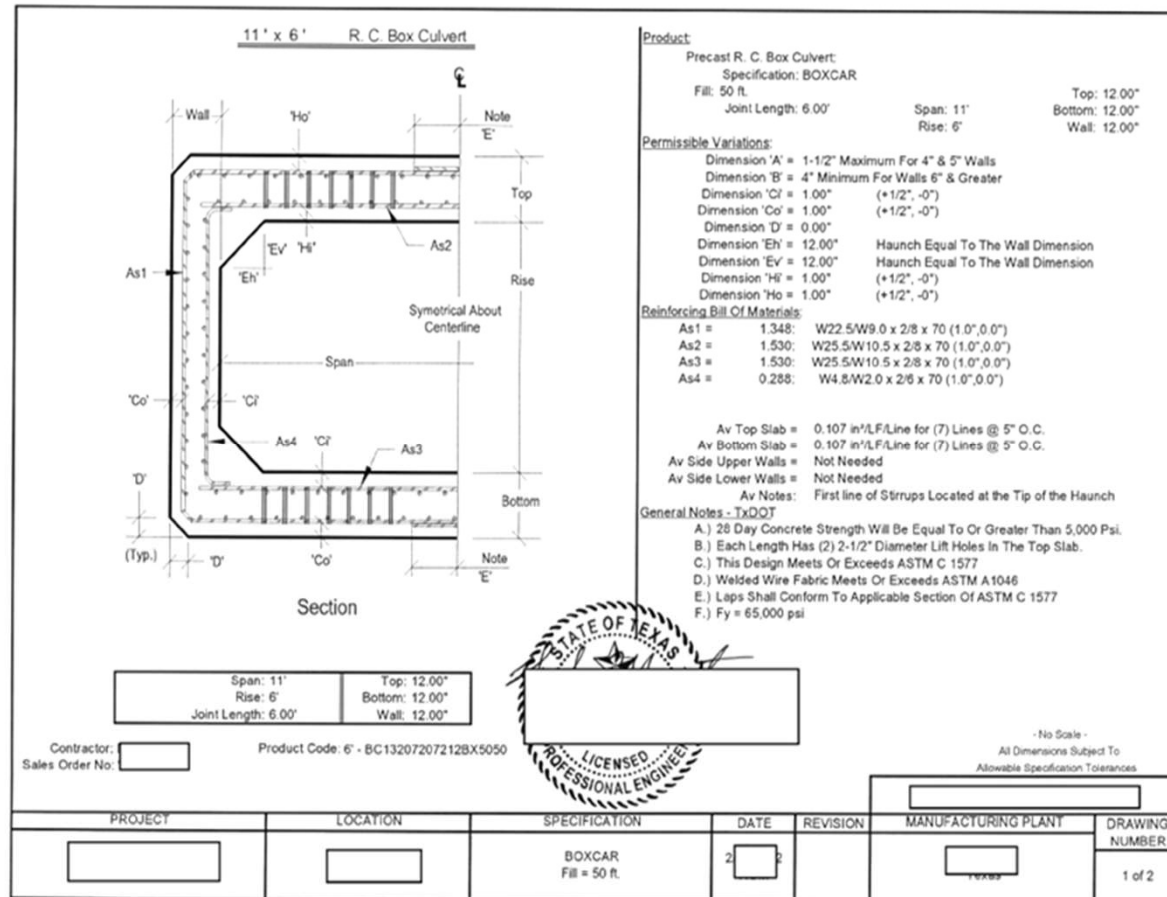



Appendix #1: One ACPA Member's Box Culvert Production Program:

Box Cage Fabrication

Ensure the correct steel mats for inner and outer cage fabrication

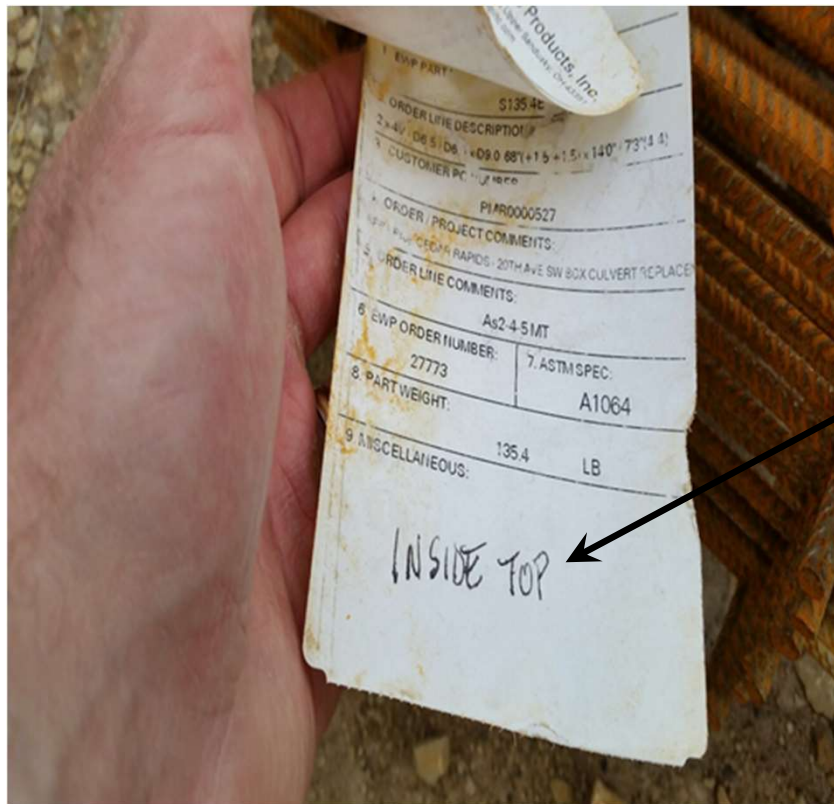

-Check steel identification tag on mats from supplier

-Match it up to the box steel fabrication drawing for the job

-Mark the steel tag what the mat will be used for, (Inside Top Cage in this Example)

-In this case, this mat will be used for the inside cage and it is the stack of steel for the top mats



Appendix #1: One ACPA Member's Box Culvert Production Program:

Box Cage Fabrication

Ensure the correct steel mats for inner and outer cage fabrication

Make an error proof process:

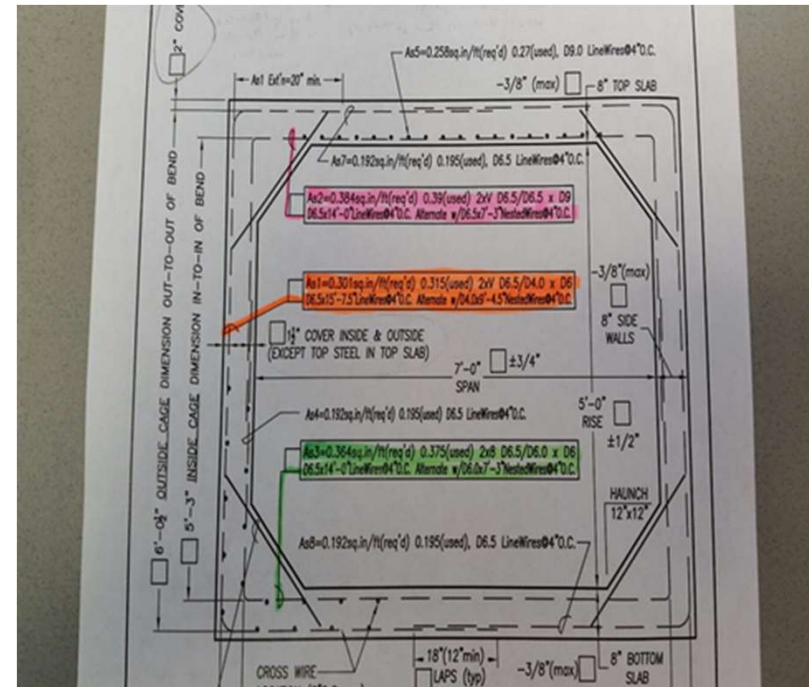

Color code mats and steel drawings to match up steel with drawings. Orange paint and high light used to match the mats with the drawing; Outer cage in this example.



Appendix #1: One ACPA Member's Box Culvert Production Program:

Box Cage Fabrication

Box cage steel practices to follow for each project:

- Measure mesh sheets when starting cage production
 - Check to see if there are differences in total length of the mats
 - Varying mat lengths can effect the bend location and proper over lap when joining the cage halves
- Store box steel in your yards on concrete or proper dunnage to keep the mat steel clean



Appendix #1: One ACPA Member's Box Culvert Production Program:

Box Cage Fabrication

Finding the location to make the bends on the cage mat:

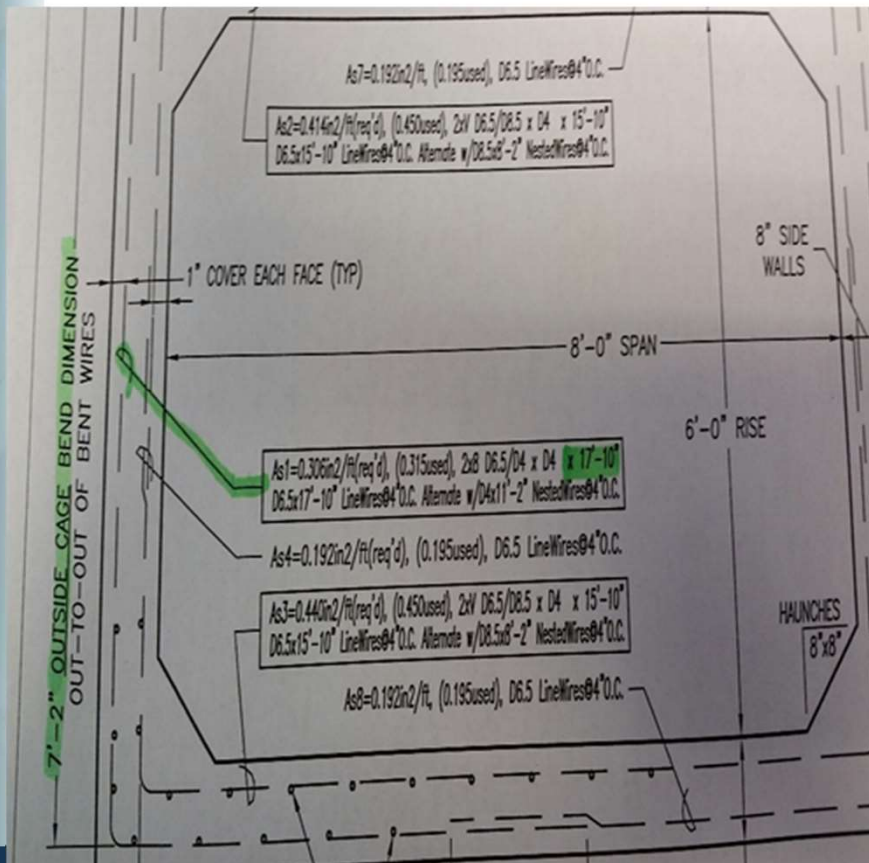

1. Convert total length of mat to inches
 - In example, mat length is 17'-10" = 214"
2. Then take your bend measurement and convert it to inches: 7'-2" = 86"
3. Next take the total mat lengths of 214" and subtract the cage bend measurement of 86" to equal 128"
4. Now divide the 128" by 2 to equal 64". This is the bend length of each cage end.



Appendix #1: One ACPA Member's Box Culvert Production Program:

Box Cage Fabrication

Finding the location to make the bends on the cage mat:



-Measure from tip of the cage mat back 64" and make a mark on the mat to match that distance.

-Make marks at 64" on bars on both sides of the mat

-This will help with properly aligning the mat on the bender table and locating the cage mat for the bender.



Appendix #1: One ACPA Member's Box Culvert Production Program:

Box Cage Fabrication

Properly locate and align the cage mat:

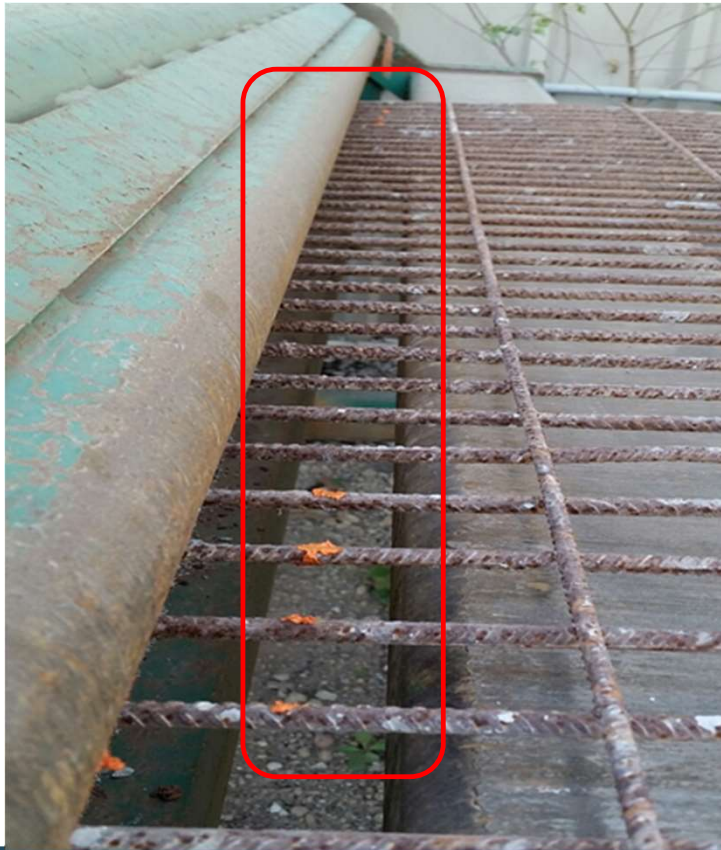

-Align all marks on the cage mat to marks on the machine to properly locate and align the steel mat.

-Ensure mat is aligned squarely under the bender and on the table prior to bending the cage

- Failure to follow this step could result in making a bend in the cage that is not square

-Once the mat is properly located, make the bend in the mat.



Appendix #1: One ACPA Member's Box Culvert Production Program:

Box Cage Fabrication

Make the bend on the cage mat:



- Make the bend in the cage mat
- Bend the mat to a 90 degree angle and perform a visual inspection of the formed corner
- Make adjustments to the cage based on the inspection if needed
- Bend the mat more if not at 90 degrees or pull the mat back while still secured in the bender is the bend is too great (over bent)
- In this example, we needed to bend the cage a little more as we were not quite at 90 degrees to achieve a square corner



Appendix #1: One ACPA Member's Box Culvert Production Program:

Box Cage Fabrication

Measure and check the dimension of the bend:



-Measure the bend (distance from the cage tail to the bend point) to ensure the correct dimension has been obtained

- This needs to be done before making the second bend on the cage mat

-If the first bend is off a bit, adjustments can be made to the location on the cage mat on where to make the second bend

-If the first bend is short of the required distance, length can be added back to the second bend to ensure the cage bend and cage laps will still be good. The opposite adjustment can be made if the first cage bend is too long.



Appendix #1: One ACPA Member's Box Culvert Production Program:

Box Cage Fabrication

Measure and mark location for the second cage bend:



-Next measure the distance for the second bend to be made on the cage mat.

-This drawing called out 7'-2".

-Measure 7'-2" from the first bend and mark the cage mat at the point as shown.

Again, make marks at the desired distance on both sides of the mat to help with alignment on the bender.

-Repeat the same process to make the second bend in the cage mat as was done to make the first bend.



Appendix #1: One ACPA Member's Box Culvert Production Program:

Box Cage Fabrication

Measure the formed cage section to ensure the dimension is correct:



-Since this is an **outside cage**, measure from the outer edge of the steel straight across to the opposite side outer edge of the mat steel

-If this was an **inside cage**, we would hold the bar on the inner edge of the steel and measure straight across to the inner edge of the opposite cage bar

-Measure your cage as it would set on the pallet

-Make your measurement in the corner of the cage as shown. 7'-2" was the dimension to achieve



Appendix #1: One ACPA Member's Box Culvert Production Program:

Box Cage Fabrication

Cage Bending Equipment:

Generally there are two main types of benders used for box steel fabrication:

90 degree steel bender



Radius steel bender





Appendix #1: One ACPA Member's Box Culvert Production Program:

Box Cage Fabrication

Cage Bending Equipment:

- Whether using a 90 degree bender or a radius bender understand how it bends the cage steel
- Develop a standard procedure to follow for all employees who are using the benders to fabricate cages. Procedure should include these main points:
 - How to properly locate and align the steel mats on the bender before bending the mats
 - How to correctly measure and mark the steel to obtain the proper bend locations on the cage mats
- Each bender tends to have some minor differences.
 - If using a radius bender, understand how the bend dimension will change as the steel is formed around the radius forming the bend
 - For most 90 degree benders, locate the bend marks on your steel directly under the bending arm for best results

Understand how the bender works, develop a work procedure and follow it!



Appendix #1: One ACPA Member's Box Culvert Production Program:

Box Cage Fabrication

Tips for Bending Box Steel: Radius Steel Bender



-Mark made on the bending arm for alignment and location of cage mats

-Cage mats are measured and bend point marked and aligned with mark on bender

-Alignment mark on this bender is approx. **1 ½ inches** off the bending point to compensate for the radius on the bending surface as the mat bend is formed

-If this is not taken into account on the radius style benders, cage bends will be off



Appendix #1: One ACPA Member's Box Culvert Production Program:

Box Cage Fabrication

Tip for improving Cage Bend Consistency: Adjustable stops added to bender



- Stops added to the bender to keep the steel from moving/sliding while the cage is being bent.
- Moved up against the cross wires to secure the mat
- Helps keep bend points more consistent and true





Appendix #1: One ACPA Member's Box Culvert Production Program:

Box Cage Fabrication

Tips for Improving Cage Bend Consistency:



-Added piece of slide to the bending arm to keep the steel mats from slipping

-Keeps mat from moving while the cages are being bend

-Help ensure consistent bend location

-Located the slide lag in the middle of the bending arm

- Still allows the bending arm to lock into place when put down over the steel mat



Appendix #1: One ACPA Member's Box Culvert Production Program:

Box Cage Fabrication

Proper cage handling and storage:



This is NOT the proper way to store or move former steel mats!

- Correct cage bend dimensions can change when stored or moved with a forklift in this position
- Stress added to the bends can cause the ends to flare out resulting in:
 - Poor fit for the cages halves
 - Improper concrete coverage in the corners of the box sections
 - Difficult to add box locks or spacers to connect the inside of the outside cages
- The larger the cage section the greater the probability of damage



Appendix #1: One ACPA Member's Box Culvert Production Program:

Box Cage Fabrication

Proper cage handling and storage:



This is the proper way formed cage mats should be stored:

- Formed bends are not stressed in this position and the cage will retain original bend dimensions
- When being moved by a forklift, carry the cage section with the ends facing downward on the forks
- Tip the cage section off the forks to the position shown here
- Carrying the cage section with the ends facing up can cause them to spring out causing fit issues in the jacket and concrete coverage issues



Appendix #1: One ACPA Member's Box Culvert Production Program:

Box Cage Fabrication

Helpful Cage Assembly Tools



Notches are cut out of the pipe and fastened to the cage sections to properly set the cage laps and dimensions.

- Built cage holders specific to the cages for the project

- Holds cages to allow laps to be tied together at the correct location

- Makes cage assembly easier for the employees

- Holders made out of round steel pipe, flat stock steel or conduit



Appendix #1: One ACPA Member's Box Culvert Production Program:

Box Cage Fabrication

Dedicated pallet jig for cage production:



- Angle iron tack welded to the pallet to locate inside and outside cages in the core/jacket assembly

- Used to help set and assemble cage laps

- When setting up jig pallet consider:

- Thickness of steel used for cages

- Required concrete coverage over steel the reinforcing

- Cage locators can be moved in or out to compensate for differing wall thickness, concrete coverage requirements and steel thickness



Appendix #1: One ACPA Member's Box Culvert Production Program:

Box Cage Fabrication

Dedicated pallet jig for cage production:



- Inside cage assembled on the jig pallet
- Cage sections pulled up against stops and are tied together
- Same process followed for the outer cage assembly
- While cage guides can be helpful and make the cage assembly faster, employees still need to verify the cage dimensions with a tape measure before using it for production.



Appendix #1: One ACPA Member's Box Culvert Production Program:

Box Cage Fabrication

Cage box locks/spacers:



- Use the correct number of cage spacers/box locks
- Too few of spacers can leave a cage assembly too loose causing the cage to distort
- Too few of spacers can cause the cage to shift and move inside the jacket causing concrete coverage issues.
- Too many spacers can be costly
- General rule is to place spacers within top and bottom 6" of the cage assembly
- If in doubt, placing a few extra spacers on a cage assembly to ensure proper concrete coverage and cage stability is better than not using enough spacers.



Appendix #1: One ACPA Member's Box Culvert Production Program:

Box Cage Fabrication

Cage box locks/spacers: The Not-So-Good and The Good

Not enough cage spacers/box locks. This cage will shift and move when poured leading to potential quality issues.

Correct number of spacers/box locks. This cage is solid, straight in the jacket, and will experience minimal movement when poured.





Appendix #1: One ACPA Member's Box Culvert Production Program:

Box Cage Fabrication

Cage spacers/box locks:



- **DO NOT** use extra spacers/box locks to compensate for poorly formed cages
- If the spacers/box locks do not fit well when joining the inside and outside cages, something is probably not formed correctly with a cage section
- Measure the cage again.....
- **MAKE SURE** your crew is using the correct size spacers and box locks for the wall thickness of the box being built.
- Work with your spacer/box lock vendor to get the correct cage spacers/box locks for the box culvert job you are working on



Appendix #1: One ACPA Member's Box Culvert Production Program:

Box Cage Fabrication

Cage spacers/box locks and cage construction:



- Tried to use extra spacers to correct a cage that was formed correctly
- Extra rework
- Bad looking box culvert sections
- Subject to rejection due to improper steel reinforcement coverages
- Do not give the customer reasons to question the quality of the box culvert sections you are supplying them.



Appendix #2

Primer For Welded Wire Reinforcement In
Precast Reinforced Concrete Box Culverts

PRIMER FOR WELDED WIRE REINFORCEMENT IN PRECAST REINFORCED CONCRETE BOX CULVERTS

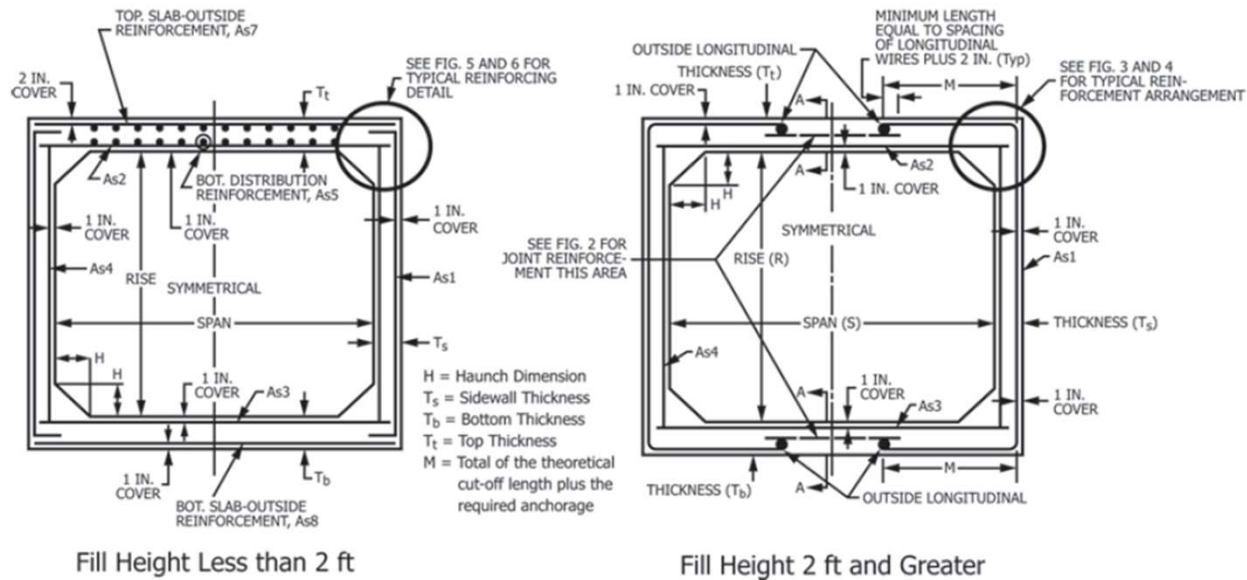



The use of welded wire reinforcement (WWR) is prevalent in the precast industry, with reinforced concrete box culvert structures being a prime example.

WWR is directly referenced as a reinforcement solution in leading structural engineering software, acknowledging the product's broad acceptance throughout the AASHTO LRFD Bridge Design Specification.

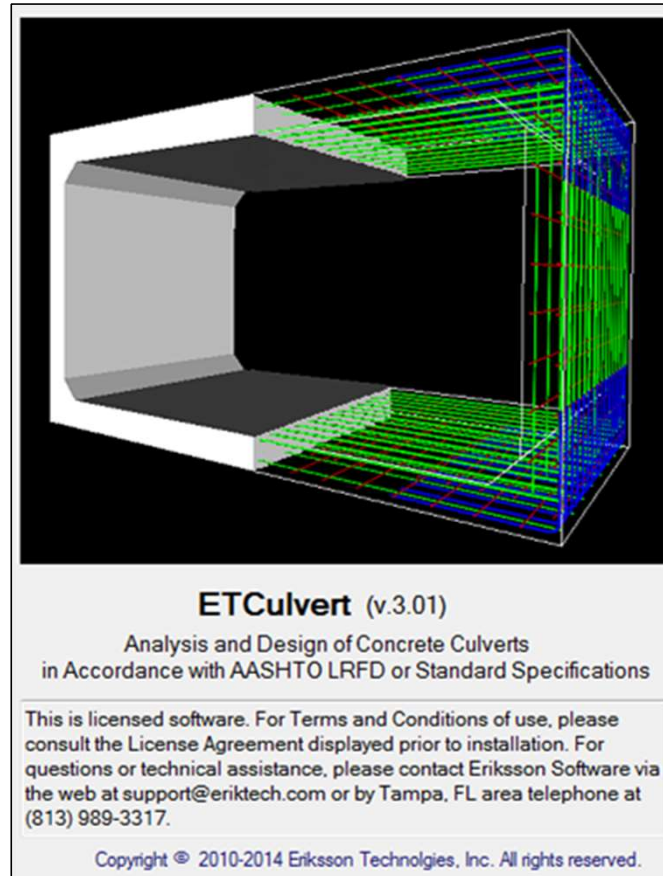



Precast contractors can yield tremendous benefit through the engagement of a WWR manufacturer early on in the project bid process.

The WWR manufacturer in turn leverages engineering and detailing expertise to assist the contractor in establishing preliminary materials pricing information that is both technically accurate with regards to code compliance, and cost efficient to suit contractor directive.

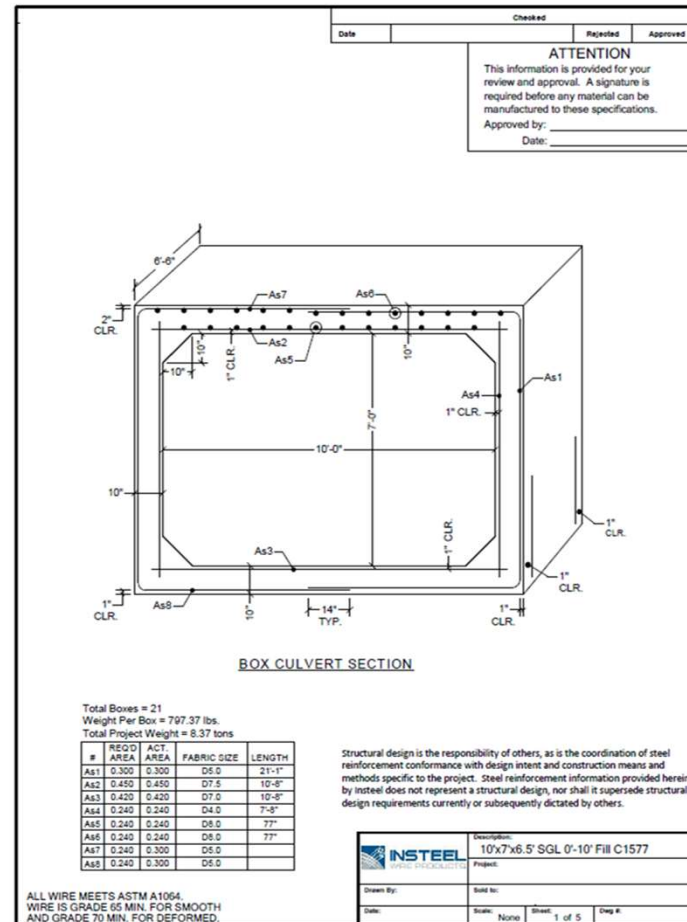



Upon award of work, the contractor is equipped with WWR information that is suitable for structural engineer evaluation as part of the finalized reinforced concrete culvert design contract documents, in turn facilitating a smooth approval process on through to production.





WWR Advantages

- Numerous mat combinations to suit precaster placement preference without compromising structural force profiles defined by engineer.

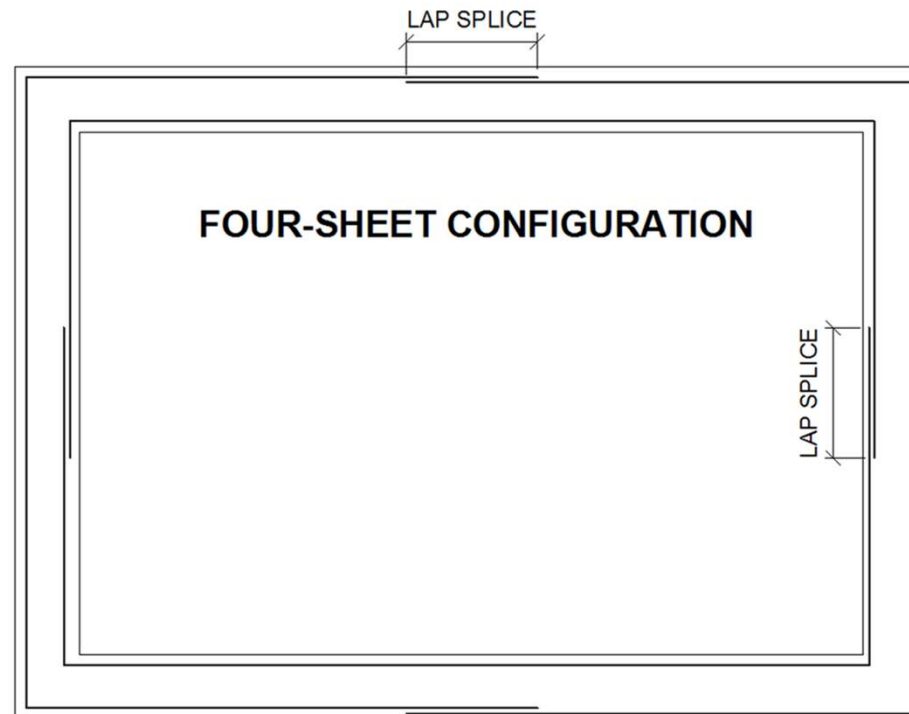



WWR Advantages

- Numerous mat combinations to suit precaster placement preference without compromising structural force profiles defined by engineer.

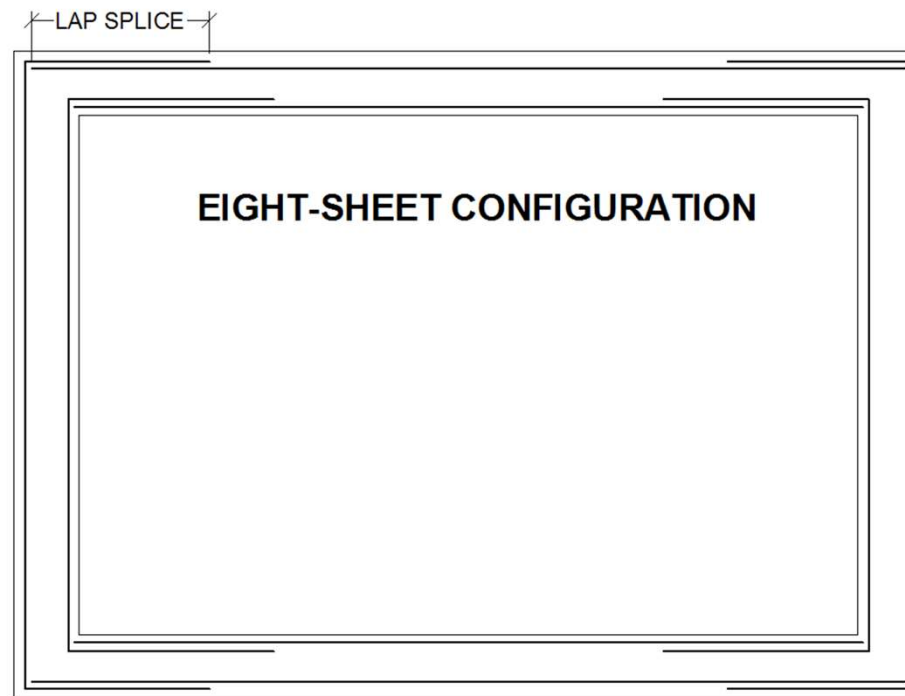



WWR Advantages

- Numerous mat combinations to suit precaster placement preference without compromising structural force profiles defined by engineer.

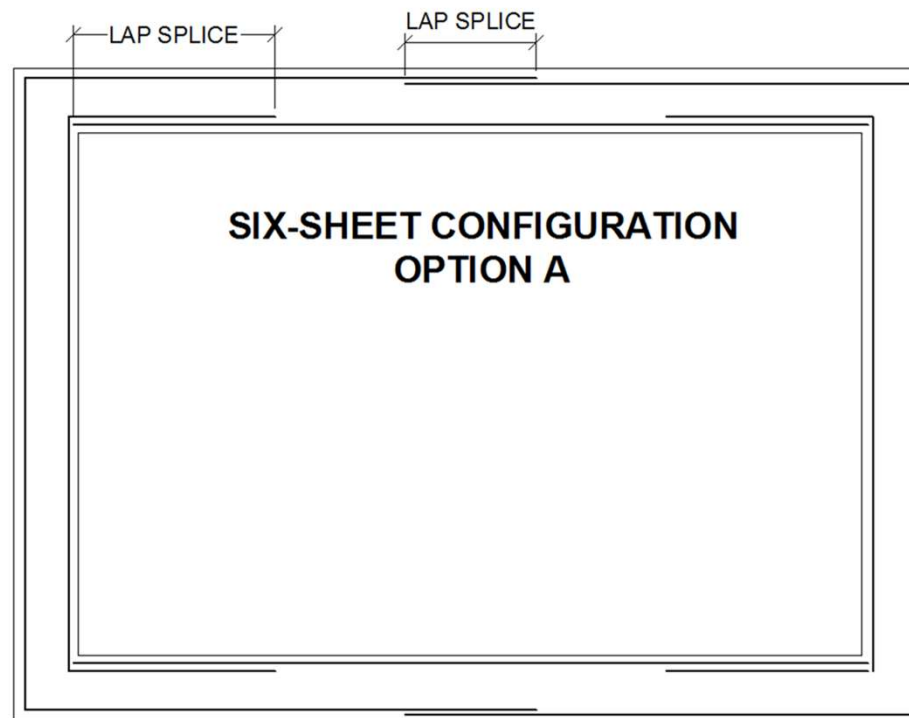



WWR Advantages

- Numerous mat combinations to suit precaster placement preference without compromising structural force profiles defined by engineer.

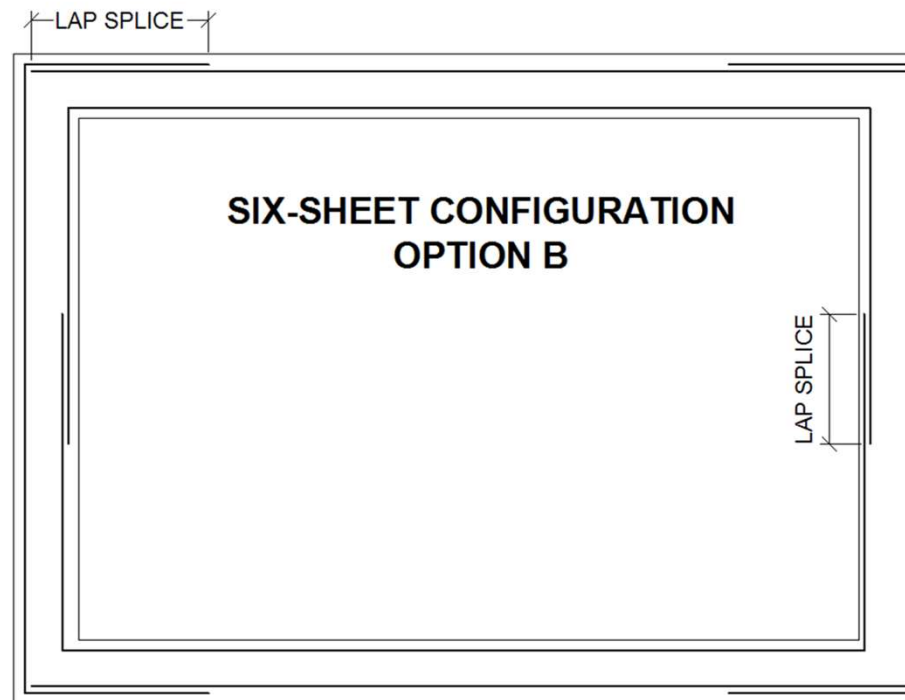



WWR Advantages

- Numerous mat combinations to suit precaster placement preference without compromising structural force profiles defined by engineer.

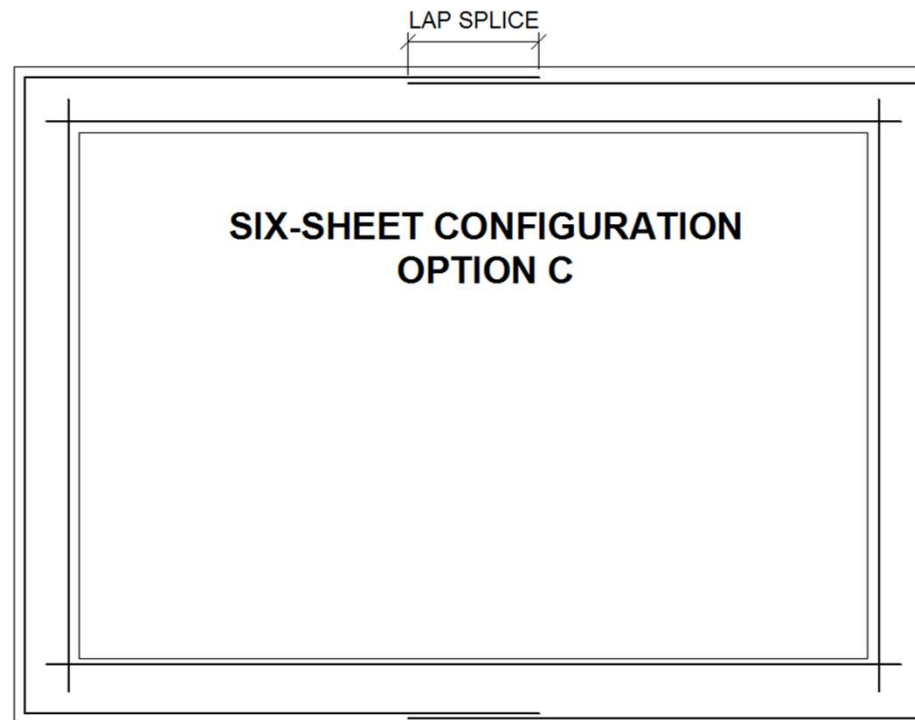



WWR Advantages

- Variable wire size and spacing are possible on a common mat, configured to minimize excessive reinforcement steel areas and accommodate unique lap splice or development requirements where applicable

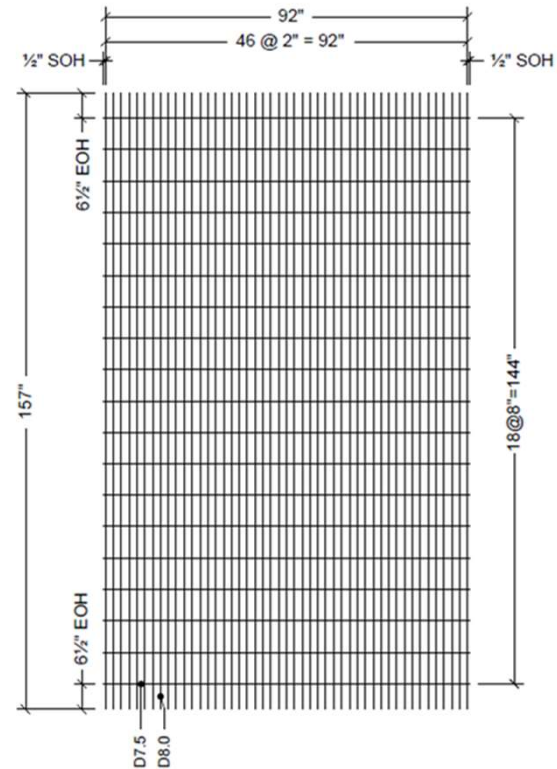



WWR Advantages

- Variable wire size and spacing are possible on a common mat, configured to minimize excessive reinforcement steel areas and accommodate unique lap splice or development requirements where applicable

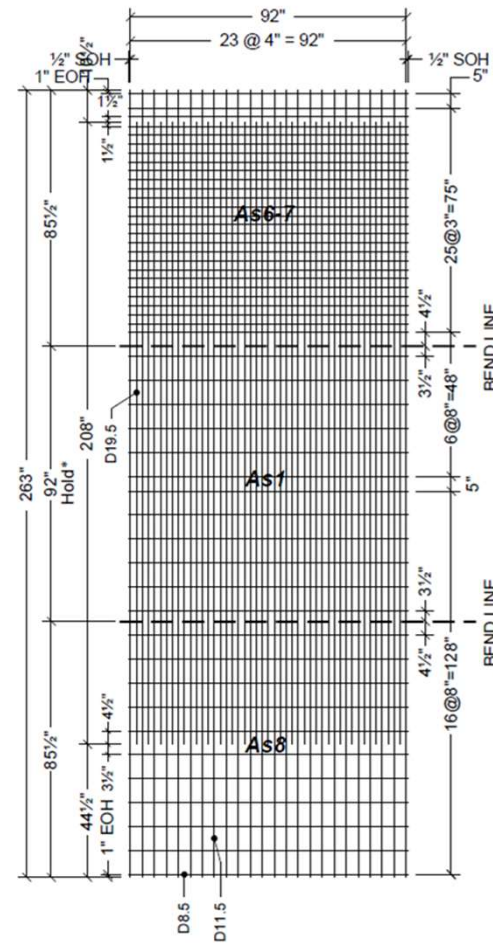



WWR Advantages

- Variable wire size and spacing are possible on a common mat, configured to minimize excessive reinforcement steel areas and accommodate unique lap splice or development requirements where applicable

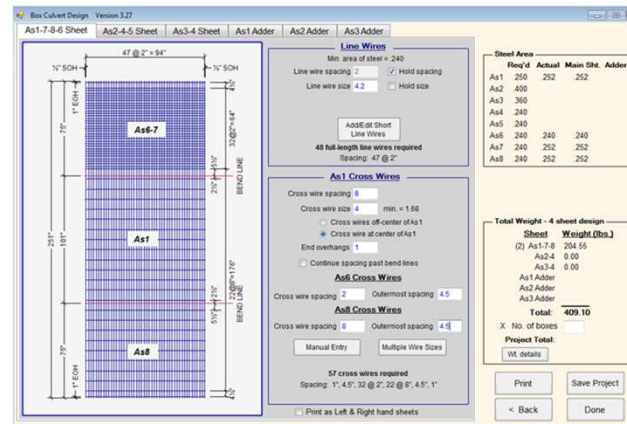
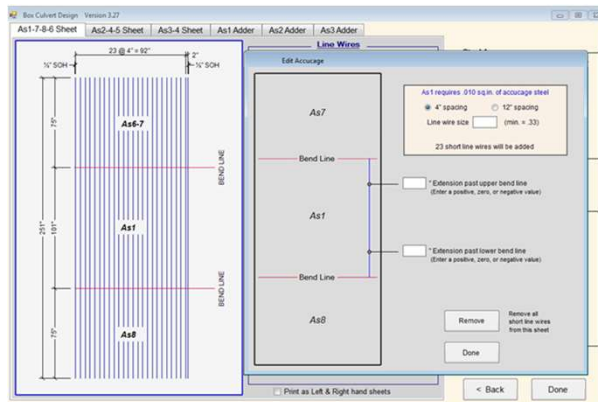
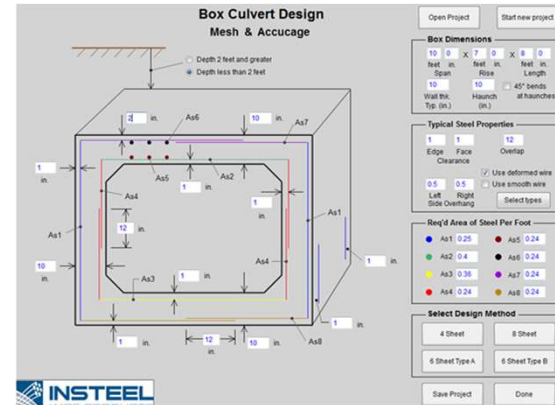



WWR Advantages

- WWR mats – bent or flat – hold shape and inherently maintain tolerances through controlled manufacture, simplifying placement and inspection operations at the precasting plant.





WWR Advantages

- Material is cold-worked (through drawing or rolling), and therefore inherently achieves a higher yield strength than hot-rolled material direct from billets.
- High yield strength can be taken advantage of during structural design, reducing steel weight. Yield strengths of 80 ksi commonly achieved and specified; design to 75 ksi limit in AASHTO is a possibility without concerns over material availability and added cost.

